

Tender Details		10-06-2026 04:43:55
Tender Code	MMD/T-HTM1-03/0626	
Tender Type	Procurement Tender	
Type Of Bid	Two Bid	
Description	Procurement of 11/0.433 kV and 22/0.433 kV 630 KVA Three Phase, Copper Wound, CRGO Core, ONAN, Indoor Distribution Transformer EEL- II (STAR-II).	
Estimated Cost (In Lakhs)	6108	
Basis of prices	Firm Price Basis	
Tender Validity	120	
Delivery Requirement (In Months)	9	
Tender on rate contract basis	NO	
Tender Fee (In INR)	10000	
GST In INR (@18% on Tender Fee: SAC No.	1800	
Total Tender Fee Amount including GST in INR.	11800	
Contact	Kirankumar Shinde , 7045791361 ,cemmcmsedcl@gmail.com	
Pre-Qualifying Req	As per Tender terms and conditions	
Budget Type	NA	
Scheme Code	null	
Scheme Name		
Department	Material Management Cell	
Office Type	HO	
Location Type	Corporate Office	
Designation	Executive Engineer(Distribution)	
Pre-Bid Meeting Address	THE CHIEF ENGINEER Maharashtra State Electricity Distribution Co. Ltd. Material Management Department, Plot No. G-9, "Prakashgad" First floor, Prof. A. K. Marg, Bandra(E), Mumbai-400051	
Bid Opening Address	THE CHIEF ENGINEER Maharashtra State Electricity Distribution Co. Ltd. Material Management Department, Plot No. G-9, "Prakashgad" First floor, Prof. A. K. Marg,Bandra(E), Mumbai-400051	
Version No	1	
Call for Deviation	YES	
Is Annexure C1 Applicable	YES	
Is Manufacturer Applicable	YES	
Is Trader Applicable	NO	
Minimum % of Offered Quantity	20	
Is Power Supplier Applicable	NO	
Tender Sale Start Date	10-06-2026 17:10	
Tender Sale End Date	01-07-2026 12:00	
Bid Start Date	10-06-2026 17:30	
Bid End Date	01-07-2026 15:00	
Pre-Bid Meeting Date	18-06-2026 16:00	
Techno-Commercial Bid opening on	01-07-2026 15:30	
Price Bid opening on	Will be declared later	
Annexure C1 Opening Date	Will be declared later	
Winner Selection Date	Will be declared later	
Can Bidder opt for EMD Exemption	YES	
Is Annexure-E [Consent for MSEDCL Standard Technical Specifications and GTP] Applicable ?	NO	



MATERIAL MANAGEMENT DEPARTMENT  
 MAHARASHTRA STATE ELECTRICITY DISTRIBUTION CO. LTD.  
 Tender No. MMD/T-HTM1-03/0626

## **TENDER BID NOTICE**

The Chief Engineer, Material Management Department (MMD), on behalf of Maharashtra State Electricity Distribution Company Limited (the Purchaser), hereby invites sealed bids from eligible bidders for procurement of 11/0.433 kV and 22/0.433 kV 630 KVA Three Phase, Copper Wound, CRGO Core, ONAN, Indoor Distribution Transformer EEL- II (STAR-II). Entire bidding document is available online on <https://etender.mahadiscom.in/eatApp/> as per date indicated below. Any changes in the Bid Schedule, corrigendum etc. shall also be notified via MSEDCL's website. Prospective bidders are therefore requested to regularly check the website for any updates.

**Tender No. MMD/T-HTM1-03/0626**

**Estimated Tender Cost: Rs. 61.08 Crore inclusive of 18% GST.**

**Tender Fee:** Rs. 25,000 + 18% GST

The bidder should submit non-refundable Bid Fee of Rs. 25,000 + 18% GST paid through online payment only, prior to the dead line for submission of bids as per the procedure laid by the MSEDCL.

**Earnest Money Deposit:** The bid must be accompanied with EMD @ 0.5% (Half Percent) of estimated cost of the offered item of the tender in the form of Demand Draft or BG in electronic form (e-BG) as per the Annexure-M enclosed with tender documents having validity of 120 days from opening of tender. Interest shall not be allowed on EMD.

The scanned copy of the online payment receipt / Demand Drafts / BG should be uploaded (in e-tendering) and the Demand Drafts/BGs should be submitted to this office on or before submission date and time.

Calendar of Events Event	Date and Time
Begin Sale of Bid Document	10.06.2026
Date and time of submission of Bids	01.07.2026 at 15:00 hrs.
Date and time of Bid Opening	01.07.2026 at 15:30 hrs.
Date and time of Pre bid meeting	18.06.2026 at 16:00 hrs. Google Meet joining info <a href="https://meet.google.com/qiv-diee-psf">https://meet.google.com/qiv-diee-psf</a>

**THE CHIEF ENGINEER**  
**Maharashtra State Electricity Distribution Co. Ltd.**  
**Material Management Department,**  
**Plot No. G-9, "Prakashgad" First floor, Prof. A. K. Marg,**  
**Bandra(E), Mumbai-400051.**  
**E-mail- cemmcsedcl@mahadiscom.in, cemmcsedcl@gmail.com**

**MAHARASHTRA STATE ELECTRICITY DISTRIBUTION CO. LTD.**

TENDER FOR

Procurement of 11/0.433 kV and 22/0.433 kV, 630 KVA Three  
Phase, Copper Wound, CRGO Core, ONAN, Indoor Distribution  
Transformer EEL- II ( STAR-II)

Tender No: MMD/T-HTM1-03/0626



**OFFICE OF THE CHIEF ENGINEER,  
Maharashtra State Electricity Distribution Co. Ltd.  
Material Management Department,  
Plot No. G-9, "Prakashgad" First floor, Prof. A. K. Marg,  
Bandra (E), Mumbai – 400 051.  
E-mail- cemmcsedcl@mahadiscom.in, cemmcsedcl@gmail.com**

## INDEX

SR. NO.	CLAUSE NO.	DESCRIPTION
1	-	BID NOTICE
2	-	SECTION I: INVITATION TO TENDER AND INSTRUCTION TO BIDDERS
3	I	SCOPE OF WORK
4	II	QUALIFYING REQUIREMENTS
5	III	PRICES
6	IV	TAXES
7	V	BASIS OF PRICES
8	VI	PRICE VARIATION
9	VII	DELIVERY
10	VIII	OFFERING THE MATERIAL
11	IX	CONFLICT OF INTEREST
12	X	QUOTATION
13	XI	AMBIGUITY IN QUOTATION
14	XII	FILLING IN OF ANNEXURE
15	XIII	ADDITIONS/ALTERATIONS PROHIBITED
16	XIV	BIS LICENSE AND BEE CERTIFICATE
17	XV	MANDATORY REQUIREMENT OF SUBMISSION OF OFFER
18	XVI	SUBMISSION OF DRAWING & BILL OF MATERIAL
19	XVII	NAME OF AUTHORIZED REPRESENTATIVE
20	XVIII (A)	OFFER OF MICRO & SMALL ENTERPRISES
21	XVIII (B)	PREFERENCE TO INDUSTRIAL UNITS LOCATED IN MAHARASHTRA AND OFFERS BY MATCHING RATES WITH LOWEST ACCEPTABLE BIDDER
22	XVIII (C)	MATCHING OF RATES
23	XIX	QUANTITY ALLOCATION
24	XX	EARNEST MONEY DEPOSIT (EMD)
25	XXI	SIGNING OF THE TENDER DOCUMENTS
26	XXII	SUBMISSION / SUPERSCRIBING OF THE TENDER DOCUMENTS
27	XXIII	TIMELY SUBMISSION OF OFFER
28	XXIV	PURCHASER'S RIGHT
29	XXV	DISREGARD OF TENDER CONDITIONS
30	XXVI	PROHIBITION FOR POST TENDER CORRESPONDENCE
31	XXVII	RIGHT TO ORDER OUT QUANTITY IN VARIANCE TO OFFERED QUANTITY
32	XXVIII	ACCEPTANCE OF TENDER
33	XXIX	NOTIFICATION OF AWARD
34	XXX	EARNEST MONEY OF UNSUCCESSFUL BIDDER
35	XXXI	VALIDITY OF OFFERS
36	XXXII	DECLARATION FROM BIDDER
37	XXXIII	CORRUPT OR FRAUDULENT PRACTICES
38	XXXIV	INFLUENCE
39	XXXV	TENDER FEES EXEMPTION
40	XXXVI	PRE-BID MEETING
41	XXXVII	CLARIFICATION ON DEVIATIONS
42	-	CERTIFICATE
43	-	<b>Section II: CONDITIONS OF SUPPLY</b>
44	1	EFFECT OF CONTRACT
45	2	QUALITY OF SUPPLIES

<b>SR. NO.</b>	<b>CLAUSE NO.</b>	<b>DESCRIPTION</b>
46	3	MATERIAL AND COMPONENTS
47	4	ACCEPTANCE OF SUPPLIES/INSPECTION
48	5	RIGHT TO CARRY OUT INSPECTION DURING MANUFACTURING
49	6	RIGHT TO REVISE DESPATCH INSTRUCTIONS, DELIVERY SCHEDULE AND TO DEFER SUPPLIES
50	7	WAGAN LOADS/TRUCK LOADS
51	8	ROAD TRANSPORT
52	9	DESPATCH INTIMATION
53	10	BILL OF MATERIALS
54	11	PACKING LIST
55	12	REPLACEMENT OF GOODS LOST, BROKEN OR DAMAGED
56	13	REPLACEMENT OF REJECTED MATERIALS
57	14	MATERIAL DESPATCHED AND PROGRAMME
58	15	MATERIAL RECEIPT & SUBMISSION OF BILLS AT CONSIGNEE
59	16	PAYMENT OF BILLS
60	17	TAXES
61	18	DEDUCTION
62	19	GUARANTEE
63	20	(I)LIFTING OF REJECTED/DAMAGED MATERIALS FROM STORES AND (II)LIFTING OF FAILED TRANSFORMERS FROM DIVISION FILTER UNIT
64	21	LIQUIDATED DAMAGES FOR LATE DELIVERY
65	22	ORDER PLACED ON TIME PREFERENCE BASIS (WHEREVER APPLICABLE)
66	23	FORCE MAJEURE CLAUSE
67	24	ACCEPTANCE OF LOWER FORD RATE OFFERED IN SUBSEQUENT TENDER
68	25	PERFORMANCE OF CONTRACT:
69	26	CONTRACT PERFORMANCE DEPOSIT
70	27	POWER OF ATTORNEY:
71	28	SETTLEMENT OF DISPUTE
72	29	JURISDICTION:
73	30	TERMINATION OF CONTRACT
74	31	DEBAR / BLACKLISTING OF MANUFACTURER
75	32	TAX DEDUCTED AT SOURCE
76		<b>Section III:</b>
77	I	QUANTITY PROCUREMENT
78	II	QUALIFYING REQUIREMENT
79		<b>Formats:</b>
80	-	ANNEXURE B- QUANTITY, PRICE AND DELIVERY PERIOD
81	-	<u>ANNEXURE C-1 : MATCHING RATE</u>
82	-	<u>ANNEXURE - D : TECHNICAL SPECIFICATION</u>
83		ANNEXURE - E : CONSENT FOR PARTICIPATION IN TENDER AS NEW SUPPLIER
84		ANNEXURE - F : LEGAL LITIGATION UNDERTAKING BY BIDDER
85	-	ANNEXURE - G :PRICE VARIATION
86	-	ANNEXURE - H :GUARANTEED TECHNICAL PARTICULAR
87		ANNEXURE - I: DECLARATION FORMAT.
88	-	ANNEXURE - J : DISPATCH INSTRUCTIONS
89	-	ANNEXURE - K : LIST OF STORES
90		ANNEXURE - L : INSPECTION CALL FORMAT
91	-	ANNEXURE - M : BANK GUARANTEE FORMAT FOR EMD
92	-	ANNEXURE - N : BANK GUARANTEE FORMAT FOR CONTRACT PERFORMANCE DEPOSIT

=====

<b>SR. NO.</b>	<b>CLAUSE NO.</b>	<b>DESCRIPTION</b>
93	-	SCHEDULE- C
94		FORMAT-1 : ANNEXURE – U-I - INDEMNITY BOND
95		FORMAT-2 : UNDERTAKING FOR NOT APPROACHED ANY ONE FOR UNDUE INFLUENCE
96		FORMAT-3 : CERTIFICATE FROM CHARTERED ACCOUNTANT FOR NOT HAVE CONTROLLING STACK IN MORE THAN ONE ENTITY APPLIED FOR THE TENDER / BID
97		FORMAT-4 : CERTIFICATE FROM CHARTERED ACCOUNTANT FOR AVERAGE ANNUAL TURNOVER
98		FORMAT-5 : CERTIFICATE FOR NO DEVIATION

## SECTION-I

INVITATION TO TENDER AND INSTRUCTION TO BIDDERS

TENDER FORM (NOT TRANSFERABLE)

(TO BE SUBMITTED ONLINE DULY FILLED IN AND DIGITALLY SIGNED)

To be submitted online not later than the date mentioned in the tender details. For participating in tender opening, the bidder can login at the specified time and date of opening of the tender, if he desires so.

The bidder is requested to quote his lowest rates F.O.R. destination for the supply of materials. The material is required at various places in the State of Maharashtra. The tender documents duly filled-in and digitally signed, are to be submitted online before due time & date of the submission of tender in prescribed form.

The modifications made to the terms & conditions shall applicable to this tender only.

FOR CHIEF ENGINEER (M.M.DEPARTMENT)

## =====

## INSTRUCTIONS TO THE BIDDERS

**I SCOPE OF WORK:**

The scope of work under this tender is for design, engineering (wherever applicable), manufacture, inspection & testing before dispatch, packing and supply of material / equipment as specified in Annexure-D (Technical Specifications) at various destination sites / stores centers of the purchaser in Maharashtra.

The actual quantity that will be procured may vary depending upon the site requirement. The quantity advertised against various capacities can undergo change.

The list of various destination sites / stores centers of the purchaser is enclosed as Annexure K.

**II Qualifying Requirements:**

Qualifying requirement will be as per Section-III.

**III PRICES:**

(i) Prices are acceptable only on F.O.R. destination basis inclusive of Goods and Service Tax (GST for brevity) i.e. Integrated GST (IGST) for outside State / Central GST+ State GST (CGST+SGST) for within State, risk in transit, freight showing the break-up as desired in the Annexure 'B'. It shall be noted that quotations not conforming to F.O.R. destination basis inclusive of IGST/(CGST+SGST) etc. and to the unit as specified in Annexure 'B', shall be rejected even though the bidder's offer may be lowest. The bidder shall quote Ex-Works Price and element of freight and insurance along with applicable rate of IGST/(CGST+SGST). The F.O.R. destination price i.e. up to site or the Store Centre of the purchaser as the case may be inclusive of IGST/(CGST+SGST), risk in transit and freight will be programmatically calculated. While raising the invoices, however, IGST/(CGST+SGST) should be shown separately in the invoice raised.

(ii) For each of the items quoted, bidder shall specify offered quantity. However, the offered quantity shall not be less than 20% of the advertised quantity (Advertised quantity means the quantity required as indicated in Annexure 'B' / Price Bid) so as to deliver the said quantity within the delivery requirement of the Purchaser as indicated in the tender documents.

**IV TAXES:**

- (i) The Purchaser shall be registered under Goods and Service Tax Act and should comply with all the statutory compliance requirements of GST Law diligently.
- (ii) It is imperative for the bidder to indicate the amount of IGST/(CGST+SGST) included in their price while giving the break-up of F.O.R. destination price in Annexure 'B', failing which, the offer will be treated as ambiguous and will be rejected as per the provisions of clause X of tender form.
- (iii) After awarding the contract, the supplier shall not charge any additional amount towards GST; during the currency of contract except statutory variation by Central / State Government in normal (full) rate of integrated GST. In case the GST is decreased than the rate indicated in the price bid, the benefits of the

reduction in the GST shall be passed on to the purchaser. The increase in the GST rate due to increase in turnover during the contractual delivery period shall not be charged to the purchaser.

- (iv) Necessary documentary evidence for the GST claimed shall be submitted along with the bills.

**V BASIS OF PRICES:**

The bidder shall quote the prices on firm price basis, as has been specifically brought out in the Tender Details. For any deviation in this regard, the offer shall be summarily rejected.

**VI PRICE VARIATION:**

Not applicable.

**VII DELIVERY:**

- (i) Bidder is requested to quote delivery F.O.R. DESTINATION only & only in the unit of the item specified in Annexure 'B' i.e. if the quantity is in sets or in tones or in numbers or in kilometers or in coils, the rate of delivery shall only be in the same unit.
- (ii) It is mandatory on the part of the tenderer to quote the delivery on monthly basis. If the offered delivery is indicated on quarterly basis, then the delivery would be counted proportionately in three equal installments per month for liabilities of the contract including levy of liquidated damages.
- (iii) Size mix for the purpose of delivery, when delivery is quoted in assorted items, shall be determined by the Purchaser while issuing the A/T or dispatch instructions and will be binding on the bidder. The Purchaser will also have the liberty of modifying the size mix for the purpose of delivery, even after the A/T is issued.
- (iv) Offer shall be rejected if the commencement period and rate of delivery per month is not indicated.
- (v) The scheduled delivery period is 9 months from the letter of award will be as below;
- Commencement Period (CM): Min. 10% of offered quantity within 2 months.
- Completion Period (CP): Balance offered quantity in 7 or less months in equated lots.
- (vi) MSEDCL may issue dispatch instructions as per requirement. The quantity demanded per consignee may be less than or equal to monthly lot specified in contract. Wherever as per demand, if the quantity to be supplied to a consignee in a particular month is less than monthly lot quantity; the said quantity will be treated as lot quantity for the purpose of delivery and payment.
- (vii) MSEDCL may instruct the supplier to withhold entire or part of monthly supply of material for a specified period by giving two months advance instruction.
- (viii) Time being the essence of contract, the supplier shall strictly maintain monthly delivery schedule.

The bidder is advised to get their type tests & drawing approval immediately after placement of LoA from Chief Engineer (Testing & QC) so that the material is received by the purchaser well within the committed delivery period. If there is any delay in delivery of material as per schedule, the undelivered quantity as per schedule can be diverted to other good performing bidder.

#### **VIII OFFERING THE MATERIAL:**

- (A) The bidder shall offer the material as per MSEDCL technical specifications as per Annexure-D and shall have to fill the entire GTP.
- (B) The person / entity should not have controlling stake in more than one entity applied for the tender / bid. **Necessary certificate duly certified by Chartered Accountant to this effect shall be submitted along with the tender documents.**
- (C) Factory address, from which the bidder intends to supply the material against the tender, shall be as indicated in the latest approved online vendor registration form on e-tendering through which the vendor is submitting the offer.
- (D) The bidder shall offer the rates, taxes as applicable for the factory location indicated in his latest approved online vendor registration form on e-tendering through which he is submitting his offer.

#### **IX CONFLICT OF INTEREST**

A bidder may be considered to have a conflict of interest with one or more parties in a bidding process if they:

- (a) Have controlling shareholders in common; or
- (b) Receive or have received any director in direct subsidy from any of them; or
- (c) Have the same legal representative for purposes of a bid; or
- (d) Have a relationship with each other, directly or through common third parties, that puts the bidder in a position to have access to information about or influence on a bid of another bidder, or influence the decisions of the purchaser regarding the bidding process.

Bidders found to be in conflict of interest, shall be disqualified.

#### **X QUOTATION:**

- (i) Bidder shall quote his rate per unit specified in Annexure 'B' / Price Bid in figures.
- (ii) Bidder's printed terms and conditions will not be considered as forming part of the tender.

#### **XI AMBIGUITY IN QUOTATION:**

The bidder is requested to please make a note that in case of ambiguous terms in respect of offered quantity in Annexure- B and schedule 'C', F.O.R. condition, GST, basis of price (i.e. firm / variable) or if the blanks are left out in the offer, the item / tender shall be rejected.

#### **XII FILLING IN OF ANNEXURE:**

The bidder is requested to ensure that the comments against each and every item/clause of Annexure shall be clearly filled in and answered. Any item/clause shall not be left

blank or unanswered. If any item /clause is not applicable, the “Not Applicable (N.A.)” check box shall be selected.

**XIII ADDITIONS/ALTERATIONS PROHIBITED:**

The bidder shall not make any additions, alterations or changes in the Tender Form and the Conditions of Tender & Supply (Annexure ‘A’) including the description of material mentioned in Annexure ‘B’. They should quote rate for the material described or click the check box ‘Not quoted’ against each of the item in Annexure ‘B’/ Price Bid.

**XIV B.I.S. LICENCE AND BEE CERTIFICATE :**

A scanned copy of valid BIS License & BEE certifications for offered items ratings duly sealed & signed must be uploaded and submitted along with offer, failing which, the offer shall be rejected.

In case the validity of the BIS license / BEE certifications is expiring before date of submission of tender, necessary documentary proof of having applied for renewal of validity of the BIS license / BEE certifications must be uploaded while submitting the bid. The renewed copy of the BIS License / BEE certifications shall be submitted before commencement of supply.

However, valid BIS license / BEE certifications scan copy of offered material must be submitted by the qualifying bidders before commencement of supply, failing which their order will be cancelled with financial liability on supplier.

**XV MANDATORY REQUIREMENT OF SUBMISSION OF OFFER:**

The offer shall be submitted online duly filled in; attaching all the required documents, completed in all respects and should be digitally signed.

**XVI SUBMISSION OF DRAWING & BILL OF MATERIAL:**

The bidder shall submit the drawings and bill of material conforming to the tender specification wherever applicable. In such cases, the offer without the drawings and bill of material shall not be evaluated and considered. The drawings and bill of material submitted along with the bid shall not be considered for evaluation of the offer but the drawings and bill of material of the successful bidder shall be scrutinized when the Purchaser decides to accept such bid. It may, however, be noted that Purchaser’s action of evaluation of the tendered bid would not mean approval of the drawings and bill of material submitted along with the tender bid.

The bidder shall depute his authorized representative for discussion on the drawings, either immediately on hearing from the Purchaser or after receipt of Letter of Award. The formalities like submission of drawings, bill of material etc. and getting the same approved by the Purchaser shall be completed by the successful bidder within TEN DAYS from the date of Letter of Award of the contract. The approval to drawings complete in all respects mentioned in technical specifications (Annexure-D) will be accorded within SEVEN working days thereafter. Any delay in this regard shall lead to cancellation of the Letter of Award at the risk and cost of the bidder. The supplies against the contract shall conform to the approved detailed drawings / bill of material and the detailed technical specifications.

**XVII NAME OF AUTHORIZED REPRESENTATIVE:**

The digital certificate shall be in the name of person authorized by the firm. In case, the digital certificate is compromised or the person holding the digital certificate is no longer authorized to digitally sign the tender, it is the responsibility of the bidder to revoke this certificate and obtain the fresh certificate. While submitting the bids online only valid digital certificate shall be used. The vendors are requested to check the validity of digital signature and prior to the expiry date & they are requested to get their Digital signature key validated before expiry of the same. MSEDCL shall not be responsible for Non-submission of any of the Bids (Techno Commercial Bid, Deviation Bid, Price Bid, Annexure - C-1) by vendors due to expired/Invalid Digital signature.

The bidder is responsible for all the contractual liabilities and responsibilities thereof.

In case the bidder authorizes the representative to deal on behalf of the bidder, the name and address of such person should be informed to the purchaser. The bidder shall submit the power of Attorney in favour of representative duly executed before the Notary. In the absence of the Power of Attorney, the purchaser shall not deal with the representative.

**XVIII (A) Offer of Micro & Small Enterprises: (If matching is called)**

The bidder registered with Directorate of Industries of Government of Maharashtra for manufacturing the items tendered/offered and those who have attached valid certificate at the time of vendor registration shall be considered for concessions applicable and procurement of reserved items as per GoM G. R. dtd. 30-10-2015 amended up to date. These benefits shall be available only to those items approved during the registration process and subsequent updates in registration up to the submission of this tender.

Based on concession of Central Government's Micro & Small Enterprises office order dtd. 23-03-2012, 241 items are being kept reserved. As per above reservation of items 100% reserved items to be purchased from Micro & Small Enterprises out of which 20% reserved items to be purchased from S.C./S.T. enterprises. Reservation is applicable for a limited period unless & until re-examined. If Micro & Small Enterprises participated in the tender and the tendered item is not reserved, then 20% order with L-1 rate to be given to Micro & Small Enterprises and out of this 20%, 4% to be given to S.C./S.T. enterprises.

If there are any specific Government Directives such as reservation of items for units in Maharashtra, non-eligibility of preference to SSI units etc. for particular items, price and purchase preference etc. the same would be applicable irrespective of the fact that it has not been specifically incorporated in the tender notice and/or tender documents.

**(B) PREFERENCE TO INDUSTRIAL UNITS LOCATED IN MAHARASHTRA AND OFFERS BY MATCHING RATES WITH LOWEST ACCEPTABLE BIDDER**

The lowest acceptable rate will be the unit rate worked out without considering IGST/(CGST+SGST) as applicable and the same rate will be considered as applicable to the respective bidder who has agreed to accept order at lowest acceptable rate.

**(C) Matching of rates:**

The confirmation for acceptance of the order at the lowest acceptable rate indicated as above shall be given in the format as per Annexure 'C-1' of the tender documents. The same should be submitted online on or before the due time and date of submission of Annexure 'C-1'. The confirmation shall be opened online on due time and date of opening of Annexure 'C-1'. Schedule for submission and opening of Annexure 'C-1' shall be communicated separately by e-mail and on the website. Though confirmation in Annexure 'C-1' as above is called from all the qualified bidders, the bidders, who quoted rates within the range of 5% in comparison with the lowest acceptable rates, shall only be considered and their Annexure 'C-1' will be opened on the date and time intimated subsequently in the presence of bidders who chose to be present. Provided, however, that the Annexure 'C-1' of the bidders, who have quoted above the range of 5% in comparison with the lowest acceptable rates, shall also be considered in case the aforesaid bidders within the range of 5% are unable to fulfill the quantity requirement. In that case also, the date of opening of Annexure 'C-1' will be intimated to the bidders

- 1) In the above confirmation, if the bidder indicates any rate, then the confirmation given by the bidder will not be considered as valid.
- 2) The prices indicated in the original offer shall not be considered as valid once offer for acceptance of order by matching rates is given. In the event of withdrawal of offer by matching rates within the validity period, the entire offer against the tender shall become invalid and shall be summarily rejected and the earnest money paid by the bidder shall be forfeited.
- 3) The lowest acceptable rate is known only on the date of decision by the Competent Authority, hence the lowest acceptable rates of the tender cannot be declared in advance, however lowest acceptable rate of the tender would be equal to or more than the lowest rate received in the tender.

**XIX QUANTITY ALLOCATION:**

- 1) If L-1 bidder is within Maharashtra State and if total tender quantity for quoted item is offered by L-1 then 100% quantity will be awarded to L-1 bidder for quoted item.
- 2) If L-1 bidder is within Maharashtra State and offered quantity is less than the tender quantity for quoted item then,
  - a) Quantity allotted to L-1 bidder will be equal to quantity offered by him.
  - b) Balance quantity after allotment as (a) above, will be distributed among Maharashtra State bidders as per their price ranking (if ready to match with L-1 rate) subject to maximum 50% of total tender quantity for quoted item to Maharashtra State bidders including L-1 bidder.
  - c) Any balance quantity after allotment as (a) & (b) above, will be distributed as per their price ranking (if ready to match with L-1 rate) irrespective of bidder is Maharashtra or out of Maharashtra state bidder including partial allotment if any to Maharashtra bidder in (b) above.
- 3) If L-1 bidder is outside Maharashtra State then,

- =====
- a) If the L-1 bidder offered more than 50% of tendered quantity for quoted item then maximum of 50% of tender quantity for quoted item will be allotted to L-1 bidder.
  - b) If the L-1 bidder offered less than 50% of tendered quantity for quoted item then quantity equal to offered quantity for quoted item will be allotted to L-1 bidder.
  - c) Balance quantity after allotment as (a) or (b) above, will be distributed among Maharashtra State bidders as per their price ranking for 50% of required quantity (if ready to match with L-1 rate).
  - d) Any balance quantity after allotment as (a), (b) & (c) above, will be distributed as per their price ranking (if ready to match with L-1 rate) irrespective of bidder is Maharashtra or out of Maharashtra state bidder including partial allotment if any.
  - e) If all bidders including L-1 bidder are from outside Maharashtra state and if the offered quantity of L-1 bidder is 100 % then entire quantity will be allotted to L-1 bidder. If quantity offered by L-1 bidder is less than 100 %, then after allotting to L-1 bidder balance quantity will be allocated to remaining bidder who matched the L-1 rates as per price ranking & quantity quoted.
  - f) In spite of above the quantity allocation will be at the sole discretion of MSEDCL.
- 4) If new suppliers are allowed then maximum 20% of tender quantity will be reserved for new supplier as per their price ranking.

**XX EARNEST MONEY DEPOSIT (EMD):**

The bidder should pay the Earnest Money @ 0.5% (Half Percent) value of the estimated cost of offered item of the tender in the form of Demand Draft or Bank Guarantee in electronic form (e-BG) as per the Annexure-M enclosed with tender documents having validity of 120 days from opening of tender. Interest shall not be allowed on EMD. EMD shall be forfeited (i) in case the bidder withdraws the tender / offer during the validity period (ii) in case the bidder fails to pay the performance deposit if the contract is awarded.

However, bidders from the following categories are exempted from payment of earnest money deposit.

- 1) All Government and semi Government institutions under Govt. of Maharashtra and Zilla Parishad in Maharashtra and fully owned undertaking of any State Govt. and Govt. of India only for the items manufactured by such institutions.
- 2) Micro and Small Enterprises registered under Micro, Small and Medium Enterprises Development Act-2006 only for the items mentioned in their permanent registration certificate at the time of vendor registration.
- 3) The bidder registered with N.S.I.C. and those who have attached valid N.S.I.C. Registration Certificate for the items mentioned in their permanent registration certificate at the time of vendor registration.

The benefits mentioned in (1) to (3) above shall be available only to those items approved during the registration process and subsequent updates in registration up to the date of submission of this tender.

Exempted bidders should upload a latest valid certificate issued by any approved body of 'Ministry of Small & Medium Enterprises' (MSME) such as 'National Small Industries Corporation' (NSIC) or 'Udyam registration' for EMD exemption.

**XXI SIGNING OF THE TENDER DOCUMENTS:**

Offer shall be submitted along with the tender documents and duly filled in with all Sections / Annexures / Appendixes / Schedules etc. The offer shall be signed with valid digital signature.

**XXII SUBMISSION / SUPERSCRIBING OF THE TENDER DOCUMENTS:**

The offer is to be submitted as follows.

**(a) Online Submission:**

- (i) Techno-Commercial Bid (Part-I): This part shall contain all technical and commercial aspects of the bid and documents supporting the same except the Price Bid.

**The bidder is requested to please make a note that in case of the Price Bid (Part-II) is submitted instead of Techno-Commercial Bid in Part-I or submitted Price Bid (Part-II) along with Techno-Commercial Bid in Part-I, the offer shall be rejected.**

- (ii) Price Bid (Part-II)

This part shall contain only the Price Bid strictly in the prescribed format, i.e. Annexure 'B'.

**(b) Off line Submission:**

Physical submission of documents (Part-III) – Not mandatory.

Envelope for this part shall contain documents like Type Test Reports, Drawings, Bill of Material, Catalogues etc. wherever applicable as per technical specification and they shall be scanned and these scanned documents to be taken into PDF format on CD media (2 sets) and are to be submitted to Executive Engineer (HTM-1) in the office of Chief Engineer, Material Management Department in sealed envelope on or before due date & time of submission.

**METHOD OF SUBMISSION OF PART-III AND THEIR OPENING:**

This envelope shall be individually sealed and shall be superscribed with the name and address of bidders and the following information before posting or delivering the same:

- i. Tender No.
- ii. Due date and time of submission.
- iii. Due date and time of opening.

Envelope as above shall be submitted on or before the prescribed due date and time of submission and shall be opened on due date and time of opening as prescribed.

In case of bidders whose techno-commercial bid is acceptable, their Price Bids will be opened at a later date. This date shall be intimated to such bidders separately.

**XXIII TIMELY SUBMISSION OF OFFER:**

- (a) The bid is to be submitted online on or before due date and time of submission to the Purchaser at website.
- (b) It is advisable to submit the digitally signed offer sufficiently in advance of due date and time so as to avoid last minute congestion of network / server.
- (c) Offer received after the due date and time of submission shall not be accepted.
- (d) In case, the due date of opening of tender happens to be holiday, the offer shall be opened on the next working day at the same time.

**XXIV PURCHASERS RIGHT:**

The Purchaser reserves the right to reject any offer without assigning any reason whatsoever.

The Purchaser reserves the right to make any changes in terms & condition at any stage of the process without assigning any reason whatsoever.

If any type of legal litigation against MSEDCL is pending in any court/Forum against/by the bidder or its sister concern/Director/Partner/Proprietor, then purchaser reserves the right to reject partly or fully their bid without assigning any reasons thereof.

Bidder has to submit the declaration as per Annexure-F regarding no any type of legal litigation against MSEDCL is pending in any court/Forum against/by the bidder or its sister concern/Director/Partner/Proprietor.

**XXV DISREGARD OF TENDER CONDITIONS:**

Tender containing any deviations / additions / alterations / changes in the conditions of the tender and supply as stated in Annexure 'A', 'B', 'C-I', 'D', 'E' and schedule 'C' shall not be acceptable.

The bidder having digitally signed all the tender documents indicates any deviations / additions / alterations / changes in the covering letter, unrelated annexure and schedules of the offer or elsewhere, the same shall be ignored and the offer shall be treated as meeting with all specified tender conditions.

**XXVI PROHIBITION FOR POST TENDER CORRESPONDENCE:**

The Bidder should note that no correspondence shall be entertained or considered after the due date and time of submission of tender unless otherwise sought by the Purchaser.

The Bidder should also note that no correspondence shall be entertained or considered after the placement of LoA/AT unless otherwise sought by the Purchaser.

**XXVII RIGHT TO ORDER OUT QUANTITY IN VARIANCE TO OFFERED QUANTITY:**

The Purchaser reserves the right to order out / procure any quantity in excess of the offered quantity with change in delivery period with mutual consent. The quantity specified may be for dispatch to one destination or several places.

**XXVIII ACCEPTANCE OF TENDER:**

The Purchaser does not bind itself to accept the lowest or any tender; neither will any reasons be assigned for the rejection of any tender or part of tender. It is also not binding on the Purchaser to disclose any analysis report on tender/samples. The bidder on his part binds himself to supply any item or items selected from his offer in part or whole at the option of the Purchaser.

**XXIX NOTIFICATION OF AWARD:**

Notification of Award of contract will be made by a letter of Award, to be sent by registered post or given by hand or by E-mail to the successful bidder by the Purchaser. It could also be made by e-mail ~~or by Fax~~ to be confirmed in writing by registered post to the successful bidder by the Purchaser.

**XXX EARNEST MONEY OF UNSUCCESSFUL BIDDER:**

Earnest money deposit will be returned to the unsuccessful bidder by RTGS within 7 (seven) working days after the tender has been decided and on submission of receipt of E.M.D. payment to the G.M. (F&A-SB), MSEDCL, Prakashgad, Prof. A.K. Marg, Bandra (East), Mumbai-400051. Earnest money deposit in the form of BG in electronic form (e-BG) will be returned to the unsuccessful bidder within 7 (seven) working days by Chief Engineer, Material Management Department after the tender has been decided.

**XXXI VALIDITY OF OFFERS:**

The bidder shall keep the offer valid for acceptance up to and including last date of calendar month, covering the date of completion of 120 days (one hundred and Twenty days) from the date of opening of the tender and shall also agree to extend the period of validity required by the Purchaser. The bidder shall not be allowed to modify or change the conditions of the tender while extending the period of validity.

**XXXII DECLARATION FROM BIDDER:**

In order to ensure participation of reliable and honest bidders / contractors / vendors, etc. the bidder shall submit the declaration along with the bid in Annexure-I.

**XXXIII CORRUPT OR FRAUDULENT PRACTICES:**

The Maharashtra State Electricity Distribution Company Ltd. and the State require that bidders / suppliers / contractors observe the highest standard of ethics during the procurement and execution of such contracts. In pursuance of this policy, MSEDCL:

(a) defines for the purposes of this provision, the terms set forth below as follows:

- (i) "corrupt practice" means behavior on the part of officials in the public or private sectors by which they improperly and unlawfully enrich themselves and / or those close to them, or induce others to do so, by misusing the position in which they are placed, and it includes the offering, giving, receiving or soliciting of anything of value to influence the action of any such official in the procurement process or in contract execution; and
- (ii) "fraudulent practice" means a misrepresentation of facts in order to influence a procurement process or the execution of a contract to the detriment of the Employer, and includes collusive practice among bidders (prior to or after

bid submission) designed to establish bid prices at artificial non-competitive levels and to deprive the Employer of the benefits of free and open competition.

- (b) will reject a proposal for award if it determines that the bidder recommended for award has engaged in corrupt or fraudulent practices in competing for the contract in question;
- (c) will declare a firm ineligible, either indefinitely or for a stated period of time, to be awarded an MSEDCL contract if at any time it determines that the firm has engaged in corrupt or fraudulent practices in competing for, or in executing, an MSEDCL contract.

#### **XXXIV INFLUENCE:**

Any efforts by the bidders to influence the owner during evaluation process before order placement will be rejected. Similarly deviation in the term of payments, penalty, performance deposit, delivery period will be treated as non-responsive quotation/offer and will not be considered for evaluation/order placement.

Bidder shall submit the undertaking certifying that they have not approached any one for undue influence.

#### **XXXV TENDER FEES EXEMPTION:**

Tender fee to be paid at the time of uploading / online submission of the tender. Bidders from the following categories are exempted from payment of Tender fees:

- 1) All Government and semi Government institutions under Govt. of Maharashtra and Zilla Parishad in Maharashtra and fully owned undertaking of any State Govt. and Govt. of India only for the items manufactured by such institutions.
- 2) Micro and Small Enterprises registered under Micro, Small and Medium Enterprises Development Act-2006 only for the items mentioned in their permanent registration certificate at the time of vendor registration.
- 3) The bidder registered with N.S.I.C. and those who have attached valid N.S.I.C. Registration Certificate at the time of vendor registration.

The benefits mentioned in (1) to (3) above shall be available only to those items approved during the registration process and subsequent updates in registration up to the date of submission of this tender.

The tender fee paid against the particular tender shall not be refunded / transferred /adjusted at all.

#### **XXXVI PRE-BID MEETING:**

- 1) The bidder or its official representative is invited to attend pre-bid meeting (s) which will take place at the place, date and time designated in the Bidding Data.
- 2) The purpose of the pre-bid meeting(s) will be to present the salient features of the bidding documents to the bidders, including the bid submittal requirements, the Conditions of Contract (including payment terms and conditions), the technical features of the project, and to clarify issues and to answer questions on any matter that may be raised by the bidders.
- 3) The bidder is advised to visit the Site and study the bid document thoroughly, and is requested to submit any questions in writing or by E-mail, to reach the Employer not later than one week before the pre-bid meeting.

- 4) Minutes of the meetings, including the text of the questions raised and the responses given will be transmitted without delay to all the prospective bidders through the website <https://etender.mahadiscom.in/eatApp/>. Any modification of the bidding documents listed which may become necessary as a result of the pre-bid meetings shall be made by the Purchaser exclusively through the issue of an Addendum pursuant to Clause and not through the minutes of the pre-bid meetings.
- 5) Non attendance at the pre-bid meeting will not be a cause for disqualification of a bidder. Nevertheless, senior representatives of the bidders are strongly encouraged to participate in the pre-bid meeting to help ensure that they fully understand the key concerns of the Employer and the Employer's requirements.

**XXXVII CLARIFICATION ON DEVIATIONS:**

The purchaser, if necessary, shall obtain clarifications on deviations within 1 or 2 working days by requesting for such information from any or all the bidders in writing, as may be necessary.

The same should be submitted online on or before the due time and date of submission of Deviation Bid. The clarification shall be opened online on due time and date of opening of Deviation Bid.

The Schedule for submission and opening of Deviation Bid shall be communicated by auto generated e-mail of the e-tender website.

**CERTIFICATE:**

I / We agree to supply the materials at the rates herein tendered by me / us subject to the conditions of tender and supply in Annexure 'A' of this tender which I / We have carefully read and which I / we have thoroughly understood and to which I / we agree. I / we hereby agree to keep this offer open up to the date mentioned in tender details and shall be bound by communication of acceptance dispatched within the validity period.

Seal & Signature of bidder



## SECTION-II

### Annexure "A"

#### CONDITIONS OF SUPPLY

##### 1) EFFECT OF CONTRACT:

The contract shall be considered as having come in to force and shall be in operation for a period of 9 months from the date of Notification of Award. The bidder whose offer is accepted is hereinafter called "the supplier".

##### 2) QUALITY OF SUPPLIES:

All materials supplied shall be strictly as per specification laid down by MSEDCL and in accordance with the approved standard Guaranteed Technical Particulars (GTP), drawings and type test reports.

##### 3) MATERIAL AND COMPONENTS:

The material and components not specifically stated in this specification but which are necessary for satisfactory operation of the equipment / items specified, shall be deemed to be included unless specifically excluded and shall be supplied without any extra cost.

##### 4) ACCEPTANCE OF SUPPLIES / INSPECTION:

- i) The supplier shall normally offer at a time, the entire quantity required to be delivered every month as per the delivery schedule indicated at Annexure 'B' of A/T for the purpose of inspection by the Purchaser.

Time being the essence of contract; the supplier shall strictly maintain the monthly delivery schedule.

- ii) Materials shall be inspected by the Purchaser's Executive Engineer / or the representative authorized by the Purchaser before dispatch. An intimation in the prescribed Proforma about the date on which materials shall be ready for inspection, indicating quantity, shall have to be given to the Executive Engineer / or the representative authorized by the Purchaser before dispatch so as to reach him 10 working days in advance, failing which, the supplier shall be responsible for delay in delivery on account of inspection.

The intimation in the prescribed proforma (Inspection call) shall be forwarded on MSEDCL Material Inspection Portal i.e. <https://mip.mahadiscom.in/InspectionPortal/>. Inspection calls sent via any other media will not be entertained and the supplier will be responsible for delay in delivery on account of inspection.

The inspection call should reach to MSEDCL maximum 7 days prior to date of readiness. On receipt of such intimation, the materials shall be inspected within 10 working days from the date of receipt of inspection call. The materials shall be dispatched only after inspection and approval of same by the Inspector. The inspection approval letter shall be valid for a period of 30 days from the date of issue of letter to enable the supplier pack the material and arrange transportation thereof so that material should be reached at the respective consignee within scheduled delivery period.

After this period of 30 days, the validity of this inspection approval letter will lapse. If the material is not reached within scheduled delivery period to respective consignees, the approval of purchaser is to be sought by the supplier for revalidation of inspection approval letter at the sole discretion of MSEDCL.

For quantity supplied beyond contractual delivery period, statutory variations is applicable only when the delayed delivery is attributed to MSEDCL.

- iii) The supplier shall notify the names of the consignees as per DI, to whom the inspected lot would be dispatched. The supplier shall get the copies of inspection approval letter together with witness certificate duly signed by the concerned Inspecting Officer and also mention reference or inspection approval letter on the challan / invoice, failing which any delay occurred in getting the S.R. Notes from the consignees would be solely to supplier's account. The inspection report shall be filled in online on the same day by the Inspector from the site on MSEDCL web portal after the inspection.
- iv) Factory address, from which the bidder has to supply the material, shall be as indicated in the latest approved on line vendor registration form on e-tendering through which the bidder has submitted the offer.
- v) The supplier shall offer inspection call intimation of readiness of material as per the monthly schedule only. In the event, during the inspection by the Purchaser's Inspecting Officer, if it is observed that the quantity actually offered for inspection is less than the quantity indicated for inspection in the inspection call, the Purchaser shall be entitled to recover from the supplier, the actual expenses incurred for arranging the inspection, and the supplier shall not dispute the amount to be recovered.
- vi) The supplier shall submit the test certificates / reports from any NABL approved laboratory or the laboratory of his own for the respective quantity of material, before dispatch. The material shall not be dispatched unless and until the test certificates are approved by the Purchaser.
- vii) All the necessary help shall be extended by the supplier to the authorized representative of the Purchaser to carry out testing of equipment / materials. Testing equipment's shall be arranged by the supplier.
- viii) MSEDCL may issue the dispatch instructions (DI) to deliver the ordered quantity to the bidders in Maharashtra within same districts of factory location of the supplier. However, it will not be binding on the MSEDCL; supplier has to deliver the material in other districts as per MSEDCL requirement. Further outside Maharashtra bidders have to deliver the material as per MSEDCL requirement to the designated consignee.
- ix) MSEDCL on its sole discretion may get material / equipment inspected and tested by third party NABL lab.

#### **5) RIGHT TO CARRY OUT INSPECTION DURING MANUFACTURING:**

The Purchaser at its option, will inspect the material ordered during its process of manufacturing including the inspection of raw materials and will request the supplier to carry out such tests as may be necessary to ensure proper quality of the material. The samples of components of the material shall be subject to quality check by the inspecting officer during manufacturing.

=====

**6) RIGHT TO REVISE DESPATCH INSTRUCTIONS, DELIVERY SCHEDULE AND TO DEFER SUPPLIES:**

- i) The Purchaser reserves its right to revise the dispatch instructions issued along with the order, at the time of giving final clearance for dispatch after inspection of the material. If such change in destination is not intimated at the time of inspection approval or waiver of inspection, the supplier shall dispatch the material as per the dispatch instruction in accordance with A/T. indicated by him in the inspection call letter.
- ii) The Purchaser reserves its right to change the delivery schedule of the contract either by reducing the monthly lot up to 60% of the agreed lot or by increasing the same up to 120% of the agreed lot with prior two months' notice and the Purchaser shall not be liable to pay any compensation/damages on account of such change in delivery schedule.
- iii) The Purchaser reserves its right to defer the balance supply to be received against the order by giving two months' notice for a maximum period of 6 months. In such an event, the delivery period for the deferred material shall be deemed to be extended proportionate to the period of deferment and the Purchaser shall not be liable to pay any compensation/damages on account of such deferment of deliveries.

**7) WAGON LOADS / TRUCK LOADS:**

Quantity to be dispatched to consignee should be minimum in two full truck loads and may be part load as per the Purchaser's requirements may not necessarily be in full wagon load / truck load and may be part load as per the Purchaser's requirement.

**8) ROAD TRANSPORT:**

In case the supplier prefers to dispatch the materials by road transport at his risk and cost and without any extra cost to the Purchaser, the materials shall be accepted only during office hours on working days. The supplier should ensure that the goods reach the stores in first half so as to arrange their unloading during office hours, failing which, the Purchaser shall not be liable for delay in unloading and for inconvenience caused to the transport contractor in the form of detention etc. Unloading at stores will be arranged by the consignee.

**9) DESPATCH INTIMATION:**

The supplier shall inform by e-mail to the consignee details of dispatch along with e-way bill receipt in hard & soft format giving RR / LR No., Wagon / Truck No., Type of wagon, craneable consignment or otherwise, total value of consignment, etc. to facilitate the consignee to arrange for clearance of goods on [cemmcmsedcl@mahadiscom.in](mailto:cemmcmsedcl@mahadiscom.in) or [cemmcmsedcl@gmail.com](mailto:cemmcmsedcl@gmail.com).

**10) BILL OF MATERIALS: (WHEREVER APPLICABLE)**

The supplier shall furnish bill of materials for each type of equipment / material offered which should be consistent with the drawing, specification and guaranteed technical particulars. The copies of the bill of materials should always be enclosed along with the bill submitted by the supplier for payment wherein he should specifically mention the materials / components dispatched out of the bill of materials, if the equipment is not sent in totality. Where the equipment / material to be supplied consist of more than one component, the supplier claiming payment for equipment / materials shall certify that all components of the equipment / material have been supplied in full for the quantity indicated in the invoice. Part payment shall not be allowed.

**11) PACKING LIST:**

Each package shall contain, in waterproof cover, the detailed list indicating the order reference, date, list of content and reference to the approved bill of materials. Each item contained in the package shall be described sufficiently to enable identification of the quantity, weight etc. There should not be any alteration in the packing list incorporated in the order, soft copy of the packing list should be sent to all the consignees and hard copy to G.M. (F&A-SB) should be enclosed with the bills along with other documents.

**12) REPLACEMENT OF GOODS LOST, BROKEN OR DAMAGED:**

Notwithstanding anything herein contained, the supplier undertakes to be responsible for the safe arrival of the materials in good condition and without any loss or damage at the final destination and until the same be actually delivered to and received by the Purchaser at its stores or other place of final destination and for this purpose, materials carried by railways or other carrier shall be deemed to be so carried at the risk of the supplier. In case of transit damage / shortages, the payment shall be made only for the quantity received in good and working condition and the consignee shall lodge claims with carriers and transfer the same to the supplier with all necessary documents for settlement of the same with carriers at the supplier's end. The transit damages / shortages / losses reported by the consignee shall be repaired / replaced by the supplier duly inspected, free of cost, within one month from the date of such intimation of breakages / shortages / losses without waiting for settlement of the claims from carrier or insurance co. etc.

However, rectification of minor defects at store locations are allowed for following minor defects only.

- i. Leakages.
- ii. Bushing replacement
- iii. LA replacement
- iv. Nut bolt tightening etc.

**13) REPLACEMENT OF REJECTED MATERIALS:**

If, on inspection at the final destination, the Purchaser discovers any loss in the materials supplied or that they are received in damaged condition or that in the opinion of the Purchaser, they are not of the contracted quality or specification, the Purchaser shall be entitled (notwithstanding that the property in the materials shall have passed on to the Purchaser) to refuse to accept or reject the materials altogether and claim damages or cancel the contract and buy its requirements from any of its suppliers stipulating earliest possible delivery and in accordance with its tender system against the supplier and recover the damages if any, from the supplier from any outstanding sums that may be due to the supplier from the Purchaser against this contract or against any of the contract entered into with the supplier, without prejudice to other rights and remedies available to it in law and reserving always to itself the right to forfeit the performance deposit placed by the supplier for the due fulfillment of the contract.

In case the stores / materials are found not in accordance with the prescribed specifications and / or the approved sample, the same will be rejected and the supplier shall replace the rejected stores / materials free of cost within one month from the date of intimation. The replacement of goods shall also have to be got inspected as per inspection clause. Further if the stores / equipment supplied becomes incomplete on account of either

rejection or short supply of its components, the complete cost of the stores / equipment shall be recovered from supplier's bills without notice.

#### 14) MATERIAL DESPATCHED AND PROGRAMME:

A statement as under indicating dispatches effected during every month shall be furnished to this office along with the programme of manufacturing / dispatches during the following two months. In the event of no dispatch, the statement shall contain nil information.

MONTHLY STATEMENT:

- I. Name of Supplier:
- II. Reporting Month:

Sr. No.	A/T No.	Material	Item No. as Per A/T	Consignee	RR / LR Delivery Challan No. With date	Date of Actual Receipt of Material	Qty. Dispatched Between 26 <sup>th</sup> of Preceding Month and 25 <sup>th</sup> of the Reporting month	Programme of supply during the next 2 months
1	2	3	4	5	6	7	8	9

Consolidated details of the above information shall be furnished to office of the Chief Engineer (M.M. Dept.) after completing the supplies of a particular order. The copy of this consolidated information shall invariably be forwarded to the respective consignees, failing which; security deposit paid against the contract shall not be released.

#### 15) MATERIAL RECEIPT & SUBMISSION OF BILLS AT CONSIGNEE:

On receipt of material at destination of consignee as per DI, Additional Executive Engineer (MM DEPT.) of respective store should ensure the receipt of material in good & healthy condition. While receiving the material, store in charge should ensure the receipt of material as per Dispatch Instructions issued by MM Dept. Further, the store in charge should ensure the receipt of original & scan copies of following documents:

- a) Tax invoice.
- b) Detailed packing list.
- c) Bill of Material.
- d) Delivery challan.
- e) E-way bill receipt.
- f) Dispatch document (RR/LR).

On confirmation & validity of above documents, store in charge will generate Provisional SR Note through ERP system immediately for receipt of material at stores thereof.

Where required by the Purchaser, the successful bidder must send the operation and maintenance manuals, test certificates, drawings etc. for the material ordered. These should be sent immediately after dispatch of material and a statement to that effect should be made in the invoice.

After successful RST of supplied each lot, store in charge will generate final SR note through ERP system immediately from receipt of RST report at stores.

## 16) PAYMENT OF BILLS:

### (a) Terms of payment:

- a. The Bidder shall be paid 100% payment within 60 days from the date of receipt of material in good condition, against Stores Receipt Notes (S.R. Notes) issued by the concerned consignee.
- b. However, in respect of only those entities which qualify for 45 days payment period under the Micro, Small and Medium Enterprises Development Act, 2006, 100% payment of the Contract price will be paid within 45 days from the date of receipt of material at Consignee Store in good condition, against Stores Receipt Notes (S.R. Notes) issued by the concerned consignee.
- c. In respect of Micro, Small and Medium Enterprises, best efforts will be made for payment within 45 days from date of submission of invoice along with requisite documents after the delivery of entire lot. However, no claim for interest will be entertained in case of delay in payment beyond 45 days. The Micro, Small and Medium Enterprises who are ready to accept this payment term may only quote. No dispute in this regard will be entertained. After completion of order, the claims of whatsoever nature lodged after 30 days from the last date of payment will not be entertained.
- d. The payment shall be effected by A/C payee cheques / RTGS. Following documents as required in terms of order, will have to be forwarded to the G.M. (F&A-SB), Maharashtra State Electricity Distribution Co. Ltd., Prakashgad, Station Road, Bandra (East), Mumbai - 400 051 along with bills in triplicate to facilitate payment with a copy to the Chief Engineer of respective Zone.
  - (i) Invoice (on the basis of rates accepted as per A/T) issued in accordance with the provisions of GST Invoice Rules.
  - (ii) Inspection and Test Certificate approval.
  - (iii) E Way Bill
  - (iv) Copy of Acceptance letter of Permanent Bank Guarantee / Security Deposit Certificate.
  - (v) Packing list.
  - (vi) Approved Bill of Material.
  - (vii) Certificate of having dispatched Operation & Maintenance Manual, copies of Test Certificates and approved drawings / Bill of Material to consignees wherever applicable.

The supplier shall forward the original R.R. / L.R. direct to the consignee along with relevant documents. The original bill shall be forwarded to The G.M. (F&A-SB), MSEDCL, Prakashgad, Bandra (E) and marked ORIGINAL. The bill should indicate the GST registration no. and date held by him under the GST Law. The Purchaser shall not be responsible for delay in payment of bills if the supplier fails to comply with any of the above requirements.

Supplier's copy of S.R. Note will be forwarded by the consignees through their

respective Common Stores for supplier's record towards acknowledgement of receipt of material. Accounts copy of S.R. Note will be forwarded by the respective Common Stores to G.M. (F&A-SB) for payment.

Wherever the payment is to be effected against Material Receipt Intimation (MRI) and if the supplier fails to forward the documents such as inspection report, bill of materials, approved drawings, etc. wherever required along with the invoice to the respective consignees and no payment shall be made against the said MRI.

The whole of the first lot as well as monthly lot when delivered in installments, the date of delivery and due date of payment will be counted after the receipt of the entire lot.

Any amount more than Rs. One Lakh can be transferred to the bank Account of the supplier electronically. For this RTGS (Real Time Gross Settlement) provision, following information is to be furnished by the bidder in the required documents of the online offer.

1. Name of the Company
2. Name of the Bank & Branch with address where the amount is to be transferred.
3. Current Account Number (15 digits)
4. RTGS No. / (IFSC Code ) ( Indian Financial Security Code)
5. MICR Code of the Bank
6. Company's email ID
7. Contact Name & Telephone No.

#### **17) TAXES:**

(A) Notwithstanding the fact that contract price is inclusive of GST:

(i) GST shall be paid at actual on the basis of due date of delivery or actual date of supply whichever is lower against documentary evidence.

(ii) Variation in GST on bought out items shall not be entertained.

(B) Structural changes in and due to 'Input Tax Credit' Scheme: -

(i) In the event of any structural change occurred in the Input Tax Credit Scheme after the date of submission of the tender till the currency of the contract, the benefit out of such change shall be passed on to the purchaser.

(ii) In the event of 'Input Tax Credit' being extended by the GST Law which were otherwise ineligible for claiming Input tax credit thereof, the seller should advise the purchaser about the additional benefits accrued or any variation thereof, through a letter containing such details and computation within such time as may be agreed between both the parties i.e. Supplier & MSEDCL.

#### **18) DEDUCTION:**

Any amount or amounts which become payable by the supplier to the purchaser under a particular contract, shall be deducted by the purchaser from any amount/amounts due or becoming due to the supplier under the same or any other contract and shall be adjusted against dues to the Purchaser.

**19) GUARANTEE:**

Material offered shall be guaranteed for a period 66 months from the date of receipt at the consignee's Stores Center or 60 months from the date of commissioning, whichever is earlier. In case of failure of material within the above guarantee period, tenderer shall make available other new conditioned / repaired material / equipment, free of cost at Division / Stores for replacement within 45 days from the date of intimation from Division filter unit / Stores and lift the failed material / equipment for repair rejected material after replacement. For this purpose, bidder shall maintain spare stock in adequate quantity of ordered ratings of material / equipment. If the defective material is not replaced / repaired within the specified period as above, the Maharashtra State Electricity Distribution Company Ltd. shall retain an equivalent end cost of material plus 15% supervision charges from any of the bills of the supplier or encashing available performance bank guarantee submitted against guarantee period or through any available sources, till the return of the equipment. No interest will be paid on the amount so retained / recovered. In case of material / item not returned duly repaired within 45 days, penalty shall be imposed @ 0.5% per week or part thereof maximum up to 10% of the cost of undelivered material / equipment beyond specified time limit. In case of material / item not returned duly repaired within 5 months, total cost of the material / item along with penalty will be adjusted / recovered from the pending bills of the supplier or encashing available performance bank guarantee submitted against guarantee period or through any available sources with MSEDCL.

The guarantee period failed material / equipment will be made available at MSEDCL filter unit. Loading and unloading of guarantee period failed material / equipment should be arranged by the supplier.

The clause itself shall be the notice to the supplier about encashment of PBG to adhere to the timelines.

The outage period, i.e. the period from the date of failure till unit is repaired / replaced shall not be counted for arriving at the guarantee period. Thus supplier has to extend the guarantee period by outage period.

Further, in case of repeated failures of equipments / material, the Purchaser reserves the right to debar / disqualify the supplier for future tenders / orders.

**20) LIFTING OF MATERIALS:****A) LIFTING OF REJECTED/DAMAGED MATERIALS FROM STORES:**

(a) On failure to replace or repair the transit damaged or rejected material within one month from the date of intimation as required under tender, it shall be deemed to have concluded that such material is finally rejected. The damaged / rejected material shall be lifted by the supplier within 30 days from the date of receipt of notice to that effect from the concerned consignee on reimbursement to the Purchaser of the cost of the material / equipment, if any, already paid in terms of payment clause in the contract and actual expenses incurred by the consignee towards handling, demurrage / wharfage / undercharges, freight, insurance premium etc. The Purchaser shall not be responsible in any case for the loss, destruction, damage, deterioration of the material after expiry of the said 30 days period.

(b) If the supplier fails to lift the material within this period, the material will remain with the Purchaser at the cost and risk of the supplier. Supplier shall, therefore, be liable to

pay ground rent @ 0.1% (Plus GST as may be applicable) per day of purchase cost of the material to be lifted from the date of intimation of rejection till the actual date of lifting.

- (c) The Purchaser will give 7 days' notice for lifting of rejected material and if not lifted, will be also free to Scrap / dispose of such material, after the period of said 37 days, by Public auction/Tender notice/Destruction as may be deemed fit and storage charges @ 0.1 % (Plus GST as may be applicable) per day of purchase cost will be recovered from the date of intimation of rejection of materials till the date of realization of the sale amount/physical removal of the material besides the actual expenses incurred as referred to at (a) above. The amount received from the sale of scrap/rejected material will be adjusted in the penalty.

Notwithstanding what is contended in the foregoing clauses, the supplier shall be liable to pay the Purchaser the cost and expenses incurred by the Purchaser, if any, including ground rent and the same shall be appropriated and recovered from the sale proceeds.

**B) LIFTING OF FAILED MATERIAL / EQUIPMENT FROM DIVISION FILTER UNIT:**

- a) If the supplier fails to lift the failed material within specified period, the material will remain with the Purchaser at the cost and risk of the supplier (By recovering end cost of failed transformer). The Purchaser will be also free to dispose of such material, after the period of 5 months from the date of intimation of failure by Public auction / Tender notice / Destruction as may be deemed fit or repaired departmentally and recovered cost will not be refunded to supplier.
- b) Process for lifting of rejected / damaged / failed materials from Divisions / Stores:
- i. The communication / correspondence shall only be made by specified e-mail id [cemmcmsedcl@gmail.com](mailto:cemmcmsedcl@gmail.com) by MSEDCL field offices / the supplier.
  - ii. As soon as the material/equipment is failed within guarantee period, the concerned Executive Engineer of O&M Division / Stores-in-charge shall inform the intimation of such failure immediately to Supplier as well as Material Management Department, Head Office on specified e-mail id in Format A (failure report).
  - iii. The Material Management Department will forward the format A to SB Section, Head office to withhold the payment equivalent to the cost of material/equipment with 15% supervision Charges from any of the bills of the supplier. If the supplier fails to return repaired transformer at concern O&M Division / Store within 45 days from the date of intimation, penalty to be imposed @ 0.5% per week or part thereof maximum up to 10%.
  - iv. On receipt of material/equipment against replacement or repairs, the Executive Engineer, O&M Division / Store-in-charge will issue Format C (Rectification report) to concern supplier with copy to Material Management Department Head Office through specified e-mail id.
  - v. The supplier shall note that the guarantee period for the delayed period taken for replacement / repairing of material/equipment will be automatically extended.
  - vi. Material Management Department Head Office shall inform the SB Section, Head office to release the payment withheld against that material/equipment.
  - vii. From the date of intimation, if supplier fails to return repaired material/equipment at O&M Division / concern store within 5 months, concerned Executive Engineer of O

=====

& M Division / Stores-in-charge shall inform the intimation of such failure immediately to Material Management Department, Head Office on specified e-mail id.

- viii. The Material Management Department Head Office shall forward the same to SB Section, Head office to recover the payment equivalent to the cost of material/equipment from any of the bills of the supplier with penalty to be imposed @ 0.5% per week or part thereof maximum up to 10% for final recovery as per clause 19.

**21) LIQUIDATED DAMAGES FOR LATE DELIVERY:**

In case the materials are not delivered within the period stipulated in the order, the supplier shall be liable to pay at the discretion of the competent authority of the Purchaser, the liquidated damages to the Purchaser @ 1% per week or part of week on the value of delayed material / unexecuted quantity plus taxes as applicable, if any on the price subject to a maximum of cumulative ceiling of 10% reckoned on the contract value of such complete portion or section of the plant, equipment or material delayed and also the portion supplied which could not be brought into commission due to any part thereof not having been delivered in time. In addition to above if bidder fails to supply the material within contractual delivery period continuously for 3 lots, then the order shall be liable for cancellation.

Due consideration may be given in the levy of liquidated damages for reasons absolutely beyond the control of the supplier, for which documentary evidence shall be produced to the satisfaction of the competent authority of the Purchaser.

The Purchaser shall be entitled to deduct/recover the amount of liquidated damages from the current bill payable to the supplier or any other amount due or payable to him against this or any other contract.

For computing the liquidated damages for delayed supplies, the date of railway receipt or the date of receipt of materials at stores in case of road transport, shall be the date of delivery.

In case the Purchaser does not arrange for inspection of material within 10 days from the date of receipt of inspection call to MSEDCL wherever applicable, the period of more than 10 days till inspection will not be considered for levy of liquidated damages. For computing the period taken for inspection in such cases, the relevant date mentioned in the inspection certificate issued by the inspecting officer would be considered.

**22) ORDER PLACED ON TIME PREFERENCE BASIS (WHEREVER APPLICABLE):**

In case of order on time preference basis (i.e. orders given at higher rate on delivery period considerations only) if order is given at higher rate of L-2 (or L-3 etc.), then the payment at higher rates will be made provided the firm makes supplies within the stipulated time period. In case of delay in supplies, the payment will be made at the rates offered by L-1. In addition, Clause No.21 above for Liquidated Damages for late delivery will also be applicable. However, the quantity allocation for order under this clause shall be at the sole discretion of MSEDCL & the specified quantity allocation for this tender will not be applicable in this case.

**23) FORCE MAJEURE CLAUSE:**

If, at any time, during the continuance of this contract the performance in whole or in part by either party of any obligation under this contract shall be prevented or delayed by reason of any war, hostility, acts of the public enemy, civil commotion, sabotage, fires, floods, explosions, epidemics, quarantine restriction, strikes, lock-outs or acts of God (herein after referred to as "events"), provided notice of happening of any such eventuality is given by either party to the other within 21 days from the date of occurrence thereof, neither party shall be by reason of such

event, be entitled to terminate this contract nor shall either party have any claim for damages against the other in respect of such non-performance or delay in performance; and deliveries under the contract shall be resumed as soon as practicable after such event has come to an end or ceased to exist, and the decision of the purchasing officer as to whether the deliveries have been so resumed or not, shall be final and conclusive, provided further that if the performance in whole or part of any obligation under this contract is prevented or delayed by reason of any such event for a period exceeding 60 days, either party may at its option terminate the contract PROVIDED ALSO that if the contract is terminated under this clause, the purchaser shall be at liberty take over from the contract at a price to be fixed by the purchasing Officer which shall be final all unused, undamaged and acceptable materials, bought out components and stores in course of manufacture in the possession of the contractor at the time of such termination or such portion thereof as the purchaser may deem fit accepting such material, bought out components and stores as the contractor may with the concurrence of the purchaser elect to retain.

**24) ACCEPTANCE OF LOWER FORD RATE OFFERED IN SUBSEQUENT TENDER :**

During contractual delivery period of supply, the quoted rates shall remain the same, however for same specification of material if the rates will receive lower in another subsequent tender in extended period of contract then it is binding on the supplier to supply the same material at lower rate for balance quantity of material i.e. in case if price bid of next subsequent tender of similar technical specification is opened and FORD rate found lower than the ongoing contracts this FORD rate shall be made applicable for the balance quantity beyond contractual delivery period. Further the purchaser reserves the right to allow the supplier to deliver the quantity or otherwise beyond the contractual delivery period.

However other stipulations of clause No. 23 of Section-II i.e. Annexure-A will remain unchanged.

**25) PERFORMANCE OF CONTRACT:**

The Purchaser will not be in any way liable for non-performance either in whole or in part of any contract or for any delay in performance thereof in consequence of strikes, shortage, non-availability of raw materials, combination of labour or workmen or lockout, breakdown or accident to machinery or accidents of whatever nature, failure on the part of the railways to supply sufficient wagons to carry essential raw materials etc. and finished products from the stores, subject to the provision and stipulation made in condition No. 21 as stated above i.e. Liquidated damages for late delivery.

**26) CONTRACT PERFORMANCE DEPOSIT:**

- a) The supplier will have to furnish contract performance deposit as per Annexure - N in the form of unconditional & irrevocable BG in electronic form (e-BG) within 15 days from the date of issue of LoA, as mentioned in Clause 26.2.
- b) The contract performance deposit shall be an amount equal to 5% of the contract value and shall be valid for a period of 90 days beyond guarantee period of the last lot of the equipment supplied.
- c) The contract performance deposit shall be refunded within 90 days from the date of expiry of the guarantee period of the equipment supplied. The purchaser shall not be liable to pay any interest or compensation to the contractor for retaining the deposit after the end of the said period.

- d) The contract performance deposit is intended to secure the performance of the contract for guarantee period of the equipment supplied. However, it is not to be construed as limiting the damages stipulated in other clauses of the contract.

**27) POWER OF ATTORNEY:**

It will be obligatory on the supplier to communicate the revocation of Power of Attorney, if any, after submission of offer till the execution of contract failing which the act/s & action done by the agent / representative shall be deemed to be the valid act/s & action of the bidder / supplier.

**28) SETTLEMENT OF DISPUTE:**

Permanent Dispute Resolution Committee (PDRC) comprises of Chief Engineer (MM Dept.), one member of Accounts Department and representative of supplier will resolve the dispute arise if any.

**29) JURISDICTION:**

Any disputes or difference arising under, out of or in connection with this tender or contract if concluded, shall be subject to the exclusive jurisdiction of the "Courts" in Mumbai.

**30) TERMINATION OF CONTRACT**

- 1) The decision of the Purchaser shall be final as regards the acceptability of the stores supplied by the supplier and the Purchaser shall not be required to give any reason in writing or otherwise at any time for the rejection of the stores/materials.
- 2) In case the contractor/supplier fails to deliver the stores/material or any consignment thereof within the contracted period of delivery as per delivery schedule or in case the stores/materials are found not in accordance with the prescribed specification and the performance of the supplied material is not found satisfactory, the Purchaser shall exercise in discretionary power either,
  - a) To purchase from elsewhere, after giving 15 days due notice to the contractor, at the risk of contractor, such stores/material not so delivered or other of similar description, without cancelling the contract in respect of consignment not yet due for delivery,
  - OR
  - b) To cancel the contract reserving Purchaser's right to recover damages Plus GST as may be applicable.
  - c) notwithstanding that the powers under (a) and (b) referred above are in addition to the rights and remedy available to the Purchaser under the General Law of India relating to contract.
  - d) Purchaser reserves right to recover damages against risk purchase or 10% value of non-supplied material plus applicable taxes, if any whichever is higher.

In the event of risk purchase of stores of similar description, the option of the Purchaser shall be final. In the event of action taken under (a) or (b) above, the supplier shall be liable for any loss which the Purchaser may sustain on that account but the supplier shall not be entitled to any saving on such purchases made against default.

- 3) Further contract can be terminated in case of sub-standard /poor quality material.

=====

**31) DEBAR / BLACKLISTING OF MANUFACTURER:**

In the event of fraudulent practices / non-compliance / non fulfillment of any obligation as required by MSEDCL at any stage of tendering or execution, the bidder is liable to be debarred / blacklisted at the discretion of MSEDCL.

**32) TAX DEDUCTED AT SOURCE:**

The purchaser shall deduct tax at source in accordance with the provisions of the laws as and when the same is notified.

## SECTION-III

### I. Quantity procurement :

The quantity for procurement is as below.

Material Code	Material Details	Quantity (Nos.)	Estimated Cost (Rs. Crore)
20119986513	11/0.433 kV, 630 KVA Three Phase, Copper Wound, CRGO Core, ONAN, Indoor Distribution Transformer EEL- II ( STAR-II)	118	20.29
20119986773	22/0.433 kV, 630 KVA Three Phase, Copper Wound, CRGO Core, ONAN, Indoor Distribution Transformer EEL- II ( STAR-II)	216	40.79
Total		334	61.08

### II. Qualifying Requirements:

1. The bidder shall be an Original Equipment Manufacturer (OEM) and possess valid BIS license (If applicable) and BEE certificate (If applicable) as per clause no XIV.

Upload:

- a) BIS License and BEE certification.

2. The bidder should have experience for supply of similar or higher rating of material / equipment of any voltage level for Energy Efficient Level-1 or Energy Efficient Level-II to any Electricity Distribution Utility, Electricity Distribution Franchisee or Public Sector Undertaking and should have executed orders of 30% of tender quantity for offered item during last three (3) financial years.

Bidders who supplied the material in MSEDCLs projects viz; INFRA - II, IPDS, DDUGJY, DPDC, DDF, Non DDF, HVDS or any other scheme will be considered & bidder shall produce the order completion / quantity supplied certificate from concern Superintending Engineer (Infra/O&M).

Upload:

- a) Copies of orders executed by the bidder and the Certificate from the purchaser with regards to successful execution of the order / supply of quantity for preceding three financial years.
- b) List of orders in hand.

3. For all tendered material, valid Type test certificates (If applicable) as per MSEDCLs technical specifications (Annexure-D) which are carried out within 5 years prior to the date of opening of tender from NABL accredited lab such as CPRI / ERDA shall be uploaded in the bid. Bids without the Type test certificates shall not be considered for further evaluation.

Upload:

- a) Type test certificates from NABL accredited lab such as CPRI/ERDA valid for a period of five years.

4. Average Annual Turnover – The Average annual turnover of last three financial years of the bidder shall be 30% of the tender estimated cost of offered item. The bidder has to submit the annual turnover certificate of the company of last three financial years duly certified by Chartered Accountant.

Upload:

- a) Documentary evidence showing annual turnover of last 3 years, certified by Chartered Accountant for preceding three financial years. (As per attached Format-4)
5. The bidder should have in-house testing facilities for conducting acceptance & routine tests in accordance with the procedures laid down in relevant IS /IEC amended up to date.

Upload:

- a) List of in house manufacturing and testing facilities as well as quality control set up.
6. The bidder shall have ISO certification for quantity management system & environmental management system.

Upload:

- a) ISO for quality management system.
  - b) ISO for environmental management system.
7. The bidders who quoted under New Suppliers category are exempted from experience and turn over criteria. Bidder has to submit the Annexure-O regarding declaration of participation as New Supplier in the tender failing to which it will be presumed that bidder has participated in the tender as Regular Supplier. Once the Annexure-O is submitted in the offer it will not be changed at any stage of process and qualification will be done as per Annexure-O only.

Upload:

- a) Annexure-O regarding declaration of participation as New Supplier / Regular Supplier (item wise) in the tender.
8. Following Documents should be submitted by the bidder along with the bid.

Upload:

- a) Documentary evidence (for e.g. Udyam Registration/NSIC/Chartered Accountant/Engineer Certificate) for manufacturing capacity to cover the quantity offered by the bidder and considering orders in hand.
- b) Certificate from Chartered Accountant for not having controlling stake in more than one entity as per attached Format-3.
- c) Annexure-F regarding declaration of legal litigations.
- d) Annexure-I regarding debar undertaking.
- e) Self-undertaking on bidders letter head for not approaching any one for undue influence as per attached Format-2.
- f) GST registration certificate.
- g) EMD receipt (E-Bank Guarantee or Demand Draft)
- h) Power of attorney.
- i) Certificate for No Deviation as per attached Format-5.

**Note:** If there is any ambiguity in other terms & conditions, this Section-III prevails.

**ANNEXURE - "B"**  
QUANTITY, PRICE AND DELIVERY PERIOD

**ANNEXURE - "B" to be submitted online against commercial bid; attached separately**

-----  
**ANNEXURE 'C-I'**

**[To be submitted later on as per as per Clause XVIII (B) of Instructions]**  
**CONFIRMATION FOR ACCEPTING ORDER BY MATCHING RATES WITH LOWEST**  
**ACCEPTABLE BIDDER**

**APPLICABLE FOR INDUSTRIAL UNITS FROM MAHARASHTRA ONLY** Marketing Assistance and Purchase Preference to the units from Maharashtra (refer Clause XVIII of Instructions to Bidders):-

- 1. In case your unit is located in Maharashtra and the
  - (a) lowest acceptable rate received against the tender is from the unit outside Maharashtra, please confirm whether you are agreeable to accept order at that lowest acceptable rate limited to 50% (fifty percent) of our requirement. ....

**APPLICABLE FOR ALL BIDDERS INCLUDING THOSE ELIGIBLE UNDER THE ABOVE CLAUSES:**

- 1. Please confirm whether you are agreeable to accept
  - (b) order at the lowest acceptable rate received against the tender. ....

[Industrial units from Maharashtra can give option under 1(b) above for balance quantity]

Note:-

- 1. If the bidder gives the above confirmation for the quantity less than as indicated in Clause X (iii) of the Instructions to the Bidders, then the above confirmation shall not be acceptable.
- 2. Bidders may confirm matching for one or more items originally tendered.
- 3. Any withdrawal of confirmation for order by matching rate within validity of offer will render the entire offer invalid and shall be summarily rejected and Earnest Money Deposit shall stand forfeited.
- 4. A bidder will not be entitled to the benefit of offers by matching rates and will not be considered for orders if his original offer is rejected on the ground of ambiguity or because of not accepting /noncompliance of the terms & conditions of the tender.
- 5. In the above confirmation, if the bidder indicates any rate, then the above confirmation given by the bidder will not be considered as valid.

**ANNEXURE- 'D'**

TECHNICAL SPECIFICATION

As Indicated in E-Tendering



**ANNEXURE-0**  
**(On bidders' letter head)**

**CONSENT FOR PARTICIPATION IN TENDER AS NEW SUPPLIER**

I/We, ..... have understood and checked the tender documents for supply of -----  
----- and have not found any errors in them.

I/We hereby declare and confirm that we are participating in the tender no.....as New Supplier / Regular Supplier for particular rating as specified in the following table and agree to supply the material as per terms and conditions of the said tender.

Sr. No.	Item Description	Regular Supplier (Yes/No)	New Supplier (Yes/No)
1	-----		
2	-----		

Note: 1) Bidder has to provide only one “Yes or No” against particular rating.

- 2) If for any particular rating bidder has given the option “Yes” for both the types (Regular & New Suppliers) then option for “Regular Supplier” will be considered and evaluation will be carried out as per Regular Suppliers criteria only.
- 3) If for any particular rating bidder has given the option “No” for both the types (Regular & New Suppliers) then it will be presumed that bidder has not quoted for that particular rating.

Yours faithfully,

Signature & Seal of company,

In the capacity of duly authorized to sign bids for and on behalf of

Address:

=====

**Annexure-F**

(On supplier's Letter Head)

I, ..... certify that,

The business dealings with our firm / agency M/s..... and its sister concern/Director/Partner/Proprietor have no any type of legal litigation against MSEDCL is pending in any court/Forum against/by the bidder or its sister concern/Director/Partner/Proprietor.

If it is found at any stage of tendering and order execution process then as per the tender conditions our offer will be rejected and I /We don't have any objection on the same.

I hereby certify that I am duly authorized representative of M/s.----- whose name appears above my signature.

Bidders Name:

Authorized representative's signature:

Authorized representative's Name:

Seal of the company

Name and address of the Bidder

Date:

---

**Annexure-G**

**PRICE VARIATION CLAUSE**

**Not Applicable**

Annexure - H

GUARANTEED TECHNICAL PARTICULARS

As indicated in E-Tendering GTP Parameter

Annexure- I

(On supplier's Letter Head)

I, ..... certify that,

- a. The business dealings with our firm / agency M/s..... have not been debarred by any Ministry of GoI / GoM / state owned electricity distribution utility and still in force.
- b. The Directors, Proprietors, Partners, Employee(s) or owner of our firm / agency M/s..... have not been either jointly or severally guilty of malpractices in relation to its business dealings with the Government or MSEDCL during the last five years.

I hereby certify that I am duly authorized representative of M/s.----- whose name appears above my signature.

Bidders Name:

Authorized representative's signature:

Authorized representative's Name:

Seal of the company

Name and address of the Bidder

Date:

=====

## Annexure- J

(On MSEDCL Letter Head)

Dispatch Instructions

BY R. P. A. D. / ORD. POST /E-MAIL

(SAP CONTRACT No: -----)

To,

M/s. -----

Email: -----

Sub: Supply of ----- against A/T No. ----- dt. -----

Ref: Final Inspection Call letter No. ----- dt. -----.

(I.W. Regn. No. ----- dt. -----)

Your readiness of material letter no. .... dtd.....

Dear Sir,

With reference to the above, you are requested to dispatch ..... transformers as given below:

Sr. No.	Consigned to	Meant for Circle	Meant Zone	for	Qty. in Nos.

Further, you are requested to contact concerned S.E. (O&M) Circle / E.E. (O&M) Division / Addl. E.E. (MM Section) before dispatching / unloading the above material.

This is issued without prejudice to all other terms and conditions of the order.

Yours Sincerely,

Chief Engineer (M M Dept.)

Copy f.w.cs.to: The C.E., MSEDCL, -----.

Copy to:

The G.M. (F & A – SB), MSEDCL, Mumbai.

The E.E. (IW), MSEDCL, Mumbai.

The E.E. (O & M Division), MSEDCL, -----

The Addl.E.E. (MM Section), MSEDCL, -----

## Annexure- K

### List of Stores

Sr. No.	Name of Stores	Address
1	Common Stores Ahmednagar	Nagar-Pune Road, Opp. Arti Hotel, Kedgaon, Ahmednagar.
2	Common Stores Airoli	Power House, Thane-Belapur Road, Airoli, Navi Mumbai.
3	Common Stores Akola	Major Store Babhulgaon NH No 6 Akola.
4	Common Stores Amravati	Major Store MSEDCL Power House, Mulshi Road, Amravati.
5	Common Stores Aurangabad	MIDC Plot No. J-13, Opp. Garware Stadium, Naregaon Phata, Chikhalthana, Aurangabad.
6	Common Stores Beed	Near 132 kV Sub-station, Idgah Nagar, Nalvandi Naka, Beed.
7	Common Stores Chandrapur	Near Vidyut Bhavan, Bagala Chaowk, Babu Peth, Chandrapur.
8	Common Stores Jalgaon	Old MIDC Area, Behind Ajanta Lawns, Ajanta Road, Aurangabad Highway, Jalgaon.
9	Common Stores Kalyan (Netivali)	MIDC Phase 1, Near Tata Power House, Kalyan - Dombivali Road.
10	Common Stores Kamptee	Maldhakka Godown, Behind Railway Station Kamatee, Nagpur.
11	Common Stores Khamgaon	Manav Dharm Bld. Near 132 kV Sub-Station, Shegaon Road, Khamgaon, Dist. Buldhana.
12	Common Stores Kolhapur	Kaneri Math Road, A/P Gokulshirgaon, Tal. Karveer, Dist. Kolhapur.
13	Common Stores Kudal	Malwan Road, MIDC Pinguli-Nerur, Kudal, Sidhudurg.
14	Common Stores Latur	MIDC Plot No. P-21/P, In Front of Kirti Gold Oil Mill, Latur.
15	Common Stores Mulshi	Phursungi-Saswad Road, Near Overhead Bridge, Mulshi/ Phursungi, Dist. Pune.
16	Common Stores Nanded	Taroda Naka Main Road, Nanded.
17	Common Stores Nashik	Aringale Plot, Hanuman Nagar, Jail Road, JunaSaykheda Road, Panchak, Nasik.
18	Common Stores Osmanabad	Near MSEDCL Rest House, Tuljapur Road, Osmanabad.
19	Common Stores Palghar	Near 33/11 kV Sub-Station, MSEB Coloney, Boisar Road, Palghar.
20	Common Stores Parabhani	Old Power House Jintur Road, Parbhani.
21	Common Stores Ratnagiri	MIDC Area Mirjole, Kuwarbav, Ratnagiri.
22	Common Stores Sangli	Near Walchand Engineering College, VishramBaug, Sangli.
23	Common Stores Satara	A/P Satara, Tal. Koregaon, Dist. Satara.
24	Common Stores Solapur	Plot No P-4, MIDC Chincholi, Behind Post Office, Solapur
25	Common Stores Tumsar	Near Power House, Nakaq Dongari Road, Old Bus Stop, Tumser, Bhandara.
26	Common Stores Yavatmal	MIDC Lohara, Yavatmal.

=====

**ANNEXURE – L**

**Format for Inspection Call Readiness of Material**

**Ref. No.****Date:**

To,  
The CE (MMD),  
Prakashgad, Bandra (E),  
Mumbai - 400051.

**Sub:** Inspection Readiness of material against A/T No. ----- dated. ----- for  
Supply of -----.

-----

1. Brief description of the material Offered for inspection:
2. Reference of drawing Approval :
3. a) Reference of approval of type test:  
b) Reference of approval of balance type test (If applicable):
4. Whether it is a joint inspection with Testing SE (TQA) etc. (if applicable):
5. a) Whether Performance Deposit has been paid against the order:  
b) if paid, please give details:
6. Sr. No. of the items as per A/T:
7. Total Quantity of the items Ordered:
8. Total quantity of the items inspected so far:
9. a) Quantity monthly committed in delivery schedule:  
b) Lot No. for which the Quantity is offered for inspection now:  
c) Due date of delivery as per A/T for offered quantity:
10. Date of readiness of Material:
11. Complete address of the factory where materials is to be inspected:
12. Name of the person to be contacted in connection with inspection & his  
Office/Factory/Residence Tel. No.:
13. Staggering holiday of Factory/Office at the place of inspection:
14. a) Whether Dispatch Instructions are available (Say Yes or No):  
b) Quote Letter No.:  
c) Brief destination & Qty. per consignee of this present lot offered:
15. Last visit of our Inspecting Officer:
16. a) Whether the entire material is dispatched against last inspection. (Our EE[IW]  
will ensure before inspection of this lot that the earlier inspected lot is already  
dispatched)  
b) Quantity dispatched
17. Further programme of production Quantity likely to be offered & by what date:

Authorized Signature  
For (Name of the Firm).

## ANNEXURE - M

## E-BANK GUARANTEE FORMAT

**EARNEST MONEY DEPOSIT E-BANK GUARANTEE AGAINST TENDER**

[In electronic form only]

Bank Guarantee No.: \_\_\_\_\_

Date: \_\_\_\_\_

Amount: ₹ \_\_\_\_\_ (Rupees \_\_\_\_\_ only)

Validity: Up to \_\_\_\_\_

Claim Period: Up to \_\_\_\_\_

To,

The Chief Engineer (MMD),  
Material Management Department,  
Maharashtra State Electricity Distribution Co. Ltd.,  
Prakashgad, 1<sup>st</sup> Floor,  
Prof. Anant Kanekar Marg, Bandra (East),  
Mumbai -400 051, Maharashtra, India

Dear Sir,

We, [**Name of Bank**], having our branch at \_\_\_[**Complete branch address**]\_,  
**Bank IFSC Code:**\_\_\_ **Bank e-mail id:**\_\_\_\_\_ (hereinafter called "*the Bank*") hereby  
agree unequivocally and unconditionally to pay, at Mumbai within 48 hours, on demand in  
writing from the MAHARASHTRA STATE ELECTRICITY DISTRIBUTION CO. LTD. (M.S.E.D.C.L.)  
(formerly known as M.S.E.B.) on behalf of M/s \_\_\_\_\_ (Address as per MSEDCL  
REGISTRATION) who have tendered and/or contracted or may tender or contract hereafter for  
supply of materials. Equipments or services to the MAHARASHTRA STATE ELECTRICITY  
DISTRIBUTION CO. LTD. against Tender No. ----- dated ----- total value  
of Tender is Rs. -----

This agreement shall be valid and binding on this Bank up to and including validity (date)  
and shall not be terminable by notice or any change in the constitution of the Bank or the firm of  
contractors or any other reasons whatsoever and our liability hereunder shall not be impaired  
or discharged by any extension of time or variations or alternations made given conceded or  
agreed with or without our knowledge or consent by or between parties to the said within  
written contract. The validity of this Bank Guarantee will be extended by us for the further  
period of six months, one month prior to its present validity period at the request of  
MAHARASHTRA STATE ELECTRICITY DISTRIBUTION CO. LTD. (M.S.E.D.C.L.) (formerly known  
as M.S.E.B.).

=====

In case of any dispute arising out or in connection with the extension or encashment of Bank Guarantee, the Courts in Mumbai will have jurisdiction.

Our liability under this Guarantee is restricted to Rs.-----/- (Rupees----- only). Our Guarantee shall remain in force until (date). Unless a suit or action to enforce a claim under the guarantee is filed against us within six months from the aforesaid date, all your rights under the said guarantee shall be forfeited and we shall be relieved and discharged from all liability there under.

Digital Signature of Bank Employee 1:

Date:

Place:

Digital Signature of Bank Employee 2:

Date:

Place:

Please note that:

1. The value of non-judicial stamp paper for this Bank Guarantee is Rs.500/- should be purchased in the name of Guarantor Bank.
2. The Bank Guarantee should be furnished from any Scheduled Bank/Nationalized Bank.
3. Please state the full and complete postal address of the Bank, Bank IFSC Code, Bank e-mail id undertaking the guarantee.
4. Digital Signature of minimum two Bank employees are required on the Bank Guarantee document.
5. The Bank Guarantee may be valid as per terms and condition of tender document.
6. B.G. should be submitted along with covering letter of Bank.
7. Beneficiaries bank details for issuance of e-BG is as below:

Sr.No.	Particulars	Details
1	Name of Beneficiary and detailed address with Pin Code	Chief Engineer (MMD), Material Management Department, Maharashtra State Electricity Distribution Company Ltd.(MSEDCL),Bandra-400051
2	Beneficiary's Legal Constitution	State Govt.Undertaking Co.
3	Beneficiary	MSEDCL
4	Beneficiary's Date of Incorporation	31.05.2005
5	Beneficiary PAN / UIN / TIN No.	AAECM2933K
6	Beneficiary GSTIN No.	27AAECM2933K1ZB
7	Beneficiary TAN No.	MUMM27406B
8	Beneficiary BU Code	NOT APPLICABLE
9	Beneficiary's Representative Name	Chief Engineer(MMD)
10	Beneficiary's Representative Mobile No.	9619897606
11	Beneficiary's email ID	srmgrmsedcl@gmail.com
12	Beneficiary Bank Name, address, and IFSC Code for transmitting SFMS	Name of Bank: BANK OF MAHARASHTRA Bank Branch: FORT, MUMBAI Bank Account No.: 20045003931 IFSC Code: MAHB0000002

## ANNEXURE - N

## E-BANK GUARANTEE FORMAT

## FORM OF E-BANK GUARANTEE FOR THE PERFORMANCE OF THE EQUIPMENT

[In electronic form only]

Bank Guarantee No.: \_\_\_\_\_

Date: \_\_\_\_\_

Amount: ₹ \_\_\_\_\_ (Rupees \_\_\_\_\_ only)

Validity: Up to \_\_\_\_\_

Claim Period: Up to \_\_\_\_\_

To,

The Chief Engineer (MMD),  
Material Management Department,  
Maharashtra State Electricity Distribution Co. Ltd.,  
Prakashgad, 1<sup>st</sup> Floor,  
Prof. Anant Kanekar Marg, Bandra (East),  
Mumbai -400 051, Maharashtra, India

Dear Sirs,

**WHEREAS:**

M/s. \_\_\_\_\_, having its registered office at \_\_\_\_ (Postal address as per A/T)\_\_\_\_ (hereinafter called "*the Supplier*"), has entered into a Contract to supply \_\_\_\_ (Name of Material as per A/T)\_\_\_\_ to the MAHARASHTRA STATE ELECTRICITY DISTRIBUTION COMPANY LTD.(M.S.E.D.C.L.) (formerly known as M.S.E.B. ) (hereinafter called "*the Employer*") having its Registered Office at Prakashgad, Prof. Anant Kanekar Marg, Bandra(East), Mumbai-400051,Maharashtra, India against Acceptance of Tender/Letter of Award no. \_\_\_\_\_ dtd. \_\_\_\_ **(DD-MM-YYYY)** \_\_ on the terms and conditions in the said contract (hereinafter called "*the Contract*").

As per the terms of the Contract, the supplier **M/s.** \_\_\_\_\_, having its registered office at \_\_\_\_ (Postal address as per A/T)\_\_\_\_ shall submit the contract performance guarantee for an amount of ₹ \_\_\_\_\_ **/- (Rupees \_\_\_\_\_ only.)**, equivalent to \_\_\_\_\_ % ( \_\_\_\_\_ Per cent) of the Contract value including GST i.e. ₹ \_\_\_\_\_ **/-(Rupees \_\_\_\_\_ Only)**, to secure due and faithful performance of the Contract.

We, [**Name of Bank**], having our branch at \_\_\_\_ [**Complete branch address**]\_\_\_\_, **Bank IFSC Code:**\_\_\_\_ **Bank e-mail id:**\_\_\_\_ (hereinafter called "*the Bank*"), at

=====

the request of M/s \_\_\_\_\_ having its registered office at \_\_\_\_\_ has agreed to give this guarantee.

**NOW THEREFORE THIS DEED WITNESS AS FOLLOWS:**

We, [**Name of Bank**], having our branch at [**branch address**] hereby unequivocally and unconditionally undertake and guarantee as principal obligators on behalf of the Supplier that in the event the Employer submits a written demand to us stating that the Supplier has not performed according to the terms and conditions of the Contract , we will pay you on demand and without demur and without the right of the Supplier to dispute or question such demand any sum upto a maximum amount of ₹ \_\_\_\_\_ /- (**Rupees \_\_\_\_\_ only.**), equivalent to \_\_\_\_\_ % ( \_\_\_\_\_ Per cent) of the Contract Value including GST i.e. ₹ \_\_\_\_\_ /-(**Rupees \_\_\_\_\_ Only**).

**THE BANK HEREBY UNDERTAKES THAT:**

1. The Bank hereby guarantee to the Employer the due performance and observance by the Supplier of the terms and conditions of the contract.
2. The Bank also agrees that it shall not revoke this guarantee during its currency or during the period of its execution, even by giving notice to the Employer.
3. On account of the non-fulfillment of the contractual obligation by the Supplier or in case the Bank or Supplier do not renew this guarantee bond as herein provided, the Bank will on simple demand from the Employer, pay at Mumbai to the Employer, the sum of ₹ \_\_\_\_\_ /- (**Rupees \_\_\_\_\_**), without demure and without the Employer to invoke any legal remedy that may be available to them to compel the Bank to pay the same even if the Supplier consider such demand of the Employer unjustified.
4. The Bank agrees and declares that notwithstanding anything contained in Section 133 to 135 of the Indian Contract Act 1872 (IX of 1972) or any other rule of law or equity in the view of any variance in the terms of the said contract shall not operate as a discharge of his obligations hereunder or shall any composition made by the Employer with Supplier in respect of any breach of the terms and conditions of the said contract operate as a discharge of the Bank's obligation and Bank further expressly agrees and declares that though as between the Employer and Bank, the Bank shall be liable for sum payable or falling due hereunder equally with the Supplier and the Bank save as otherwise herein provided hereby waives all his rights which he might as guarantor be entitled to claim and enforce.

- 
5. The decision of the Employer that any sum has become payable shall be final and binding on the Bank.
  6. The guarantee shall come into force immediately w.e.f. date of issue and shall remain in force till the end of \_\_\_(DD-MM-YYYY) \_\_\_. The Bank, at the request of the Employer shall extend the validity of the Bank Guarantee from time to time for a further period of 12 months, one month prior to its present validity period.
  7. In case of any dispute arising out of or in connection with the extension or encashment of the Bank Guarantee, the courts in Mumbai will have the jurisdiction.
  8. This guarantee shall be a continuing guarantee (which means guarantee will also be valid if the bank is in under liquidation or bankruptcy) and shall not be discharged by any change in the constitution of the Bank or in the constitution of the Supplier.
  9. We hereby agree that any part of the Contract may be amended, renewed, extended, modified, compromised, released or discharged by mutual agreement between you and the Supplier, and this guarantee may be exchanged or surrendered without in any way impairing or affecting our liabilities hereunder without notices to us and without the necessity for any additional endorsement, consent or guarantee by us.
  10. Our liability under this guarantee is restricted to ₹ \_\_\_\_\_ /- (Rupees \_\_\_\_\_ only.) and our guarantee shall remain in force until \_\_\_(DD-MM-YYYY)\_\_\_ unless a claim under this guarantee is lodged with us within six months from the date of expiry of guarantee i.e. on or before \_\_\_(DD-MM-YYYY) \_\_\_ all your rights under this guarantee shall be forfeited and we shall be relieved and discharged from all our liabilities there under.

IN WITNESS WHERE OF THE Bank has executed this deed in presence of

Digital Signature of Bank Employee 1: Date: Place:
----------------------------------------------------------

Digital Signature of Bank Employee2: Date: Place:
---------------------------------------------------------

## Please Note:

- 1) The Bank Guarantee should be furnished in the prescribed electronic form from any Nationalized Bank/ Scheduled Bank along with covering letter of Bank.
- 2) The minimum value of non-judicial stamp paper for this Bank Guarantee is ₹ 500/-.
- 3) The stamp paper is to be purchased in the name of Guarantor Bank i.e. Bank Guarantee issuing Bank Only.
- 4) Please state the full and complete postal address of the Bank, Bank IFSC Code, Bank e-mail id undertaking the guarantee.
- 5) Digital Signature of minimum two Bank employees are required on the Bank Guarantee document.
- 6) The correct contract number (LOA /AT no.) and date, amount in Rupees is to be mentioned correctly in the Bank Guarantee document.
- 7) Name & Full address of the company is to be mentioned correctly in the Bank Guarantee document.
- 8) B.G. should be valid as per terms of contract including guarantee period of material.
- 9) Beneficiaries bank details for issuance of e-BG is as below:

Sr.No.	Particulars	Details
1	Name of Beneficiary and detailed address with Pin Code	Chief Engineer (MMD), Material Management Department, Maharashtra State Electricity Distribution Company Ltd.(MSEDCL),Bandra-400051
2	Beneficiary's Legal Constitution	State Govt.Undertaking Co.
3	Beneficiary	MSEDCL
4	Beneficiary's Date of Incorporation	31.05.2005
5	Beneficiary PAN / UIN / TIN No.	AAECM2933K
6	Beneficiary GSTIN No.	27AAECM2933K1ZB
7	Beneficiary TAN No.	MUMM27406B
8	Beneficiary BU Code	NOT APPLICABLE
9	Beneficiary's Representative Name	Chief Engineer(MMD)
10	Beneficiary's Representative Mobile No.	9619897606
11	Beneficiary's email ID	srmgrmsedcl@gmail.com
12	Beneficiary Bank Name, address, and IFSC Code for transmitting SFMS	Name of Bank: BANK OF MAHARASHTRA Bank Branch: FORT, MUMBAI Bank Account No.: 20045003931 IFSC Code: MAHB0000002

=====

**SCHEDULE C**

Quantity Offered at Column No. 6 of Annexure-'B' (Price Schedule):

Sr. No.	Item Code	Material Description	Quantity Tendered in Nos.	Quantity Offered at Column No. 6 of Annex- 'B'(Price Schedule) in Nos
1	2	3	4	5
1				
2				
3				

**Seal & Signature of Supplier**

=====

**FORMAT 1**

**ANNEXURE – U-I**

**“INDEMNITY BOND”**

UNDERTAKING TO BE SUBMITTED BY THE PARENT COMPANY SITUATED ABROAD IN CASE OF THE PARTICIPANT BIDDER WHO IS AN INDIAN BASED SUBSIDIARY ON GENERAL STAMP OF `200.00.

The Chief Engineer,  
Maharashtra State Electricity Distribution Co. Ltd.,  
Material Management Department,  
1<sup>st</sup> Floor, Prakashgad, Bandra (E),  
Mumbai – 400 056.

Dear Sir:

**Sub:** Undertaking against Tender No. \_\_\_\_ for procurement of \_\_\_\_\_

We, M/s. \_\_\_\_ having registered office at \_\_\_\_ are the Parent Company of M/s. \_\_\_\_ who have participated against your tender no. \_\_\_\_ for procurement of \_\_\_\_.

We have carefully read and have thoroughly understood and agree to the terms and conditions of the subject tender.

We hereby undertake that in case of placement of order against the subject tender on our subsidiary company, M/s. \_\_\_\_, in the event of we accept all the responsibilities and liabilities for supply of quality equipments as per specification of the tender and execution of the contract. We further hereby undertake that we shall be responsible for any liability arising out of the contract placed on M/s. \_\_\_\_ and to pay MSEDCL on demand the sum of rupees as per agreement in the event of any breach of condition of the purchase order, loss and damage of the material till expiry of guarantee period as stipulated in the order.

Our liability here under shall not be impaired or discharged by extension of time or variation or alteration made with or without our knowledge or consent by or between the parties to the said contract. This undertaking shall be valid and binding on us upto and including the execution and guarantee period of the order and shall not be terminable by notice or change in the constitution of any of the companies. In case of any dispute arising out of or in connection with this tender or contract, if concluded, the same shall be subject to the exclusive jurisdiction of the **“Court in Mumbai (India).”**

Yours faithfully,

(Authorised Signatory)

For \_\_\_\_\_

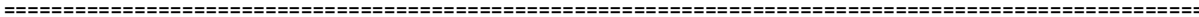

**FORMAT-2**

**Undertaking for not approached any one for undue influence.**

(To be submitted on letter head of the bidder)

Tender No. MMD/T-..... for supply of .....

**TO WHOM SO EVER IT MAY CONCERN**

I / We \_\_\_\_\_ hereby submit the undertaking that our firm or our partners or directors have not approached any one for undue influence against the Tender/Bid.

If it is found that we have given wrong or misleading information then our offer shall be summarily rejected.

**Date:**

**Place:**

(Signature, Name of Authorized Representative  
& Company Seal)

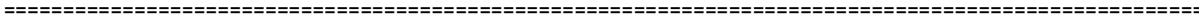

**FORMAT-3**

**Format of Certificate from Chartered Accountant for not have controlling stake in more than one entity applied for the Tender/Bid.**

(To be submitted on Letter Head of the Chartered Accountant)

Tender No. MMD/T-..... for supply of .....

**TO WHOM SO EVER IT MAY CONCEREN**

I \_\_\_\_\_ hereby certify that the firm M/s \_\_\_\_\_ or its partners or directors does not have controlling stake in more than one entity applied for the Tender/Bid.

If it is found that they have given wrong or misleading information then their offer shall be summarily rejected.

**Date:**

**Place:**

(Seal, Signature & Name of C.A.with Regn. No. & UDIN No.)

**FORMAT-4****Format of Certificate from Chartered Accountant for Average Annual Turnover**  
(To be submitted on Letter Head of the Chartered Accountant)

Tender No. MMD/T-..... for supply of .....

TO WHOM SO EVER IT MAY CONCEREN

We have examined the audited financials of M/s \_\_\_\_\_, having its registered office at \_\_\_\_\_, for the financial years. Based on our examination, we hereby certify that Annual Turnover for respective financial year mentioned below is in accordance with the audited financial statements:

Financial Year	Assessment Year	Annual Turnover Amount In Rupees Lakhs.
Total. Rs.		
(Rs. ... ..Figure in words)		
Average Annual Turnover Of Last Three Financial Years		

This certificate is given on the basis of copy of audited financial reports for profit/loss account and balance sheet.

Date:

Place:

(Seal, Signature &amp; Name of C.A. with Regn. No. &amp; UDIN No.)

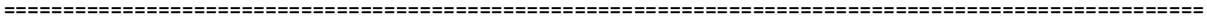

**FORMAT-5**  
Format for No Deviation Form  
(To be submitted on letter head of the bidder)

Tender No. MMD/T-..... for supply of .....

**CERTIFICATE FOR NO DEVIATION**

We, (Bidder's Name), hereby certify that there is no technical or commercial deviation from the Conditions mentioned in Tender Document and I am agreeing to all the terms and conditions mentioned in the Tender Specification.

Bidders Name:  
Authorized representative's signature:  
Authorized representative's Name:  
Seal of the company  
Name and address of the Bidder  
Date:

### Annexure 'B'(Price Schedule)

Sr.No	Item Code	Material Description	Unit	Quantity Required	HSN	Quantity Offered	Unit ExWorks including packaging charges but excluding duties & taxes etc (In Rupees )	Freight Charges Per Unit (In Rupees )	Transit Insurance Charge s Per Unit (In Rupees )	Integrated GST for outside State Transaction on (Ex-Works Price+Freight Charges + Transit Insurance Charges )(In Rupees)	Central GST for within State Transaction on (Ex-Works Price + Freight Charges + Transit Insurance Charges )(In Rupees)	State GST for within State Transaction on (Ex-Works Price + Freight Charges + Transit Insurance Charges)(In Rupees)	Free Door Delivery Price Per Unit by Road upto Destination/Stores/Sub Station (In Rupees)
1	2	3	4	5	6	7	8	9	10	11	12	13	14=(8+9+10+11+12+13)
1	20119986513	630KVA,11/0.4KV3phDT/ID/CRGO/Star2/EEL-2/5yGP	NO	118	85042100								
2	20119986773	630KVA,22/0.4KV3phDT/ID/CRGO/Star2/EEL-2/5yGP	NO	216	85042100								

## Delivery Details

[Delivery must in the units specified for the items as per Price Schedule]

First lot of \_\_\_ in assorted sizes will be delivered within 2 Months from the date of LOA Award. After this period supply will be completed at the rate of \_\_\_ in assorted sized per month

## Confirmation Details

We Confirm The Following :

I) Goods and Services Tax(GST) i.e Integrated GST / (Central GST+ State GST):

The GST is included in our prices quoted in price bid (Central GST+ State GST) for within Maharashtra State/Integrated GST for outside State and we shall not charge any additional amount towards Integrated GST / (Central GST+ State GST), during currency of contract except statutory variation by Central / State Government in normal (full) rate of Integrated GST / (Central GST+ State GST), in case of Integrated GST / (Central GST+ State GST) Rate is increased. In case the Integrated GST / (Central GST+ State GST) is decreased than the rate indicated in the price bid, the benefits of the reduction in the Integrated GST / (Central GST+ State GST) shall be passed on to the Purchaser. The increase in the Integrated GST / (Central GST+ State GST) rate due to increase in turnover during the contractual delivery period shall not be charged to the Purchaser. If the Integrated GST / (Central GST+ State GST) is not payable at present, we shall not charge the same, if it becomes applicable during the currency of contract due to expiry / withdrawal of tax concessions and incentives during the currency of contract except for statutory variation by Central / State Government.

(i) Necessary documentary evidence for the GST claimed by us shall be submitted along with the bills.

(ii) We here by declare that while quoting the price in the Price Bid, we have taken into account the entire credit on inputs available under the GST Act.

Technical Specification Item: 630KVA,11/0.4KV3phDT/ID/CRGO/Star2/EEL-2/5yGP



Maharashtra State Electricity Distribution Company Limited

---

SPECIFICATION NO.MMC: MSC/DB/01 /2018

TECHNICAL SPECIFICATION

For

630KVA,11/0.4KV3phDT/ID/CRGO/Star2/EEL-  
2/5yGP

For

DISTRIBUTION SYSTEM

IN

MSEDCL

## MATERIAL SPECIFICATIONS CELL

**TECHNICAL SPECIFICATIONS OF 630 kVA, THREE PHASE, 11/ 0.433 kV AND 22/0.433 kV COPPER WOUND, CRGO / AMORPHOUS CORE, ONAN DISTRIBUTION TRANSFORMER EEL- II ( STAR-II)**

## INDEX

Clause No.	Contents
1	Scope
2	System Particulars
3	Service Condition
4	Applicable Standards
5	Specific Technical requirement
6	Design & Construction
6.1	Core
6.2	Windings
6.3	Losses
6.4	Insulation Material & Clearances
6.5	Impedance Value
6.6	Tank
6.7	Off Load Taps
7	Efficiency
8	Heat Dissipation
9	Total minimum oil volume
10	Conservator.
11	Breathers.
12	Terminals
13	Bushing and connections
14	Internal Connections
15	Tank base channel/ mounting arrangement
16	Terminal Marking Plate & Rating Plate
17.1	Fittings
17.2	Fasteners
18	Lightning Arrestor
19	Transformer Oil
20	Tests & Inspection
21	Challenge Testing

**TECHNICAL SPECIFICATIONS OF 630 kVA, THREE PHASE, 11/ 0.433 kV AND 22/0.433 kV COPPER WOUND, CRGO/AMORPHOUS CORE, ONAN DISTRIBUTION TRANSFORMER EEL- II ( STAR-II)**

22	Type Tests
23	Drawings
24	Rejection
25	Cleaning & Painting
26	Guaranteed Technical Particulars
27	Testing facilities
28	Submission of Routine Test Certificate
29	Stage Inspection
30	Final inspection
31	Testing of all distribution transformers for losses at 50 % load and 100 % load
32	Random Sample Testing
33	Inspection & Testing of Transformer Oil
34	Quality Assurance
35	Qualifying Requirements
36	Performance Guarantee
37	Cost Data Sheet
38	Schedule
Schedule A	Guaranteed and Other Technical Particulars
Schedule B	Tenderer's experience
Annexure-I	Air Pressure Test
Annexure-II	Unbalance Current Test
Annexure-III	Temperature Rise Test
Annexure -IV	Technical specification for QR Code generation

**1 Scope:-**

- 1.1 This specification covers design, manufacturing, testing and delivery of **630 kva, Three phase, 11/ 0.433kv and 22/0.433kv Copper wound, CRGO/Amorphous core, ONAN Distribution Transformer EEL- II (Star-II)** suitable for 11 kV & 22 kV , 50 Hz, Distribution system.
- 1.2 The equipment offered shall be complete with all parts necessary for their effective and trouble-free operation. Such parts will be deemed to be within the scope of the supply irrespective of whether they are specifically indicated in the commercial order or not.
- 1.3 It is not the intent to specify herein complete details of design and construction. The equipment offered shall conform to the relevant standards and be of high quality, sturdy, robust and of good design and workmanship complete in all respects and capable to perform continuous and satisfactory operations in the actual service conditions at site and shall have sufficiently long life in service as per statutory requirements.
- 1.4 The design and constructional aspects of materials shall not withstanding any anomalies, discrepancies, omissions, in-completeness, etc. in these specifications and will be subject to good engineering practice in conformity with the required quality of the product, and to such tolerances, allowances and requirements for clearances etc. as are necessary by virtue of various stipulations in that respect in the relevant Indian Standards, IEC standards, I.E. Rules, I.E. Act and other statutory provisions.
- 1.5 The Bidder/supplier shall bind himself to abide by these considerations to the entire satisfaction of the purchaser and will be required to adjust such details at no extra cost to the purchaser over and above the tendered rates and prices.
- 1.6 Tolerances:  
The tolerance of guaranteed performance figures shall be as specified in the (Part-I) table 1 of latest issue of IS 2026 **except losses** or relevant International Standard except wherever specified otherwise in this specification.

**2 System Particulars:-**

The transformers shall be suitable for INDOOR installation with following system particulars and they should be suitable for service under fluctuations in supply voltage as permissible under Indian Electricity Rules

<b>2.1</b>	Nominal System Voltage	:	11 kV or 22 kV
<b>2.2</b>	Corresponding Highest System Voltage	:	12 kV or 24 kV
<b>2.3</b>	Rated Basic Insulation Level	:	75 KVp or 125 KVp
<b>2.4</b>	Neutral earthing	:	Solidly earthed
<b>2.5</b>	Frequency	:	50 Hz with $\pm 3$ % tolerance
<b>2.6</b>	Number of Phases	:	3

### **3 SERVICE CONDITIONS:**

**3.1** Equipment supplied against the specification shall be suitable for satisfactory operation under the following tropical conditions:-

i	Max. ambient air temperature	:	50 Deg. C
ii	Max. relative humidity	:	100 %
iii	Max. annual rainfall	:	1450 mm
iv	Max. wind pressure	:	150 kg/sq.m.
v	Max. altitude above mean sea level	:	1000 mtrs.
vi	Isoceraunic level	:	50
vii	Seismic level(Horizontal acceleration)	:	0.3 g.
viii	Climatic Condition		Moderately hot and humid tropical climate conducive to rust and fungus growth.
ix	Reference Ambient Temperature for temperature rise	:	50 Deg C

**3.2** The climatic conditions are prone to wide variations in ambient conditions and hence the equipment shall be of suitable design to work satisfactorily under these conditions.

**3.3** The equipment shall be for use in moderately hot and humid tropical climate conducive to rust and fungus growth.

**3.4** The Distribution Transformer shall be mark with standard mark governed by BIS as per clause 13.4 of IS 1180(Part 1):2014].

**3.5** The Distribution Transformer shall bear Star 2 rating label approved by BEE ( Bureau of Energy Efficiency).

**3.6** The Distribution Transformer shall bear EEL - 2 (star 2 of BEE) ratings label approved by BIS (Bureau of Indian Standard) as per IS 1180 (Part-1):2014 latest amendment.

**3.7** The Bidder/ Manufacturer shall possess the BIS license for offered product.

**TECHNICAL SPECIFICATIONS OF 630 kVA, THREE PHASE, 11/ 0.433 kV AND 22/0.433 kV COPPER WOUND, CRGO/AMORPHOUS CORE, ONAN DISTRIBUTION TRANSFORMER EEL- II ( STAR-II)**
**4 APPLICABLE STANDARDS:-**

- 4.1 The design, manufacture and performance of the equipment shall comply with all currently applicable statutes, regulations and safety codes. Nothing in this specification shall be construed to relieve the bidder off his responsibilities.
- 4.2 The Distribution Transformers shall conform to IS: 1180 (Part 1) : 2014 amended up to date or other International Standards for equal or better performance. Unless otherwise modified in this specification the Distribution Transformers shall comply with the Indian Standard Specification IS 1180 latest.
- 4.3 Unless otherwise specified, the equipment offered shall conform to amended up to date Indian, IEC, British or U.S.A. Standards and in particular, to the following:-
- 4.4 The applicable standards are as follows :

Sr.No.	IS number	IS name
1.	IS:1180(Part-1) : 2014 amended upto date	Oil immersed distribution transformers up to and including 2500 kVA, 33KV.
2.	IS:2026(Part I to IV)	Specification for power transformer
3.	IS:335/2018	New insulating oil- Specification (fifth revision)
4.	IEC 60137 :2017 latest amendment, IS: 7421-1988, IS:3347 (Part-I /Sec-2)-1979, IS:3347 (Part-I /Sec-1)-1982 amended up to date	Bushing
5.	IS 5	Colours for ready mixed paints and enamels.
6.	IS 13730 (Part-27)1996	Specification for particular types of winding wires.
7.	IS: 3073/1974, IS: 3070( Part-II)	Specifications for L.A's
8.	CEA Guidelines August -2008	Manual on transformers
9.	Gazette notification by Ministry of Power dated 16.12.2016	Revised losses of distribution transformers
10.	IS 16585: 2016	Magnetic Material – Specification for for Individual material – Fe-based Amorphous Strip delivered in the Semi- Processed State

- 4.5 In case of conflict arising out due to variations between the applicable standard and the standards specified herein the provisions of this specification should prevail.

**5 Specific Technical requirement:**
**5.1 Standard kVA Ratings:-**

The standard ratings for transformer shall be 630 kVA as per IS 1180 (Part-I):2014

**5.2 Nominal voltage ratings**

- i Primary voltage : 11 kV/ 22 kV
- ii Secondary voltage : 0.433 kV

### 5.2.1 Winding connections:-

- i. H.V. Winding : Delta ( $\Delta$ )
- ii. L.V. Winding : Star (Y)

so as to produce a positive phase displacement of 30 degrees from the primary to the secondary vectors of the same phase. The neutral of the L.V. winding shall be brought out to a separate insulated terminal. The voltage group shall be Dyn-11 (IS 2026 Part I).

### 5.3 Temperature Rise:

- i The temperature rise for top oil over an ambient temperature of 50° C should be 40°C maximum [measured by thermometer in accordance with IS 1180 (Part 1) & IS 2026 (Part 2)].
- ii Temperature rise for winding over an ambient temperature of 50° C should be 45° C maximum [measured by resistance method in accordance with IS 1180 (Part 1) IS 2026 (Part 2)].

### 5.4 No load voltage ratio:-

The no load voltage ratio shall be 11000/433 Volts, 22000/433 Volts.

## 6 Design & construction

- a. The spring washers must be used for fixing core with tie rod.
- b. Core base & bottom Yoke shall be supported with 75 mm X 40 mm X6 mm MS Channel with proper bolting. The core assembly shall be fixed by four locking bolts.
- c. The maximum flux density in any part of the core and yoke at rated voltage and frequency shall be such that the flux density with +12.5 % combined voltage and frequency variation with rated voltage and frequency does not exceed 1.9 Tesla. Flux density should not be more than **1.69 Tesla for CRGO core/1.38 Tesla for Amorphous core** at rated voltage and frequency.
- d. The No load current at rated voltage shall not exceed the percentage as given below :

The no load current of 630 kVA transformer shall not exceed **2%** the full load current and will be measured by energizing the transformer at rated voltage and frequency. Increase of 112.5 percent of rated voltage shall not increase the no load current by **5%** of full load current.( As per IS 1180 (Part1):2014).

### 6.1 Core

- i The Amorphous /CRGO core material shall be used for transformers. The core shall be stacked/ wound type.
  - a) **For Stack core** :- The core shall be of high grade cold rolled grain oriented (C.R.G.O) annealed steel lamination having low loss and good grain properties, coated with hot oil proof insulation, bolted together to the frames firmly to prevent vibration or noise. All core clamping bolts shall be effectively insulated. The complete design of core must ensure

permanency of the core losses with continuous working of the transformers.

**b) For Wound core :-**

The core shall be D type construction of **Amorphous core** or 'C' type construction of high grade cold rolled grain oriented (C.R.G.O.) annealed steel lamination having low loss and good grain properties, coated hot oil proof insulation. The complete design of core must ensure permanency of the core losses with continuous working of the transformers. The core material shall not be brittle in case of CRGO material.

Core clamping for C.R.G.O. Wound core type transformers shall be as follows:

1. Core clamping shall be with top and bottom U- shaped core clamps made of sheet steel clamped.
  2. M.S. core clamps shall be painted with oil-resistant paint.
  3. Suitable provision shall be made in the bottom core clamp / bottom plate of the transformer to arrest movement of the active part.
  4. Core shall be clamped by M16 diameter MS Tie rods.
- ii. The grade of core laminations shall be M3 or better.
- iii. The successful bidder, shall be required to submit the manufacturer's test report showing the Watt Loss per kg and the thickness of the core lamination, to ascertain the quality of Core materials.  
The purchaser reserves the right to get sample of the core material tested at any Government recognized laboratory.
- iv. The transformer core shall not be saturated for any value of V/f ratio to the extent of 112.5% of the rated value of V/f ratio (i.e. 11000/50 or 22000/50) (due to combined effect of voltage and frequency) up to 12.5% without injurious heating at full load conditions and will not get saturated. The bidder shall furnish necessary design data in support of this situation.
- v. **Flux density:-**  
Flux density at rated voltage and frequency should not be more than **1.69 Tesla for CRGO core/1.38 Tesla for Amorphous core**. The maximum flux density in any part of the core and yoke at rated voltage and frequency shall be such that the flux density with +12.5 % combined voltage and frequency variation with rated voltage and frequency does not exceed **1.9 Tesla**.
- vi. Number of steps of stack core shall be as follows

Sr. No.	Rating (kVA)	Number of steps
1	630	Min. 9 standard steps

**vii. Core clamping:**

- a. M.S channel for clamping core shall be 150 mm x 75 mm for 630 kVA transformers.
- b. M.S. Core base support channel shall be 100 mm x 50 mm.
- c. M16 (min) dia, 2 nos High Tensile Bolts for 630 kVA in parallel at each end will be used.
- d. The top yoke channels to be reinforced by adequate size of M.S. flat with thickness not less than 8 mm, at equidistance if holes cutting are one for LT lead so as to avoid bending of channel.
- e. M S channels are to be painted by heat resistant paint.
- f. Core clamping shall be with top and bottom U- shaped core clamps made of sheet steel clamped.
- g. Suitable provision shall be made in the bottom core clamp / bottom plate of the transformer to arrest movement of the active part.

**viii. Tie bolts:**

- a. 8 nos. of tie rods of M16 dia. high tensile steel in vertical formation.
- b. All top and bottom yoke nut bolts, if any, shall be MS and painted with heat and corrosion resistant paint before use.
- c. Drawing of the building of core to be approved before start of work.
- d. The base channels of the core shall not be cut channel.

Note : Only Prime quality ISI marked CRGO core material shall be used in all transformers and it will be confirmed/ checked by inspector at the time of inspection.

**6.2 Winding:-**

The material for winding shall be Copper.

- i. Materials:- Double paper covered Copper conductor shall be used for HV and LV winding for 11 kV & 22 kV with respective class.
- ii. Current Density:- Current density for HV and LV winding should not be more than 2.8 Amp/sq. mm for Copper.
- iii. L.V. Neutral formation shall be at top.
- iv. For stack core winding transformers minimum No of HV coils per phase 4for 11kV class and 6 for 22 kV class and for Wound core type transformers only one HV coils per phase shall be used

**6.3 Losses :**

The total losses (No-load + Load losses at 75 °C ) at 50% of rated load & Total losses at 100% of rated load shall not exceed the maximum total loss values indicated as below ( As per Gazette notification issued by Ministry Of Power on Dated 16.12.2016 the respective losses capacity wise revised).

TABLE – 1

Rating	Impedance ( Percent)	Maximum total losses in watts up to 11 kV Class star -2 (EEL-2)	
		50% Load	100% Load
<b>630</b>	<b>4.5</b>	<b>1745</b>	<b>4850</b>

**Note:- 1) For Transformer having voltage class above 11 kV and up to and including 22 kV, the permissible total loss values shall not exceed by 5 percent of the maximum total loss values mentioned in above table. ( Ref Clause 7.8.1.1.2 of IS 1180: Part- I/2014).**

**Tolerances:**

No positive tolerance shall be allowed on the maximum losses given in the above table for both 50 % & 100 % loading values. In case the actual loss values exceed the above guaranteed values, the transformers shall be rejected at the risk, cost and responsibility of the supplier. The bidder should guarantee individual No load losses without any positive tolerance.

The values guaranteed in G.T.P. for flux density, no load current at rated voltage, no load current at 100 % & 112.5% of rated voltage and no load loss at rated voltage shall be individually meet.

The tolerance on electrical performance excluding losses shall be as given in IS 2026(Part 1).

**6.4 Insulation material & clearances:**

- i** Materials - Makes of Electrical grade insulating craft paper, Press Board, Perma wood/ Haldi wood insulation shall be declared in GTP by the bidder. The test reports for all properties as per relevant I.S. amended up to date shall be submitted during inspection.
- ii** For 630 kVA transformer, minimum Thickness of locking spacers between HV coils – 10mm.
- iii** Minimum Number of Axial wedges between LV and HV winding equispaced around LV – 8 numbers.
- iv** Internal Clearances:
  - a) Radial clearances of LV coil (bare conductor) to core shall be minimum 3.5 mm for 11kV and minimum 4 mm for 22 kV transformers.
  - b) Radial clearance between HV & LV winding shall be minimum 11mm for 11kV and minimum 14mm for 22kV.
  - c) Phase to Phase clearance between HV conductor shall be minimum 10mm for 11kV and minimum 15mm for 22kV
  - d) Minimum end insulation to Earth shall be 25 mm for 11kV and 40 mm for 22KV.
  - e) The electrical clearance between the winding and body of the tank (between inside surface of the tank and outside edge of the windings) should not be less than 30mm and 40 mm for 11kV and 22 kV class transformers respectively.

## 6.5 Impedance Value -

The percentage impedance at 75 ° C. for different ratings shall be as per Table-1 at clause no. 6.3.

## 6.6 Tank

- 6.6.1 The transformer tank shall be made up of prime quality M.S. sheets of Rectangular shape. No other shape will be accepted. The transformer tank shall be of robust construction. All joints of tank and fittings should be oil tight and no bulging shall occur during service. The tank design shall be such that the core and windings can be lifted freely. The tank plates shall be of such strength that the complete transformer when filled with oil may be lifted bodily by means of the lifting lugs provided. Tank inside shall be painted by varnish or oil resistant paint. Top cover plate shall be slightly sloping; approximately 5 to 10 deg. towards HV bushing and edges of cover plate should be bent downwards so as to avoid entry of water through the cover plate gasket. The width of bend plate shall be 25 mm min. The top cover shall have no cut at point of lifting lug. The rectangular tank shall be fabricated by welding at corners.
- 6.6.2 The transformer tank of corrugation is also acceptable, however shape of tank shall be rectangular only. The corrugation sheets thickness shall be of minimum 1.25 mm. Corrugation panel shall be used for cooling. The transformer shall be capable of giving continuous rated output without exceeding the specified temperature rise. Bidder shall submit the detailed calculation sheet along with offer. The safe guard angle frame 50X50X5 mm shall be welded for corrugated side to the tank.
- 6.6.3 In rectangular shape tanks, horizontal or vertical joints in tank side walls and its bottom or top cover will be not allowed. In addition the cover of the main tank shall be provided with an air release plug to enable air trapped within to be released.
- |                                |   |              |
|--------------------------------|---|--------------|
| Side wall thickness            | : | 4 mm. (min.) |
| Top and bottom plate thickness | : | 6 mm. (min.) |
- 6.6.4 For 630 kVA transformers plain tank shall be capable of withstanding a pressure of 80 kPa and a vacuum of 500 mm of mercury. Limiting values of deflection are specified in clause no. 20.4 of technical specification.
- 6.6.5 Reinforced by welded angle 50X75X5 MM for 630 kVA on all the outside walls on the edge of tank to form two equal compartments.
- 6.6.6 When transformer tank without oil is subject to air pressure of 35 KPa above atmospheric pressure for 30 min. Pressure test shall be performed carefully at the time of 1<sup>st</sup> stage inspection only to confirm the adequacy of reinforcement angle and gauge of the tank and certified by E.E. (IW).
- 6.6.7 All welding operations to be carried out by MIG process.( Metal Inert Gas Welding)

- 6.6.8 Lifting lugs: for 630 kVA tank, 4 nos. welded heavy duty lifting lugs shall be provided . The lifting lugs shall be of MS plate of 12mm thickness suitably reinforced by vertical supporting flat of same thickness as of lug welded edgewise below the lug on the side wall, up to reinforcing angle.. They shall be so extended that cutting of bend plate is not required. 2 lifting Lugs for top cover 8 mm thickness shall be provided.
- 6.6.9 Pulling lugs: for 630 kVA tank, 4 nos. of welded heavy duty pulling lugs of MS plate of 8mm thickness shall be provided to pull the transformer horizontally.
- 6.6.10 All bolts / nuts / washers exposed to atmosphere shall be as follows:[Clause no.15.3 of IS 1180(Part 1):2014]
- i. Size 12mm or below—stainless steel.
  - ii. Above 12mm --- steel with suitable finish like electro galvanized with passivation or hot dip galvanized and for Top cover fixing nut bolts of 1/2” diameter (min) with one plain washer shall be used spaced at 4” apart. 6 mm neoprene bonded cork oil resistance gaskets conforming to type B/C IS 4253 Part-II amended up to date will be placed between tank and cover plate.
- 6.6.11 The transformer tank shall be of adequate mechanical strength to withstand positive and negative pressures built up inside the tank while the transformer is in operation.
- 6.6.12 The tank design shall be such that the core and windings can be lifted freely.
- 6.6.13 Plain tank shall be capable of withstanding a pressure of 80kPa for 30 minutes and a vacuum of 500 mm of mercury for 30 minutes (Type Test). The permanent deflection of flat plates shall not exceed the values given in IS 1180(Part 1): 2014 clause no. 21.5.2.1.
- 6.6.14 Thermometer pocket with cap must be located at center of top cover or high side of tank height for true valve of max top oil temperature.
- 6.6.15 Pressure release device or explosion vent shall be placed at top cover of the transformer.
- 6.6.16 QR code laminated P touch labels shall be fixed on transformer tank body below the name plate depicting various technical details such as Name of manufacturer, rating, Serial no, date of manufacturing, A/T No. etc.
- 6.7 Off Load Taps:**
- 6.7.1 The standard tapping ranges, when taps are provided, shall be as follows: Winding tapped : HV  
Number of tap positions 7  
Voltage variations : (+) 5 percent to (-) 10 percent in steps of 2.5 Percent for variation of HV Voltage  
(As per IS 1180 (Part1):2014 Clause 7.7.1).
- 6.7.2 **Tapings are not required for 630 KVA capacity transformers.**
- 6.7.3 Tapping Method: Off circuit tap-changing arrangement shall be either by means of links or by means of an externally-operated switch with mechanical locking device and a position indicator. Arrangement for pad-locking shall be provided. ( As per IS 1180 (Part1):2014 Clause 7.7.2).

6.7.4 Tap changing shall be carried out by means of an externally operated self-position switch and when the transformer is in de-energised condition switch position No.1 shall correspond to the maximum plus tapping. Each tap change shall result in variation of 2.5 % in voltage. Provision shall be made for locking the tapping switch handle in position. Suitable aluminium anodized plate shall be fixed for tap changing switch to know the position number of tap.

6.7.5 The Transformer shall be capable of being operated without danger on any tapping at the rated kVA with voltage variation  $\pm 10\%$  corresponding to the voltage of that tapping.

#### 7.0 Efficiency:

The efficiency is the ratio of output in KW to the input in KW.

$$\text{Efficiency} = \frac{(\text{Input in KW} - \text{Total Losses in KW})}{\text{Input in KW}}$$

Total losses comprise of No-load loss and Load loss at 75 °C.

#### 8.0 Heat Dissipation:

- a) Heat dissipation by tank walls excluding top and bottom should be 500 W/sq.mtr.
- b) Heat dissipation by fins type radiator 1.25 mm thick will be worked out on the basis of manufacturers data sheet. The bidder shall submit the calculation sheet with the offer or the offer shall stand rejected.
- c) Radiators shall be welded on tank wall in a such a way there should not oil leakage.
- d) Radiators shall be provided on both HV and LV bushing side of the transformer tank wall and shall be of fin type. They should be fixed at right angle to the sides and not diagonally. The size of the radiator shall be such that it covers at least 50% of the bottom yoke, full core and complete top yoke.
- e) The transformer shall be capable of giving continuous rated output without exceeding the specified temperature rise. Bidder shall submit the detailed calculation sheet along with offer.
- f) Heat dissipation by Corrugation panel 1.25 mm thick will be worked out on the basis of manufacturer's data sheet. The bidder shall submit the calculation sheet with the offer or the offer shall stand rejected.

### 9.0 Total Minimum Oil Volume :

The firm should maintain the minimum oil volume in all supplied transformers as mentioned below or oil up to mark indicator level whichever is more.

KVA rating	Oil in liters (exclusive of oil absorbed in core & coil assembly)	
	Voltage rating 11/0.433 kV	Voltage rating 22/0.433 kV
<b>630</b>	<b>750</b>	<b>800</b>

### 10.0 Conservator:

- The total volume of conservator shall be such as to contain 10% of total quantity of oil. Normally 3% quantity of the total oil will be contained in the conservator. Dimension of the conservator shall be indicated on the General Arrangement Drawing. The capacity of the conservator tank shall be designed keeping in view the total quantity of oil and its contraction and expansion due to the temperature variations.
- Oil level indicator shall be provided on the side which will be with fully covered detachable flange with single gasket and tightened with MS nut-bolt. Level indication by colour shall not be accepted.
- The inside diameter of the pipe connecting the conservator to the main tank shall be within 20 to 32 mm and it should be project into the conservator in such way that its end is approximately 20 mm above the total of the conservator so as to create a sump for collection of impurities. The minimum oil level (corresponding to (-) 5 deg.) should be above the sump level & filling hole (32mm dia) with cover.
- There shall be minimum -5deg, normal 30deg and maximum 90deg marking on the oil gauge indicator of the conservator.
- The pipe of conservator tank shall have slopping flap so that the oil falling from the pipe shall not fall on the active job and shall fall on the side wall only.
- The conservator tank shall be provided with drain plug and a filling hole (30 mm) with cover

### 11.0 Breather:

- The material used for breather shall be only of Polypropylene
- The dehydrating Silica Gel breather shall be provided. The volume of breather shall be suitable for 1kg silica gel confirming to IS 3401 for 630 kVA transformers.

Makes of the breather shall be subject to purchaser's approval. The make and design of breather shall be subject to approval of C.E. (T&QC).

## 12.0 Bushing Terminals:

- a. The Palm type terminal connector of adequate capacity shall be connected to L.V side suitable to connect it to the Bus extension
- b. On H.V. side the bimetallic connector to be provided
- c. The rating of Brass Rod for H.V Bushing & Copper Rods for L.V Bushing shall be as per relevant IS for different capacity of Transformer. [Following (b) and (c) are indicative and shall be confirmed with relevant IS]
- d. HV Bushing terminal shall be 12 mm. diameter Brass rods with Bimetallic terminal connectors provided with necessary nuts, check-nuts and plain thick tinned washers.
- e. LV Bushing terminal shall be Tinned Copper Rods with M20 diameter for 630kVA, transformers. For LT extension Bimetallic terminal connectors suitable to cable box shall be provided with suitable necessary nuts, check- nuts and plain thick tinned washers.

## 13.0 Bushings & Connections:

- 13.1 For Indoor type transformers HV and LV Bushings of Porcelain/ Epoxy of appropriate voltage and current ratings shall be mounted on opposite side of transformer tank in HV and LV cable box The high voltage bushings (3nos.) shall be provided with R-Y-B colour coding marking & shall conform to IEC 60137 :2017 latest amendment,. The low voltage bushings shall conform to IS 7421. Alternatively, the low voltage cable box shall be made suitable for adoption of single core XLPE cables. The dimensions shall conform to IS 1180(Part 1): 2014 clause no. 10.1.5.
- 13.2 The LV bushings shall be made in two parts. The outer bushing shall be of porcelain. The dimensions of the outer bushing shall confirm to the relevant Part/Section of IS 3347 depending on the voltage class. The internal bushing shall be of either porcelain or tough insulating material, like epoxy and shall have embedded stem Metal portion of the internal HV and LV bushing inside the tank shall remain dipped in oil in all operating conditions.
- 13.3 The epoxy type HV and LV Bushings with suitable terminals shall be used as per relevant standards.
- 13.4 Gaskets shall be made of Nitrile rubber or synthetic rubberized cork resistant to hot transformer oil shall be provided to HV and LV Bushing.
- 13.5 For 11 kV class 12 kV bushing, & for 22 kV class 24 kV bushing shall be used and for 433 volts 1.0 kV bushing shall be used. Bushings of the same voltage class shall be interchangeable. Bushings with plain shed shall be as per relevant IS:3347 amended up to date. HV bushings & LV bushings shall be mounted on the sides of the transformer tank.
- 13.6 Supporting clamps for LT cable should be provided to avoid the weight of cable on the Bushing.
- 13.7 The minimum creepage distance for both HV & LV Bushings shall not be less than 25 mm per kV.

**TECHNICAL SPECIFICATIONS OF 630 kVA, THREE PHASE, 11/ 0.433 kV AND 22/0.433 kV COPPER WOUND, CRGO/AMORPHOUS CORE, ONAN DISTRIBUTION TRANSFORMER EEL- II ( STAR-II)**

13.8 Rectangular shaped, M.S. Sheet thickness 2 mm, weather, vermin and dust proof HV/LV Cable boxes shall be fitted on opposite sides of the tank of transformer. (Indoor application) as per details given below.

**HV (11kV or 22kV) cable box:-** Air filled cable box suitable for 3 core XLPE aluminum cables up to 300 sq.mm. & glands suitable for above cables.

**LV 0.433 kV Cable Box:-**

Air filled Cable Box suitable to single Core 400 sq.mm. XLPE Aluminum cable i.e. 3 cable run/Phase & 1 cable run for neutral for 630 kVA distribution transformer.

For 630 kVA dist transformer, LV Bushings shall be provided with suitable Aluminium Busbar Extensions to take off circuits with necessary nuts and bolts with resin cast support insulators. Separate Bushing for Earthing connection shall be provided to cable box with suitable wire mesh. The Aluminium non-magnetic gland plates shall be provided.

13.09. Minimum external clearances for Indoor Bushing terminals in HV and LV Cable Box.  
(as per IS 1180: part I 2014 clause no. 11.1 table no 11.)

		<u>11 kV</u>	<u>22 kV</u>
HV	Ph to Ph	130 mm	240 mm
	Ph to E	80 mm	140 mm
LV	Ph-to-Ph	25 mm.	25 mm
	Ph to E	20 mm.	20 mm

#### 14.0 Internal connections:

##### 14.1 H.V. Winding :

- i. Leads should be taken through Kraft paper / Creep paper / Equivalent tubes.
- ii. Inter coil spacers between HV sections by dovetailed paper block min.8mm to avoid displacement of coil during transportation.
- iii. The copper strip/foil used for core earthing at two locations shall be tinned copper.
- v In case of H.V. winding all jumpers from winding to bushing shall have cross section larger than winding conductor.
- v. Inter coil connection shall be by crimping and brazing.
- vi. In case of Copper Winding Delta joints shall be with crimping and Brazing only.
- vii. Lead from delta joint shall be connected to bushing rod by brazing only.

##### 14.2 L.V. Winding :

- i. For Copper windings crimping & silver brazing alloy shall be used.
- ii. L.T. Star point shall be formed of Copper flat of sufficient length. Lead from winding shall be connected to the flat by crimping and brazing.
- iii. Firm connections of L.T. winding to bushing shall be made of adequate size of 'L' shaped flat. Connection of L.T. Coil lead to 'L' shape flat shall be by crimping and brazing. Alternatively 'L' shape lug of adequate capacity effectively crimped shall be acceptable.
- iv. 'L' shape flat/lug shall be clamped to L.V. Bushing metal part by using nut, lock-nut and washers.

#### 15.0 Tank base channel / Mounting Arrangement:

The under-base of the transformer shall be provided as per clause 14.2 of IS 1180(Part1):2014

#### 16.0 Terminal Marking Plates and Rating Plate:

- a) All Transformer HV terminals shall be provided terminal marking plated to Tank. Each terminal, including with neutral, shall be distinctly marked on both primary & secondary in accordance with the connection diagram fixed upon the transformer which shall conformed to latest IS-2026 (part- IV).
- b) Each Transformer shall be provided with rating plate having marking as per IS 1180 (part-1):2014 clause no 13 clearly indicating max. total losses at 50% rated load in watts and maximum total losses at 100% rated load in watts
- c) Rating & terminal marking plates shall be combined into one plate and shall be mark with standard mark Govern by the provisions of the BIS act 1986.
- d) Terminals shall be provided with terminal marking plates. The transformer shall be provided with riveted rating plate of minimum 18 SWG aluminum anodized.

**TECHNICAL SPECIFICATIONS OF 630 kVA, THREE PHASE, 11/ 0.433 kV AND 22/0.433 kV COPPER WOUND, CRGO/AMORPHOUS CORE, ONAN DISTRIBUTION TRANSFORMER EEL- II ( STAR-II)**

material sheet in a visible position. The entries of the rating plate shall be in indelibly marked (i.e. by etching, engraving or stamping).

- e) Marking as `M.S.E.D.C.L'S and `Sr. No.' of transformer shall be engraved on transformer main tank below L.T. bushings.
- f) The name of the company, order No., capacity, month and year of manufacturing shall be engraved on separate plate which shall be firmly welded to main tank and shall form integral part of the tank.
- g) The distribution transformer may also be marked with the Standard Mark. The use of Standard Mark is governed by the provisions of the Bureau of Indian Standards Act, 1986 and the Rules Regulations made thereunder.

Besides other particulars, following details shall also be given on the name plate.

- ISI Mark.
- BEE Energy Efficiency Star label
- BIS Energy Efficiency level.
- Order No. – Month & year.
- Sr. No. of transformer.
- Date of manufacturing – Month & year.
- Date of expiry of guarantee period – month & year.
- Maximum guaranteed 50% load loss & 100 % load loss figures.
- Name and full address of the manufacturer.
- Capacity.
- Rating.

(All details on the rating and diagram plate shall be indelibly marked i.e. by engraving or stamping or etching).

### 17.1 Fittings:

The following standard fittings shall be provided.

1	Rating and diagram plate	1 no.
2	Earthing terminals with lugs.	2 nos.
3	Lifting lugs	6 nos. ( 4 nos for tank and 2 nos for top plate of the transformer )
4	Oil filling hole with cap (on conservator)	1 no
5	Drain valve – 32mm for all T/Fs ( It shall be covered with metallic box spot welded to tank) IS554	1 no
6	Conservator with drain plug.	1 no

**TECHNICAL SPECIFICATIONS OF 630 kVA, THREE PHASE, 11/ 0.433 kV AND 22/0.433 kV COPPER WOUND, CRGO/AMORPHOUS CORE, ONAN DISTRIBUTION TRANSFORMER EEL- II ( STAR-II)**

7	The pipe connecting the conservator to the main tank.	1 no
8	Thermometer pocket with cap	1 no
9	Air release device.	1 no
10	Explosion vent with diaphragm	1 no
11	Silica gel breather 1kg kg	1 no
12	Platform mounting channel ( with hole suitable for axle of rollers)	2 nos
13	Oil level gauge indicating 3 positions of oil marked as below :	1no
	Minimum (-) 5 deg.C.	
	Normal 30 deg.C	
	Maximum 98 deg.C.	
14	HT & LT bushing and terminal connectors	3 nos. of HT bushing and 4 nos. of LT bushing shall be provided with bimetallic T –type terminal connector & necessary nuts, check- nuts and plain thick tinned washer of adequate capacity shall be connected to L.V & HV side
15	Radiators	As per Cl. No. 8 of tech spec.
16	Pulling lugs	4 nos
17	Rollers	4 nos
18	Five year guarantee plate	1 no.
19	Filter valve ( 32 mm dia)	1 no.
20	Anti-theft stainless steel fasteners with breakaway nut at top cover	4 nos.
21	QR Code Label	1Nos

Any other fitting necessary for satisfactory performance.

**17.2 Fasteners.**

- All bolts, studs, screw threads, pipe threads, bolt heads and nuts shall comply with the appropriate Indian standards for metric threads or the technical equivalent.
- Bolts or studs shall not be less than 6 mm in diameter except when used for small wiring terminals.
- All nuts and pins shall be adequately locked.
- Wherever possible bolts shall be fitted in such a manner that in the event of failure of locking resulting in the nuts working loose and falling off, the bolt

**TECHNICAL SPECIFICATIONS OF 630 kVA, THREE PHASE, 11/ 0.433 kV AND 22/0.433 kV COPPER WOUND, CRGO/AMORPHOUS CORE, ONAN DISTRIBUTION TRANSFORMER EEL- II ( STAR-II)**

will remain in position.

- All ferrous bolts, nuts and washers placed in INDOOR positions shall be treated to prevent corrosion by hot dip galvanizing except high tensile steel bolts and spring washers, which shall be Electro, galvanized. Appropriate precautions shall be taken to prevent electrolytic action between dissimilar materials.
- Each bolt or stud shall project at least one thread but not more than three threads through the nut, except when otherwise approved for terminal board studs or relay stems. If bolts are provided at inaccessible places for ordinary spanners, special spanners shall be provided.
- The length of screwed portion of the bolts shall be such that no screw thread may form part of a sheer plane between members.
- Taper washers may be provided where necessary. Protective washers of suitable material shall be provided front and back of the securing screws.
- LT side should be of Pad type terminal.

### 18.0 Lightning Arrestors (only for outdoor type transformers)

The Lightning Arrestors (Disconnecter type) of high surge capacity of 9 kV( Vrms), 5 kA( 8/20 micro wave shape) for 11 kV class transformers and 18 kV( Vrms), 5 kA ( 8/20 micro wave shape) for 22 kV class transformers, conforming to IS: 3070/1993 shall be mounted on the HV bushings of transformer, clamped securely to the tank, to protect the transformer and associated line equipment from the occasional high voltage surges resulting from lighting or switching operations. The earthing terminal of the lightning arrestors shall be grounded separately.

Random sample of LA shall be destructively tested by breaking the LA to confirm availability of inside component.

### 19.0 Transformer Oil

Transformer oil to be used in all the Distribution transformers shall comply with the requirements of latest IS 335/2018 amended up to date thereof.

The **Unused Mineral Insulating Oils (type II)** are obtained by distillation and refining of crude petroleum as required to meet the properties specified below.

Sr. No.	Property	Test Method	Permissible Values
<b>A. Function</b>			
1.	Viscosity at 40°C	IS : 1448 ( Part 25 )	15 mm <sup>2</sup> /s, Max.
2.	Viscosity at 0°C	IS : 1448 ( Part 25 )	1800 mm <sup>2</sup> /s, Max.
3.	Pour – Point	IS : 1448 ( Part 10/Sec2 )	- 10°C, Max. , to be based on LCSET
4.	Water content	IEC 60814	30 mg/kg , Max. / 40 mg/kg, Max.
5.	Breakdown voltage	IS : 6792	30kV / 70kV, Min.
6.	Density at 20°C	IS : 1448 ( Part 16 )	0.895 g / ml. Max.
7.	DDF at 90°C	IS : 16086	0.005, Max.
8.	Particle content	IS : 13236	No general requirement.
<b>B. Refining / stability</b>			
9.	Appearance	----	Clear, free from sediment and suspended matter.
10.	Acidity	IEC 62021-1	0.01 mg.KOH / g, Max.

**TECHNICAL SPECIFICATIONS OF 630 kVA, THREE PHASE, 11/ 0.433 kV AND 22/0.433 kV COPPER WOUND, CRGO/AMORPHOUS CORE, ONAN DISTRIBUTION TRANSFORMER EEL- II ( STAR-II)**

11.	Interfacial tension	ASTM D 971	No general requirement.
12.	Total sulphur content	ISO 14596 or ASTM D 4294	No general requirement.
13.	Corrosive sulphur	DIN 51353	Not corrosive.
14.	Potentially corrosive sulphur	IS : 16310	Not corrosive.
15.	DBDS	IS : 16497 ( Part 1 )	Not detectable ( <5mg/kg)
16.	Inhibitors according to IS : 13631 / IEC : 60666	IS : 13631	(U) Uninhibited oil: not detectable (<0.01%)
			(T) Trace inhibited oil : <0.08%
			(I) Inhibited oils : 0.08%-0.40%
17.	Metal passivator additives according to IS : 13631 / IEC : 60666	IS : 13631	Not detectable ( <5mg/kg)
18.	Other additives	---	See 7
19.	2-Furfural and related compounds content	IS : 15668	Not detectable ( <5mg/kg) For each individual compound.
<b>C. Performance</b>			
20.	Oxidation stability	IS : 15668(Method C) (U) Uninhibited oil : 164h (T) Trace inhibited oil :332h (I) Inhibited oil :500h	For oils with other antioxidant additives and metal passivator.
a)	• Total acidity,9	1.9.4 of IS : 12422	1.2mg KOH/g, Max.
b)	• Sludge,9	1.9.1 of IS : 12422	0.8%, Max.
c)	• DDF at 90°C. 9	1.9.6 of IS : 12422	0.500, Max
21.	Gassing tendency	IEC : 60628, Method A	No general requirement.
22.	ECT	--	No general requirement.
<b>D. Health, Safety and Environment (HSE)</b>			
23.	Flash point	IS : 1448 (Part 21)	135°C, Min.
24.	PCA content	IP : 346	3%, Max.
25.	PCB content	IS : 16082	Not detectable ( <2mg/kg)

Refer Note to table no. 2 of IS: 335; 2018

**20.0 Test and Inspection:-** All routine, type and special tests as described in Clause 21.2 to 21.4 of IS 1180 (Part 1):2014 shall be performed as per relevant parts of IS 2026. Pressure and oil leakage test shall be conducted as per Clause 21.5 of IS 1180 (Part1):2014.

**20.1 Routine Tests (to be conducted on all units):-** The following shall constitute the routine tests:

- Measurement of winding resistance [ IS 2026 (Part 1)].
- Measurement of voltage ratio and check of phase displacement [ IS 2026 (Part 1)].
- Measurement of short circuit impedance ( principal tapping, when applicable) and load loss at 50 percent and 100 percent load [ IS 2026 (Part 1)].
- Measurement of no load loss and current [ IS 2026 (Part 1)].
- Measurement of insulation resistance [ IS 2026 (Part 1)].

**TECHNICAL SPECIFICATIONS OF 630 kVA, THREE PHASE, 11/ 0.433 kV AND 22/0.433 kV COPPER WOUND, CRGO/AMORPHOUS CORE, ONAN DISTRIBUTION TRANSFORMER EEL- II ( STAR-II)**

- f) Induced over-voltage withstand test [ IS 2026 (Part 3)].
- g) Separate-source voltage withstand test [ IS 2026 (Part 3)].
- h) Pressure test
- i) Oil leakage test

All the above routine tests shall be carried out by the Inspecting Officer on the 10% quantity of the lot offered for inspection at the factory premises

**20.2 Type Tests (to be conducted on one unit):-** The following shall constitute the type tests:

- a) Lightning impulse test [ IS 2026 (Part 3)].
- b) Temperature-rise test [ IS 2026 (Part 2)].  
Note – Maximum measured total loss ( No load at rated excitation + load loss at maximum current tap converted to 75 Deg.Celcius reference temperature) at 100 percent loading shall be supplied during temperature rise test.
- c) Short-circuit withstand test [ IS 2026 (Part 5)]. ( above 200 kVA)
- d) Pressure test.

20.2.1 The Type Tests on offered rating transformer as per Clause 20. 2 above shall be successfully carried out at laboratories accredited by National Accreditation Board for Testing and Calibration Laboratories (NABL) in accordance with IS 1180 (Part 1):2014 as amended from time to time and technical specifications, within the last 5 (five) years prior to the date of offer.

20.2.2 The bidder shall submit the type test report of transformer along with his offer

**20.3 Special Tests (to be conducted on one unit):-** The following shall constitute the special tests which shall be carried out by mutual agreement between the user and the supplier.

- a) Determination of sound levels [ IS 2026 (Part 10)].
- b) Short-circuit withstand test [ IS 2026 (Part 5)]. ( above 200 kVA).  
NOTE :- Routine tests before and after short circuit test shall be conducted as per IS 2026 ( Part 1)
- c) No load current 112.5 percent voltage [refer clause 7.9.2 of IS 1180(Part 1): 2014].

**20.4 Pressure and Oil leakage Test :-**

**20.4.1 Pressure Test ( Type Test) :** For non-sealed and sealed type transformers, the transformer tank subjected to air pressure of 80 kPa for 30 min and vacuum of 500 mm of mercury for 30 min. The permanent deflection of flat plate, after pressure/vacuum has been released, shall not exceed the values given below.

Length of Plate	Deflection
Up to 750 mm	5.0 mm
751 mm to 1250 mm	6.5 mm
1251 to 1750 mm	8.0 mm

**TECHNICAL SPECIFICATIONS OF 630 kVA, THREE PHASE, 11/ 0.433 kV AND 22/0.433 kV COPPER WOUND, CRGO/AMORPHOUS CORE, ONAN DISTRIBUTION TRANSFORMER EEL- II ( STAR-II)**

Above 1751 mm	9.0 mm
---------------	--------

**20.4.2. Pressure Test ( Routine Test) :**

**a) Plain tanks :** The transformer tank with welded / bolted cover shall be tested at a pressure of 35 kPa above atmospheric pressure maintained inside the tank for 10 min. There should be no leakage at any point .

**b) Corrugated tanks :** The corrugated transformer tank shall be tested for air pressure of 15 kPa above atmospheric pressure maintained inside the tank for 10 min. There should be no leakage at any point .

**2043 Oil leakage Test ( routine Test) :** The assembled transformer for non-sealed and sealed type with all fittings including bushing in position shall be tested at a pressure equivalent to twice the normal head measured at the base of the tank for 8 h. There should be no leakage at any point. Tank with corrugations shall be tested for oil leakage test a pressure of 15 kPa measured at the top of the tank for 6 h. There should be no leakage at any point.

All the routine tests shall be conducted in the suppliers' laboratory at their own cost.

- i) Heat run test shall be arranged free of cost on the unit selected from the 1<sup>st</sup> lot by Executive Engineer/Authorized Representative.
- ii) The calculations to confirm the thermal ability IS or equivalent International Standard shall be submitted to Executive Engineer (IW).

**21.0 Challenge Testing:**

The manufacturer can also request challenge testing for any test based on specification and losses. The challenger would request for testing with testing fees. The challenge test fees are proposed at least three times the cost of testing. This is likely to deter unnecessary challenges. The challenger would have the opportunity to select the sample from the store and any such challenge should be made within the guarantee period. The party challenged, challenger and the utility could witness the challenge testing.

The challenge testing would cover following tests:

1. Measurement of magnetizing current.
2. No load losses test.
3. Load losses test (at 50 % loading or as per routine test).
4. Temperature rise test.

The challenge test could be conducted at NABL Laboratory, like ERDA and CPRI. If the values are within the limits the products gets confirmed else not confirmed. No positive tolerances in losses is permitted. If the product is not confirmed the manufacturer would pay the challenge fee and challenger would get the fee

**TECHNICAL SPECIFICATIONS OF 630 kVA, THREE PHASE, 11/ 0.433 kV AND 22/0.433 kV COPPER WOUND, CRGO/AMORPHOUS CORE, ONAN DISTRIBUTION TRANSFORMER EEL- II ( STAR-II)**

refunded.

However as a redressal system the challenger would be allow to ask for fresh testing of two or more samples from the store and the same be tested in NABL Laboratory in presence of party challenge, challenger and the utility.

If any one of the above sample does not confirm the test, then the product is said to have failed the test. In such cases the manufacturer will be declared as unsuccessful manufacturer for the said product with wide publicity and would not allow to complete in tenders of the MSEDCL for the period of three years and heavy penalty would be imposed.

## **22.0 Type Tests**

**22.1** The Type Tests as per Clause 20.2 above shall be successfully carried out on offered rating distribution transformer at laboratories accredited by National Accreditation Board for Testing and Calibration Laboratories (NABL) in accordance with IS 1180(Part 1):2014 as amended from time to time and technical specifications, within the last 5 (five) years prior to the date of offer.

**22.2** The type test reports of offered rating distribution transformer the should be submitted alongwith the offer and successful bidder should get approved from the Chief Engineer (T & QC) before commencement of supply.

**22.3 In case of any of the following, the offer will not be considered for evaluation only.**

- i) If above tests are carried out beyond 5 years
- ii) Impulse Voltage Withstand test ,Dynamic Short Circuit test, Temperature rise Test & Pressure Test carried out not from NABL approved Laboratory.
- iii) If there is any change in the design/ type of old type tested transformers to be offered against this tender technical specification.

**22.4** In respect of the successful bidder, the purchaser reserves the right to demand repetition of some or all the type tests in presence of the purchaser's representative. In case the unit fails in the type tests, the complete supply shall be rejected. The bidders are therefore requested to quote unit rates for carrying out each type test, which however, will not be considered for evaluation of the offer.

## **23.0 Drawings & Calculation sheet:-**

**23.1** A set of following drawings with all dimensions shall be submitted by the Bidder along with the offer:

- i. General Dimensional drawing.
- ii. Rating & Diagram Plate Drawing.
- iii. Internal Construction Drawing
- iv. Technical Detail drawing.
- v. Core Assembly drawing
- vi. HV& LV Bushings Assembly drawing
- ix. Creepage distances distance drawing of HV& LV Bushing

**TECHNICAL SPECIFICATIONS OF 630 kVA, THREE PHASE, 11/ 0.433 kV AND 22/0.433 kV COPPER WOUND, CRGO/AMORPHOUS CORE, ONAN DISTRIBUTION TRANSFORMER EEL- II ( STAR-II)**

- 
- x. Silica gel Breather drawing.
  - xi. BE star label drawing
  - xii. HV & LV cable box drawing
  - vii. Calculation sheet for flux density
  - xi. Heat dissipation
  - xii. Oil absorption
  - xiii. Thermal time constant.
- 23.2** The drawings shall be of A-3 (420 x 297 mm) size only. The bidder should also supply along with his offer the pamphlets/literatures etc. for fittings /accessories.
- 23.3** The bidder should not change design once offered as per A/T, Approved drawings and Type Test Reports.
- 23.4** The successful Bidders shall submit complete set of Drawings (as listed in Cl.No.23.1) of transformer in triplicate indicating dimensions to CE (T & QC) for approval and get approved it before offering 1st stage inspection.
- 24.0 Rejection :-**
- 24.1** Apart from rejection due to failure of the transformer to meet the specified test requirements the transformer shall be liable for rejection on any one of the following reasons.
- i. Maximum load losses at 50 % load & 100% Load loss exceeds the specified values mentioned in Cl. No.6.3 above.
  - ii. Impedance voltage value exceeds the Guaranteed value plus tolerances as mentioned at Cl.No.6.5 above.
  - iii. Type tests are not carried out as per clause no. 22.0 of the specification.
  - iv. Drawings are not submitted as per clause no. 23.0 of the specification.
  - v. GTP not submitted as per clause no. 26.0 of the specification.
  - vi. Heat dissipation calculation sheet are not submitted as per clause no.8.0 of the specification.
- 25.0 Cleaning and Painting.**
- i. The external surfaces shall be painted one coat of epoxy primer followed by two coats of polyurethane (finish coat) for (outside) and Inside of the tank shall be painted with hot oil resistant paint/varnish with one coat with dry film thickness as mentioned in Table 12, clause 15.5 of IS 1180(Part 1):2014.
  - ii. The certificate shall be produce by the manufacturer if seven tank facilities are availed from the other vendor about availability of the adequate size of tank for treatment.
  - ii. The test of measurement of paint thickness shall be carried out cross hatch test, chemical test and other as per IS 13871:1993
  - iv. The surface of the tank shall be properly pre-treated / phosphated in a seven tank process before painting and the shade of paint shall be **Aircraft Blue** colour ( shade No. 108 as per IS 5) with minimum 40 micron thickness.
  - v. The seven tank process facility shall be enhance to ensure proper quality for INDOOR application.
-

**TECHNICAL SPECIFICATIONS OF 630 kVA, THREE PHASE, 11/ 0.433 kV AND 22/0.433 kV COPPER WOUND, CRGO/AMORPHOUS CORE, ONAN DISTRIBUTION TRANSFORMER EEL- II ( STAR-II)**

- vi. The month and year of supply shall be painted in red bold **Marathi** lettering at two places, one on conservator and other at sum conspicuous place on the transformer which shall be clearly visible from the ground.

**26.0 Guaranteed & Technical Particulars:**

The bidder should fill up all the details in GTP parameter list, the statement such as -as per drawings enclosed, -as per MSEDCL's requirement -as per IS etc. shall be considered as details are not furnished and such offers shall liable for rejection.

**27.0 Testing facility**

The bidder should have adequate testing facility for all routine and acceptance tests and also arrangement for measurement of losses, resistance, etc. details of which will be enumerated in the tender.

**28.0 Submission Routine Test Certificate**

a. The successful bidder shall submit the routine test certificate along with documentary evidence for having paid the Excise Duty for the following raw materials viz. Oil, Aluminum, copper for conductors, insulating materials, core materials, bushings at the time of routine testing of the fully assembled transformer

b. Instruction and operation Manual

The successful bidder shall be required to submit 5 copies of instruction and Operation manual for each lot of 100 Transformers (or part thereof) supplied. This instruction manual should give complete details about the pre-commissioning tests/checks and the details of preventive maintenance etc.

**29.0 Stage Inspection:-**

1. After receipt of LOA, Supplier shall give 15 days' advance intimation to the Chief Engineer (MMD) to organize stage inspection.
2. After receipt of intimation from successful bidder, Chief Engineer (MMD) will depute MSEDCL's representative to visit factory of bidder for Stage Inspection.
3. Activities below will be carried out during Stage Inspection:
  - (a) Verification of available raw material stock & its quality.
  - (b) Verification of assembly of core, windings and other core materials.
  - (c) Verification of Raw materials such as core stamping, winding conductor, oil etc. Bidder shall use these materials manufactured/supplied by the standard manufacturers and furnish the manufacturer's test certificates, proof of purchase from those manufacturers, documentary evidence for having paid the excise duty for the information of the department.
  - (d) Verification of Performance certificate issued by MSEDCL for earlier transformers supplied by bidder and document of compliance done by manufacturer against failure of supplied transformers in previous tenders of MSEDCL, if any.
  - (e) Verification of original type tests reports, Drawings & GTP, if required.
4. After satisfactory inspection, MSEDCL's representative will give clearance to the bidder/manufacturer for further process.
5. MSEDCL's representative may visit factory at any stage of manufacturing process to verify effective use of inspected raw material. The successful bidder shall grant free access to the MSEDCL's representatives at a reasonable time when the work is in progress.

**TECHNICAL SPECIFICATIONS OF 630 kVA, THREE PHASE, 11/ 0.433 kV AND 22/0.433 kV COPPER WOUND, CRGO/AMORPHOUS CORE, ONAN DISTRIBUTION TRANSFORMER EEL- II ( STAR-II)**

**30.0 Final Inspection:**

1. After completion of manufacturing process of all quantity (Lot) as per MSEDCL's clearance letter, Supplier shall give intimation to the Chief Engineer (MMD) to organize final inspection.
2. After receipt of intimation from successful bidder, Chief Engineer (MMD) will depute MSEDCL's representative to visit factory of bidder for final Inspection.

Activities below will be carried out during final Inspection:

- (a) Visual inspection of outer side, design, dimensions, color, name plate etc. of all (100%) ready transformers from offered lot
  - (b) After visual inspection, Inspector will select 10% quantity of transformers at random from offered and visually inspected lot.
  - (c) 10 % of the transformers offered will be tested without opening the transformer for all Routine tests as per MSEDCL's technical specifications & related IS. Heat Run Test will have to be carried out on one transformer having maximum total Losses at 100% load.
  - (d) Out of balance 90% distribution transformers, one transformer shall be opened and all design technical parameters should be checked as per approved GTP, approved drawings and technical specifications.
  - (e) If any technical parameters are found deviating from the approved GTP, approved drawings & technical specifications during final inspection, whole lot shall be reoffered for final inspection after rectification.
3. After satisfactory final inspection, MSEDCL's representative will give clearance to the bidder/manufacturer for dispatch to allotted store.

**31. Testing of all Distribution Transformers for total losses at 50% load and 100% load at MSEDCL stores:**

After receipt of transformers at stores centers, all distribution transformers from the lot will be tested for total Losses at 50% load and 100% load at all stores by MSEDCL as well as by a third party NABL lab like ERDA, etc. Supplier has liberty to be present at the time of testing.

**32.0 Random Sample Testing (RST)**

- 32.1 The bidder should intimate to Chief Engineer (MMD) of completion of dispatches of whole lot of Distribution Transformers to stores against this tender.
- 32.2 Chief Engineer (MMD), M.S.E.D.C.L will select the stores for Random Sample Testing (RST) and depute Executive Engineer (Testing) to carry out RST of the lot.
- 32.3 Advance intimation of 15 days will be given to supplier for joint inspection.
- 32.4 The date of RST will not be altered to the convenience or request of supplier. If supplier's representative fails to attend on the date fixed for RST, the RST will be carried out in his absence and results of RST will be binding on supplier. In case the selected transformer fails in any of the tests, complete lot of transformers will be rejected.
- 32.5 Activities below will be carried out by EE (Testing) during Random Sample Testing: Visual inspection of design, dimensions, color, name plate, radiator, bushings, LAs, Conservator tank, breather etc. of all (100%) transformers from supplied lot.
- 32.6 EE (Testing) will select one transformer at random from the lot of transformers already tested for total Losses at 50% load and 100% load which shall be opened and all design technical

**TECHNICAL SPECIFICATIONS OF 630 kVA, THREE PHASE, 11/ 0.433 kV AND 22/0.433 kV COPPER WOUND, CRGO/AMORPHOUS CORE, ONAN DISTRIBUTION TRANSFORMER EEL- II ( STAR-II)**

parameters shall check as per approved GTP, approved drawings and technical specifications. That Selected transformer for random testing shall be tested for all routine testing before opening.

- 32.7** If any technical parameters are found deviating from the approved GTP, approved drawings & technical specifications during Random Sample Testing, whole lot shall be rejected.

**33.0 Inspection & Testing of Transformer Oil:**

The tenderer shall make arrangements for testing of transformer oil to be used in the transformers and testing will be done in presence of purchaser's representative.

To ascertain the quality of transformer oil, original manufacturer's test report should be furnished to EE (Testing) at the time of factory inspection for acceptance of the lot.

**34.0 Quality Assurance**

- 34.1 The bidder shall invariably furnish following information along with the offer failing to which the offer will be rejected.

- 34.2 Certificates of following materials.

- i. Copper conductor
- ii. Transformer oil
- iii. C.R.G.O./ Amorphous Core
- iv. Insulating paper.
- v. Porcelain/Epoxy Bushings
- vi Steel Plate used for Tank

- 34.3 Names of the supplier for the raw material, list of standard accordingly to which the raw materials are tested, list of test normally carried out on raw materials in presence of bidder's representatives, copies of type test certificates to be furnished.

- 34.4 Information and copies of test certificate as in (33.3) above respect of bought out accessories including terminal connectors.

- 34.5 List of manufacturing facilities available, in this list the bidder shall specifically mention whether lapping machine, vacuum drying plant, air conditioned dust free room with positive air pressure for provision of insulation and winding etc are available with him.

- 34.6 Level of automation achieved and list of areas where manual processing still exists.

- 34.7 List of areas in manufacturing process where stage inspection are normally carried out for quality control and details of such tests and inspections.

- 34.8 Special features provided in the equipments to make it maintenance free

- 34.9 List of testing equipment available with the bidder for final testing of transformers and test plant limitation, if any, vis-à-vis the type, special acceptance and routine tests specified in the relevant standards and the present specification.

- 34.10 The successful bidder shall submit the Routine Test Certificate along with documentary evidence having paid for the excise duty for the following raw materials viz Oil, Copper for conductors, insulating materials, Core materials, Bushing at the time of routine Testing of the fully assembled transformer.

**34.0 Qualifying Requirement: As per Tender**

**36.0 Performance Guarantee:**

**TECHNICAL SPECIFICATIONS OF 630 kVA, THREE PHASE, 11/ 0.433 kV AND 22/0.433 kV COPPER WOUND, CRGO/AMORPHOUS CORE, ONAN DISTRIBUTION TRANSFORMER EEL- II ( STAR-II)**

---

All transformers supplied against this specification shall be guaranteed for a period of 66 months from the date of receipt at the consignee's Stores Center or 60 months from the date of commissioning, whichever is earlier. However, any engineering error, omission, wrong provisions, etc. which do not have any effect on the time period, shall be attended to as and when observed/ pointed out without any price implication.

**TECHNICAL SPECIFICATIONS OF 630 kVA, THREE PHASE, 11/ 0.433 kV AND 22/0.433 kV COPPER WOUND, CRGO/AMORPHOUS CORE, ONAN DISTRIBUTION TRANSFORMER EEL- II ( STAR-II)**

**Schedule `A'**

**GUARANTEED TECHNICAL PARTICULARS**

<b>630 KVA, 11 &amp; 22/0.433 KV ONAN Cu. Wound I/D Distribution Transformer Star 1 (Level-1)</b>		
<b>Sr. No</b>	<b>GTP Parameters</b>	<b>To be offered by Bidder</b>
1	Name of Manufacturer	Text
2	Reference Standards	Text
3	Rating of Transformer in KVA	Numerical
4	Primary voltage in kV	Numerical
5	Secondary voltage in kV	Numerical
6	Transformer shall be Oil Natural Air Natural (ONAN) type Yes/No	Text
7	Transformer shall be suitable for Indoor application. (Yes/No)	Text
9	Highest System Voltage in kV	Numerical
10	Frequency in HZ.	Numerical
11	Transformer shall be suitable for solid neutral earthing (Yes/No)	Boolean
12	Service condition shall be applicable as per Technical specification	Boolean
13	Transformer Colour as per IS:5	Text
14	Type of connection for H.V. Winding (Delta) (Yes/No).	Text
15	Type of connection for L.V. Winding (Star) (Yes/No)	Text
16	Vector Group Dyn-11 (Yes/No)	Text
17	Name Plate details are as per the requirement specified in tender (Yes/No)	Boolean
18	Thickness of Name plate (in SWG)	Numerical
19	Maximum temperature rise of Windings over an Ambient temp. of 50°C in °C	Numerical
20	Maximum temperature rise of oil over an Ambient temp. of 50°C in °C	Numerical
21	Approximate overall length of the Transformer in mm	Numerical
22	Approximate overall breadth of the Transformer in mm	Numerical

**TECHNICAL SPECIFICATIONS OF 630 kVA, THREE PHASE, 11/ 0.433 kV AND 22/0.433 kV COPPER WOUND, CRGO/AMORPHOUS CORE, ONAN DISTRIBUTION TRANSFORMER EEL- II ( STAR-II)**

23	Approximate overall height of the Transformer in mm	Numerical
24	Approximate length of the Transformer tank in mm	Numerical
25	Approximate breadth of the Transformer tank in mm	Numerical
26	Approximate height of the Transformer tank in mm	Numerical
27	Thickness of the side of transformer tank plates in mm	Numerical
28	Thickness of the bottom of transformer tank plates in mm	Numerical
29	Thickness of the top of transformer tank plates in mm	Numerical
30	Size of reinforced welded angle to the Transformer Tank in mm.	Text
31	Degree of slope to the top plate of Transformer.	Text
32	Shape of transformer Tank	Text
33	Type of Tank (Corrugated/ Conventional)	Text
34	In case of corrugated tank, thickness of corrugated sheet (in mm)	
35	Size of Transformer Base Channel in mm.	Text
36	Size (diameter & width) and No. of Rollers provided to the Transformer	Text
37	Conservator tank to the transformer with oil level indicator (showing three levels) and drain plug is provided ( Yes/ No)	Boolean
38	Dimensions of conservator Tank (LxD) in mm	Text
39	Drain Valve size (32 mm) provided to the transformer tank ( Yes/No)	Numerical
40	Size of Oil filling hole with cap in mm. (on conservator) is provided.	Numerical
42	Size of filter valve in mm. is provided.	Numerical
43	No. & Size in mm of Lifting lugs provided to transformer	Text
44	No. & Size in mm of pulling lugs provided to transformer	Text
45	No. & Size in mm of transformer top cover lifting lugs provided to transformer	Text
46	No. of Earthing terminals with suitable size in (SWG)	Numerical

**TECHNICAL SPECIFICATIONS OF 630 kVA, THREE PHASE, 11/ 0.433 kV AND 22/0.433 kV COPPER WOUND, CRGO/AMORPHOUS CORE, ONAN DISTRIBUTION TRANSFORMER EEL- II ( STAR-II)**

47	Thermometer pocket is provided (Yes/No)	Boolean
48	Quantity of Silica-Gel filled in breather ( in gm) & make of breather	Text
49	Explosion vent with diaphragm. (Yes/No)	Boolean
50	No of radiators both on HV & LV side provided and location with arrangement & size.	Text
51	Thickness of the radiator of transformer in mm. and fin size	Text
52	No of radiator fins.	Numerical
53	(A) Radiating surface of radiators in Sq. Mtrs.	Numerical
54	(B) Radiating surface of Tank only in Sq. Mtrs.	Numerical
55	Total radiating surface of transformer tank in Sq. mtrs.	Numerical
57	Weight of Core in kgs	Numerical
58	Weight of copper (Winding) in Kgs.	Numerical
59	Weight of Transformer Tank with fittings in Kgs.	Numerical
60	Weight of Oil in kgs	Numerical
61	Volume of Oil in Ltrs	Numerical
62	Total weight of Transformer in Kgs	Numerical
63	Rating of Lightning Arrestors and Make thereof (kV, kA)	
64	Reference Standard of Lightning Arrestors.	
65	Min. External Clearances of HV Bushing terminals between Ph to Ph (in mm )	Numerical
66	Min. External Clearances of HV Bushing terminals between Ph to E (in mm) (Indoor)	Numerical
67	Min. External Clearances of LV Bushing terminals between Ph to Ph (in mm)	Numerical
68	Min. External Clearances of LV Bushing terminals between Ph to E (in mm)	Numerical
69	The temperature shall in no case reach a value that will damage the core itself , other parts or adjacent materials (Yes/No)	Boolean
70	Type of Core (stacked/ wound)	Text
71	Core material used & its grade	Text

**TECHNICAL SPECIFICATIONS OF 630 kVA, THREE PHASE, 11/ 0.433 kV AND 22/0.433 kV COPPER WOUND, CRGO/AMORPHOUS CORE, ONAN DISTRIBUTION TRANSFORMER EEL- II ( STAR-II)**

72	Thickness of core lamination in mm	Numerical
73	No of steps used in CRGO Core	Numerical
74	Diameter of the core (in mm)	Numerical
75	Effective Core Area ( Sq. cm)	Numerical
76	Flux density at normal voltage and frequency in Tesla	Numerical
77	Material of H.V. Winding	Text
78	Material of L.V. Winding	Text
79	Size/diameter of conductor used for HV winding in mm	Numerical
80	Total cross section area of HV Winding in sq mm.	Numerical
81	Size of strip used for LV winding conductor in mm	Text
82	Total cross section of Copper used in LV Winding in sq. mm	Numerical
83	No. of conductors in parallel for LV winding	Numerical
84	Current density of HV winding , in Amps/sq. mm.	Numerical
85	Current density of LV winding, in Amps / sq.mm.	Numerical
86	No of HV winding Turns	Numerical
87	No of LV winding Turns	Numerical
88	No of H.V. coils /phase	Numerical
89	No. of L.V. coils/phase	Numerical
90	Resistance of HV winding at 20 ° C in Ohm/phase	Numerical
91	Resistance of LV winding at 20 ° C in Ohm/phase	Numerical
92	% impedance value at 75° C	Numerical
93	Name of manufacturers of oil	Text
94	Grade of Oil	Text
95	A. Minimum volume of oil in liters as per tech. specification	Numerical
96	B. Quantity of total oil absorption (in Ltrs) in first filling	Numerical
97	Total oil Volume including Total Oil absorption in liters i.e. (A+B)	Numerical

**TECHNICAL SPECIFICATIONS OF 630 kVA, THREE PHASE, 11/ 0.433 kV AND 22/0.433 kV COPPER WOUND, CRGO/AMORPHOUS CORE, ONAN DISTRIBUTION TRANSFORMER EEL- II ( STAR-II)**

98	Breakdown value of oil at the time of first filling (KV/mm) considering 2.5 mm gap	Numerical
99	Total volume of conservator shall be such as to content 10% of total quantity of oil (Yes/No)	Boolean
100	No load losses at rated voltage and frequency in Watts	Numerical
101	Max. Total losses (No load loss + Load Loss) at 50 % loading in Watts at 75°C	Numerical
102	Max. Total losses (No load loss + Load Loss) at 100 % loading in Watts at 75°C	Numerical
103	Magnetizing current (No load) in Amps & its % of full load current & rated voltage referred to LV side	Text
104	Magnetizing current (No load) in amps & its % of full load current at maximum voltage (112.5% of rated voltage ) referred to LV side	Text
105	Min Clearance between Core & L.V. in mm	Numerical
106	MinClearances between L.V. & H.V. in mm	Numerical
107	Min Clearances between winding to body of tank in mm	Numerical
108	Min Clearance between HV phase to phase in mm	Numerical
109	Min Clearances between end insulation to Earth in mm	Numerical
110	Insulation materials provided for core	Text
111	Insulation materials provided for H.V. Conductor	Text
112	Insulation materials provided for L.V. Conductor	Text
113	Thickness of locking spacers between HV coils in mm	Numerical
114	Inter layer insulation provided in H.V winding to design for Top & bottom layer	Text
115	Inter layer insulation provided in L.V winding to design for Top & bottom layer	Text
116	Inter layer insulation provided in between all layer in H.V winding	Text
117	Inter layer insulation provided in between all layer in L.V winding	Text
118	Details of end insulation (thickness in mm)	Numerical
119	Whether wedges are Provided at 50% turns of the Coil (Yes/ No)	Boolean

**TECHNICAL SPECIFICATION OF 630KVA, 11/0.433 KV, 22/0.433 KV Energy Efficiency  
 Level -1 THREE PHASE, INDOOR TYPE OIL IMMersed DISTRIBUTION TRANSFORMERS**

120	Thickness of insulating paper	Numerical
121	Regulation at 0.8 P.F. lag ( in % )	Numerical
122	Regulation at 0.8 P.F. leading ( in % )	Numerical
123	Regulation at unity P.F.. (in %)	Numerical
124	Reference standard of Bushing	Text
125	Material of HV and L.V Bushings	Text
126	Makes of HV and L.V Bushings	Text
127	Rating of HV Bushing ( in KV,A)	Text
128	Rating of LV Bushing (in KV,A)	Text
129	Minimum Creepage Distance of HV Bushings in mm (min 25mm/kV)	Numerical
130	Minimum Creepage Distance of LV Bushings in mm (min 25mm/kV)	Numerical
131	Power frequency withstand voltage dry & wet in kV(rms) for HV Bushings	Numerical
132	Dry lightning impulse withstand voltage test in kV (Peak) stating the waveform adopted for HV Bushing.	Numerical
133	Separate source power frequency withstand test for HV for 1minute in kV(min)	Numerical
134	Separate source power frequency withstand test for LV for 1minute in kV(min)	Numerical
135	Induced over voltage withstand test for 1 min. specify voltage frequency, time for test.	Text
136	Impulse test value (in kVp) .	Numerical
139	Efficiency at 75 ° C at unity P.F. at 125 % Load	Numerical
140	Efficiency at 75 ° C at unity P.F at 100 % Load	Numerical
141	Efficiency at 75 ° C at unity P.F. at 75 % Load	Numerical
142	Efficiency at 75 ° C at unity P.F. at 50 % Load	Numerical
143	Efficiency at 75 ° C at 0.8 P.F. lag at 125 % Load	Numerical
144	Efficiency at 75 ° C at 0.8 P.F. lag at 100 % Load	Numerical
145	Efficiency at 75 ° C at 0.8 P.F. lag at 75 % Load	Numerical

**TECHNICAL SPECIFICATIONS OF 630 kVA, THREE PHASE, 11/ 0.433 kV AND 22/0.433 kV COPPER WOUND, CRGO/AMORPHOUS CORE, ONAN DISTRIBUTION TRANSFORMER EEL- II ( STAR-II)**

146	Efficiency at 75 ° C at 0.8 P.F. lag at 50 % Load	Numerical
147	Efficiency at 75 ° C at 0.8 P.F. lag at 25 % Load	Numerical
148	Efficiency at 75 ° C at 0.8 P.F. leading at 125 % Load	Numerical
149	Efficiency at 75 ° C at 0.8 P.F. leading at 100 % Load	Numerical
150	Efficiency at 75 ° C at 0.8 P.F. leading at 75 % Load	Numerical
151	Efficiency at 75 ° C at 0.8 P.F. leading at 50 % Load	Numerical
152	Efficiency at 75 ° C at 0.8 P.F. leading at 25 % Load	Numerical
153	The test certificates of copper conductors, core , insulating paper, porcelain Bushings, steel plate used for enclosure of the offered transformer are enclosed with the offer (Yes/No)	Boolean
154	All type test report carried out on transformer at NABL laboratory shall be submitted along with the offer as per cl. XXII (c) of Section (I) i.e. Instructions to tenderers. (Yes/No). Firm may attach online.	Boolean
155	Unbalance current test, Air pressure test and temperature rise test shall be conducted as per format enclosed with the technical specification along with the offer (Yes/ No)	Boolean
156	All drawings shall be furnished for each offered item separately along with this offer(Yes/ No)	Boolean
157	Oil absorption calculation sheet shall be furnished for each offered item separately along with this offer (Yes/ No)	Boolean
158	Heat dissipation calculation shall be furnished for each offered item separately along with this offer (Yes/ No)	Boolean
159	Calculation sheet submitted for Flux density calculations (stating HV & LV turns) for each offered item separately along with the offer (Yes/No)	Boolean
160	Calculation sheet for 112% of rated V/f ratio (Over fluxing) calculation sheet shall be furnished for each item separately along with this offer (Yes/No)	Boolean

**TECHNICAL SPECIFICATIONS OF 630 kVA, THREE PHASE, 11/ 0.433 kV AND 22/0.433 kV COPPER WOUND, CRGO/AMORPHOUS CORE, ONAN DISTRIBUTION TRANSFORMER EEL- II ( STAR-II)**

161	Required documents, plant and machinery, testing equipment , list of order executed/under execution shall be furnished for each offered item separately along with this offer (Yes/ No)	Boolean
162	The information required under Quality Assurance shall be submitted with the offer in physical format & soft copy(Yes/ No)	Boolean
163	The cost data in the prescribed format shall be submitted with offer in physical format & soft copy (Yes/ No)	Boolean
164	The performance Guarantee of the transformers in years	Text
165	Dimensions in mm of Air filled HV Cable Box provided suitable for 3 Core XLPE cables up to 300 sq.mm with gland plates as per tech spec. cl.no.13.8	Text
166	Dimensions in mm of Air filled LV Cable Box provided suitable for single core 400 sq.mm cable i.e. 3 cable run/ phase and 1cablerun for neutral with gland plates as per tech spec. cl.no.13.8	Text
167	HV and LV cable Boxes provided shall be rectangular , M.S.Sheet of 2 mm , weather , vermin, and dustproof	Text
168	LV Cable Box shall be provided non magnetic gland plates	Boolean

**Annexure IV- Technical specification for QR Code generation**

**TECHNICAL SPECIFICATIONS OF 630 kVA, THREE PHASE, 11/ 0.433 kV AND 22/0.433 kV COPPER WOUND, CRGO/AMORPHOUS CORE, ONAN DISTRIBUTION TRANSFORMER EEL- II ( STAR-II)**

---

1. SCOPE: The QR Code Generation for Distribution Transformer Identification should be easy to create, compact in size and friendly user. Being compact in size the QR Code requires less space.

2. SERVICE CONDITIONS:

The QR Code laminated P-Touch labels shall be suitable for satisfactory operation under the following tropical conditions.

2.1	Maximum ambient temperature (Degree C)	50
2.2	Maximum temperature in shade (Degree C)	45
2.3	Minimum Temperature (Degree C)	3.5
2.4	Relative Humidity (percent)	10 to 95
2.5	Maximum Annual rain fall (mm)	1450
2.6	Maximum wind pressure (kg/sq.m)	150
2.7	Maximum altitude above mean sea level ( Meter)	1000
2.8	Isoceranic level (days per year)	50
2.9	Seismic level (Horizontal Acceleration)	0.3 g

Moderately hot and humid tropical climate conducive to rust and fungus growth ....

3. GENERAL TECHNICAL REQUIREMENT:

The QR Code shall be laminated P-Touch labels. The QR Code shall be 2D square barcode which can be store data in encoded format. This saves space and giving specified information to users. This QR Code,if scanned with mobile shall be convert encoded data readable text without error.

4. TECHNICAL DETAILS :

The QR Code laminated P-Touch labels shall be temperature resistant, fade resistant, water resistant, chemical resistant, scratch ( abrasion ) proof and strong adhesion.

5. TECHNICAL DATA :

The QR Code laminated P-Touch labels with following data shall be provided on transformer.

- 1) Name of Manufacture :
- 2) Rating :
- 3) Sr. No. :
- 4) Date of Manufacturing :
- 5) A/T No. :

6. LOCATION OF QR CODE :

The QR Code laminated P-Touch labels shall be located below the Name Plate on transformer body. It should be clearly visible.

The example of QR Code laminated P-Touch labels location as below :

**TECHNICAL SPECIFICATIONS OF 630 kVA, THREE PHASE, 11/ 0.433 kV AND 22/0.433 kV COPPER WOUND, CRGO/AMORPHOUS CORE, ONAN DISTRIBUTION TRANSFORMER EEL- II ( STAR-II)**

MFD. BY:-

<b>3 PHASE AL WOUND TRANSFORMER</b>			
TYPE	OUTDOOR		
STANDARD	IS:1180 PART-1	ENERGY EFFICIENCY LEVEL	2
kVA	100	MAX. TOTAL LOSSES AT 50% RATED LOAD	475
VOLTS-AT NO LOAD	HV	11000	MAX. TOTAL LOSSES AT 100% RATED LOAD
	LV	433	1650
BIL	HV	75	TEMP RISE
	LV	—	TEMP RISE
AMPERS	HV	5.25	TEMP RISE
	LV	133.34	TEMP RISE
FREQUENCY Hz	50	TEMP RISE	TEMP RISE
VECTOR GROUP	Dyn-11	TEMP RISE	TEMP RISE
IMPEDANCE VOLT %		TEMP RISE	TEMP RISE
CUSTOMER	MAHARASHTRA STATE ELECTRICITY DISTRIBUTION CO. LTD.		
ORDER NUMBER	LOA NO.		

MADE IN INDIA

CONNECTIONS & VECTOR DIAGRAM :

The diagram shows a three-phase star-delta connection. The primary (HV) is a star connection with terminals 2N, 2U, 2V, 2W. The secondary (LV) is a delta connection with terminals 1U, 1V, 1W. The vector diagram shows the primary voltage vectors 1U, 1V, 1W and the secondary voltage vectors 2u, 2v, 2w, with a phase shift of 30 degrees between them, characteristic of a Dyn11 connection.



QRcode for details.

**TECHNICAL SPECIFICATIONS OF 630 kVA, THREE PHASE, 11/ 0.433 kV AND 22/0.433 kV COPPER WOUND, CRGO/AMORPHOUS CORE, ONAN DISTRIBUTION TRANSFORMER EEL- II ( STAR-II)**

---



**TECHNICAL SPECIFICATIONS OF 630 kVA, THREE PHASE, 11/ 0.433 kV AND 22/0.433 kV COPPER WOUND, CRGO/AMORPHOUS CORE, ONAN DISTRIBUTION TRANSFORMER EEL- II ( STAR-II)**

**Annexure I**

Air Pressure Test

Name of Supplier:

Order No.:

Capacity & Voltage Ratio of Distribution Transformer : \_\_\_\_\_kVA, \_\_\_\_\_/0.433 kV

Vector Group Dyn11

Sr. No. of equipment Tested:

Date of Testing:

Reference Standard

All the opening of the transformer tank were closed with suitable gasket, bushing, valves and plugs. The compressor pipe connected at oil filling hole on conservator and a pressure guage was fitted at air vent plug. The parallel string were places around the tank, the distance between string and tank as shown in following diagram were recorded before applying the pressure and after releasing pressure.

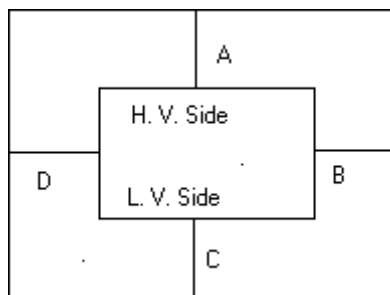

Tank Thickness: Side \_\_\_\_\_mm. Top & Bottom \_\_\_\_\_mm

Test Pressure : \_\_\_\_\_kg/cm<sup>2</sup> applied for 30 Minutes.

Test Point	Distance before Test In mm	Distance after release of Pressure in mm	Deflection In mm
A			
B			
C			
D			

Permanent Deflection : \_\_\_\_\_mm

Permissible Limit of Permanent Deflection as per Specification : \_\_\_\_\_mm

Test witnessed by

Tested by

**TECHNICAL SPECIFICATIONS OF 630 kVA, THREE PHASE, 11/ 0.433 kV AND 22/0.433 kV COPPER WOUND, CRGO/AMORPHOUS CORE, ONAN DISTRIBUTION TRANSFORMER EEL- II ( STAR-II)**

---

**Annexure II**

**Unbalance Current Test**

Name of Supplier:

Order No.:

Capacity & Voltage Ratio of Distribution Transformer : \_\_\_\_\_kVA, \_\_\_\_\_/0.433 kV

Vector Group Dyn11

Sr. No. of equipment Tested:

Date of Testing:

Reference Standard

---

Transformer Secondary terminals 2U, 2V & 2W are shorted. The shorted 2U, 2V & 2W is connected to 2N through Ammeter. The primary terminals 1U, 1V & 1W are connected to supply. The rated current\_A is fed to primary and unbalance current is noted on Ammeter.

Unbalance Current Measured in Ammeter : \_\_\_\_\_ A

Rated current in Secondary Side : \_\_\_\_\_A

Permissible limits as per specification : 2% of the Rated current in Secondary Side

% of Unbalance current with reference to Rated current in Secondary Side

$$= \frac{\text{Unbalance Current} \times 100}{\text{Rated current in Secondary Side}}$$

=

=

Test witnessed by

Tested by



**TECHNICAL SPECIFICATIONS OF 630 kVA, THREE PHASE, 11/ 0.433 kV AND 22/0.433 kV COPPER WOUND, CRGO/AMORPHOUS CORE, ONAN DISTRIBUTION TRANSFORMER EEL- II ( STAR-II)**

Calculation of Temperature Rise in Winding

LV Winding : Since the resistance of LV winding is less than 0.005 ohm, Temperature Rise in LV Winding is taken as temperature rise of oil as per clause no. 4.3 of IS:2026 (Part II)/1977

Temperature Rise in LV Winding = \_\_\_\_\_ °C

HV Winding Resistance across 1U1V at \_\_\_\_\_ °C = \_\_\_\_\_ ohm

Measurement of Hot Resistance of HV Winding after Shut Down.

Time	Resistance

Hot winding Resistance at Ambient Temperature \_\_\_\_\_ °C (from graph) = \_\_\_\_\_ Ohm

Temperature Rise in H. V. Winding is

$$= \frac{\text{Hot Resistance} \times (235 + \text{Cold Ambient Temperature})}{\text{Cold Resistance}} - (235 + \text{Hot Ambient Temperature})$$

=

=

Results :

- 1) Temperature Rise in Oil = \_\_\_\_\_ °C
- 2) Temperature Rise in LV Winding = \_\_\_\_\_ °C
- 3) Temperature Rise in HV Winding = \_\_\_\_\_ °C
- 4) Oil leakage test:

The oil leakage test shall be conducted on one unit selected from the offered lot of each rating. Transformer complete in all respects shall be subjected to the pressure of 0.4 kg/cm<sup>2</sup> and maintained for 8 hours . No leakage should occur.

Test witnessed by

Tested by

**TECHNICAL SPECIFICATIONS OF 630 kVA, THREE PHASE, 11/ 0.433 kV AND 22/0.433 kV COPPER WOUND, CRGO/AMORPHOUS CORE, ONAN DISTRIBUTION TRANSFORMER EEL- II ( STAR-II)**

TECHNICAL SPECIFICATIONS OF 630 kVA, THREE PHASE, 11/ 0.433 kV AND 22/0.433 kV COPPER WOUND, CRGO/AMORPHOUS CORE, ONAN DISTRIBUTION TRANSFORMER EEL- II ( STAR-II)

115

145

4 HOLES Ø3

REF. STANDARD : IS 2026-1977 & IS 1200  
3 STAR RATING, 3 PH. DISTRIBUTION TRANSFORMER

TYPE	OUT DCCR	TYPE OF COOLING	ONAN
RATED KVA	---	OIL TEMP. RISE	T <sub>1</sub> 35
RATED HV (V)	11000	WDG TEMP RISE	Z <sub>1</sub> 40
VOLTAGE LV (V)	433	VOLUME OF OIL	l
RATED HV (A)	---	MASS OF OIL	kg
CURRENT LV (A)	---	WEIGHT OF CORE	kg
PHASES	3	WEIGHT OF WDGs	kg
FREQUENCY Hz	50	TOTAL MASS	kg
IMPEDANCE %	---	SERIAL NO	
GUARANTEED TOTAL LOSS (W)	---	LOSS IN WATTS	
INSULATION LEVEL	U75 AC 2B	CORE	CRGO/AMDT
VECTOR GROUP	Dyn-11	MONTH & YEAR OF MFG	---
OWNER	MSEDCL, MUMBAI.		
A/T.NO.			

CONNECTION DIAGRAM

VECTOR DIAGRAM

**NOTE:**

1. ACTUAL VALUES SHALL BE PUNCHED AT THE TIME OF DISPATCH.
2. RATING PLATE MATERIAL: ALUMINIUM ANODIZED
3. THICKNESS OF RATING PLATE: 18 SWG
4. WEIGHTS ARE SUBJECTED TO +10% TOLERANCE

THIS IS AN INDICATIVE DRAWING

NAME OF THE CUSTOMER: MSEDCL, MUMBAI-51  
A/T. NO.  
QUANTITY  
DETAILS OF DISTRIBUTION TRANSFORMER: ---KVA, 11/0.433KV

NAME OF THE MANUFACTURE & SYMBOL

DATE	<b>RATING &amp; TERMINAL MARKING PLATE</b> ---KVA, 11/0.433KV CRGO/AMDT, DIST. TRANSFORMER	
DRN		
CHD	SCALE	DRG. NO
APPD		
--- KVA		NTS

MAHARASHTRA STATE

DISTRIBUTION CO.

MUMBAI

Tech Spec No. CE/T-QC/MSD/630kVA DTC dtd. 06.02.2025.

Page 106 of 133









### TRANSFORMER BUSHING AS PER IS:3347

**ELECTRICAL CHARACTERISTICS:**

1. RATED VOLTAGE : 1 KV
2. RATED CURRENT : 250 Amp
3. POWER FREQUENCY WITHSTAND VOLTAGE : 3 KV
4. CREEPAGE DISTANCE : 25 MM. (MIN.)

**NOTE:**

PERFORMANCE REQUIREMENTS OF THE BUSHING SHALL CONFIRM TO IS: 3347

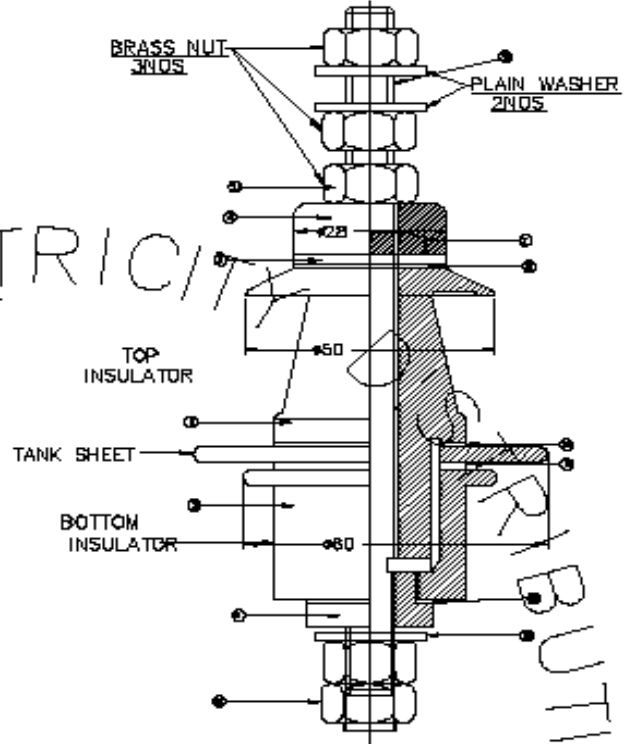

MAKE: / /

SIL. No.	DESCRIPTION	QTY
1	INSULATOR UPPER	1
2	INSULATOR LOWER	1
3	PLAIN WASHER	1
4	TOP END WASHER	1
5	ITEM WASHER	1
6	IRON WASH	1
7	SEALING WASHER (TYPE-A)	1
8	SEALING WASHER (TYPE-B)	1
9	SEALING WASHER (TYPE-C)	1
10	SEALING WASHER (TYPE-D)	1
11	SEALING WASHER (TYPE-E)	1
12	SEALING WASHER (TYPE-F)	1
13	HEXLOCK NUT-M12	1
14	PLAIN WASHER-M12	1
15	SEALING WASHER (TYPE G)	1

NAME OF THE CUSTOMER: MSEDCL, MUMBAI-51  
A.T. NO. MUMBAI  
QUANTITY: MUMBAI  
DETAILS OF DISTRIBUTION TRANSFORMER: 100KVA, 11/0.433KV, CSP

NAME OF THE MANUFACTURE & SYMBOL	
A/T. NO.	
Notes	
LV BUSHING ASSEMBLY DRAWING 100KVA, 11/0.433KV CSP DIST. TRANSFORMER	
CHD	DRG. NO
APPD	

THIS IS AN INDICATIVE DRAWING

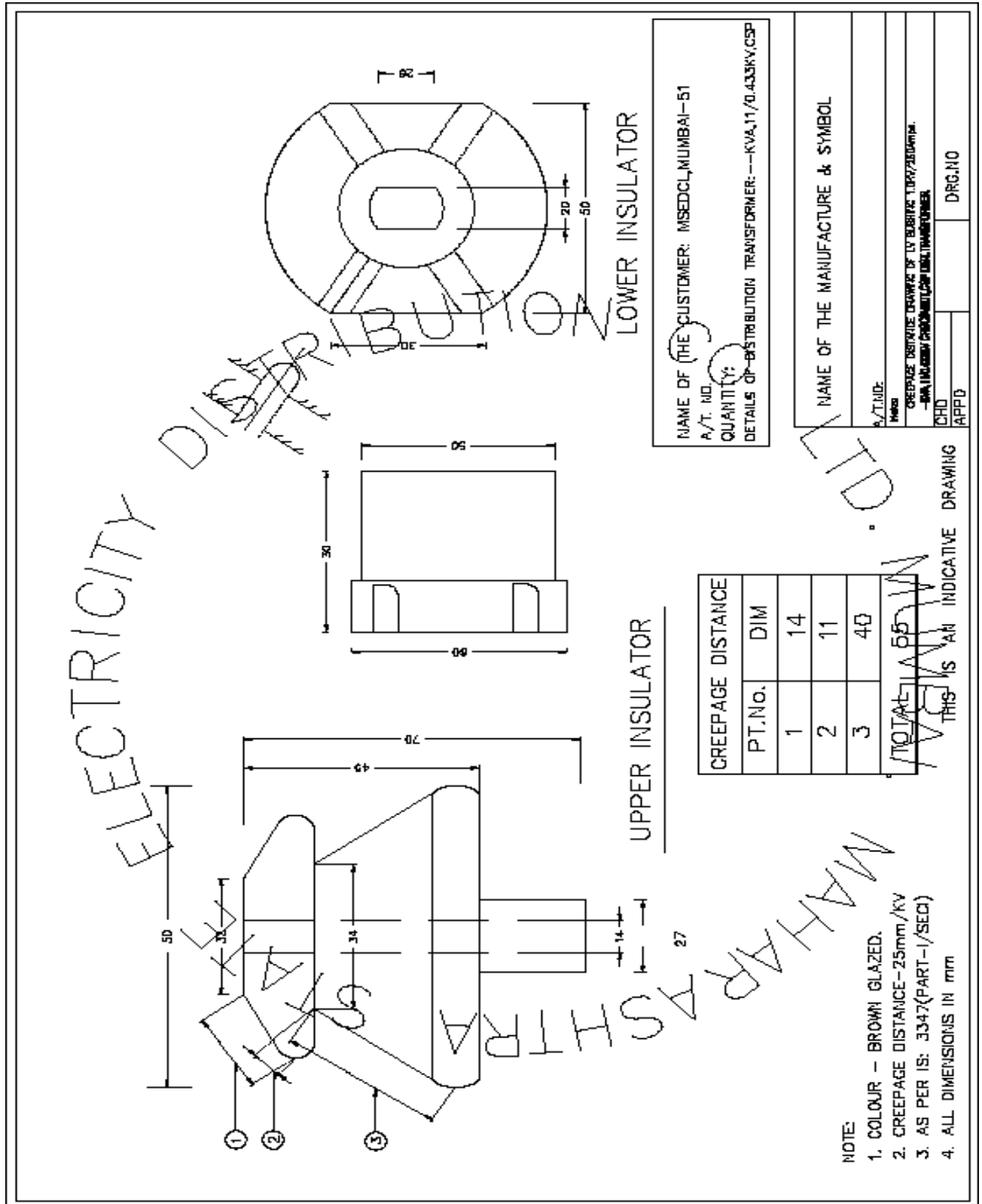

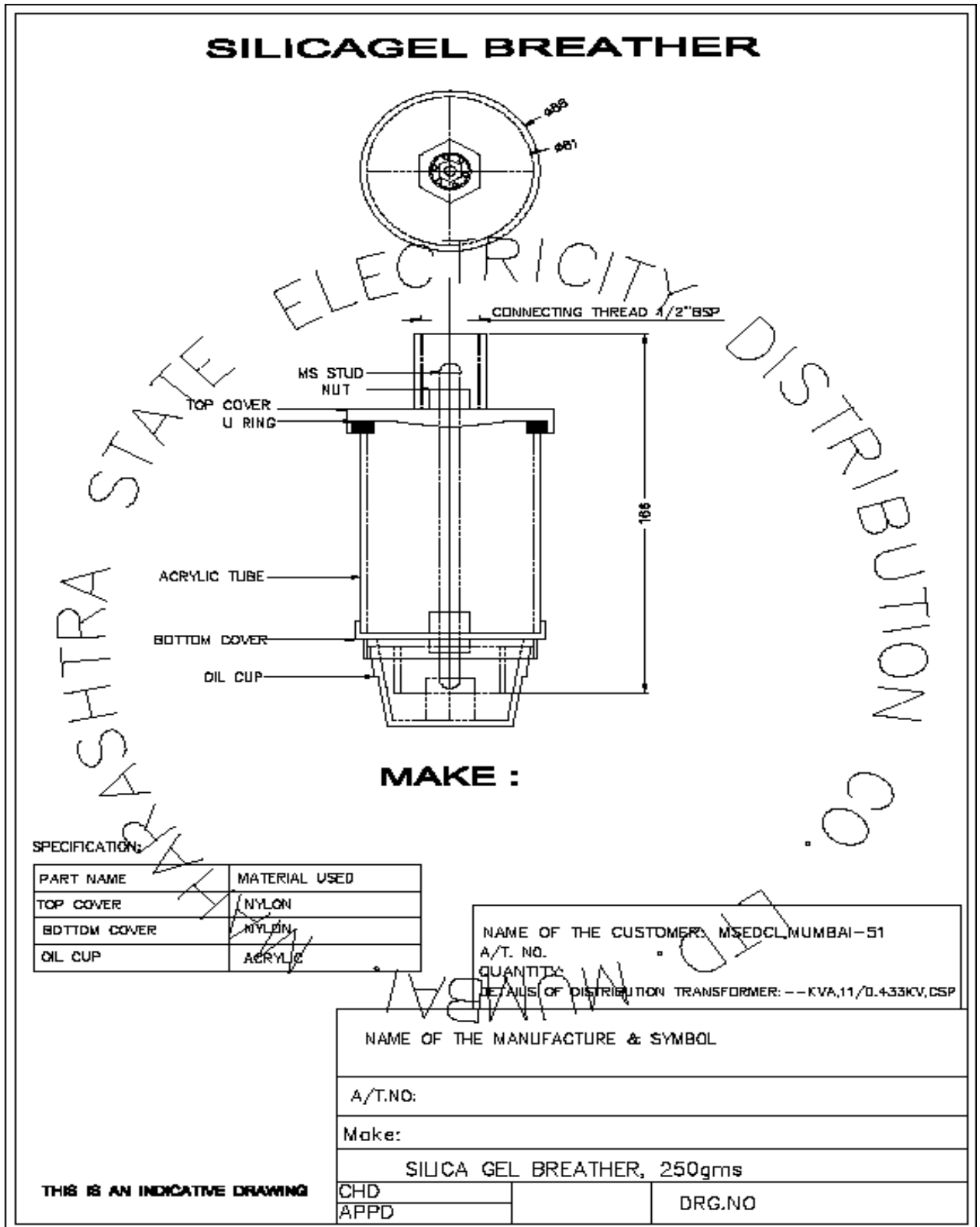





TECHNICAL SPECIFICATIONS OF 630 kVA, THREE PHASE, 11/ 0.433 kV AND 22/0.433 kV COPPER WOUND, CRGO/AMORPHOUS CORE, ONAN DISTRIBUTION TRANSFORMER EEL- II ( STAR-II)

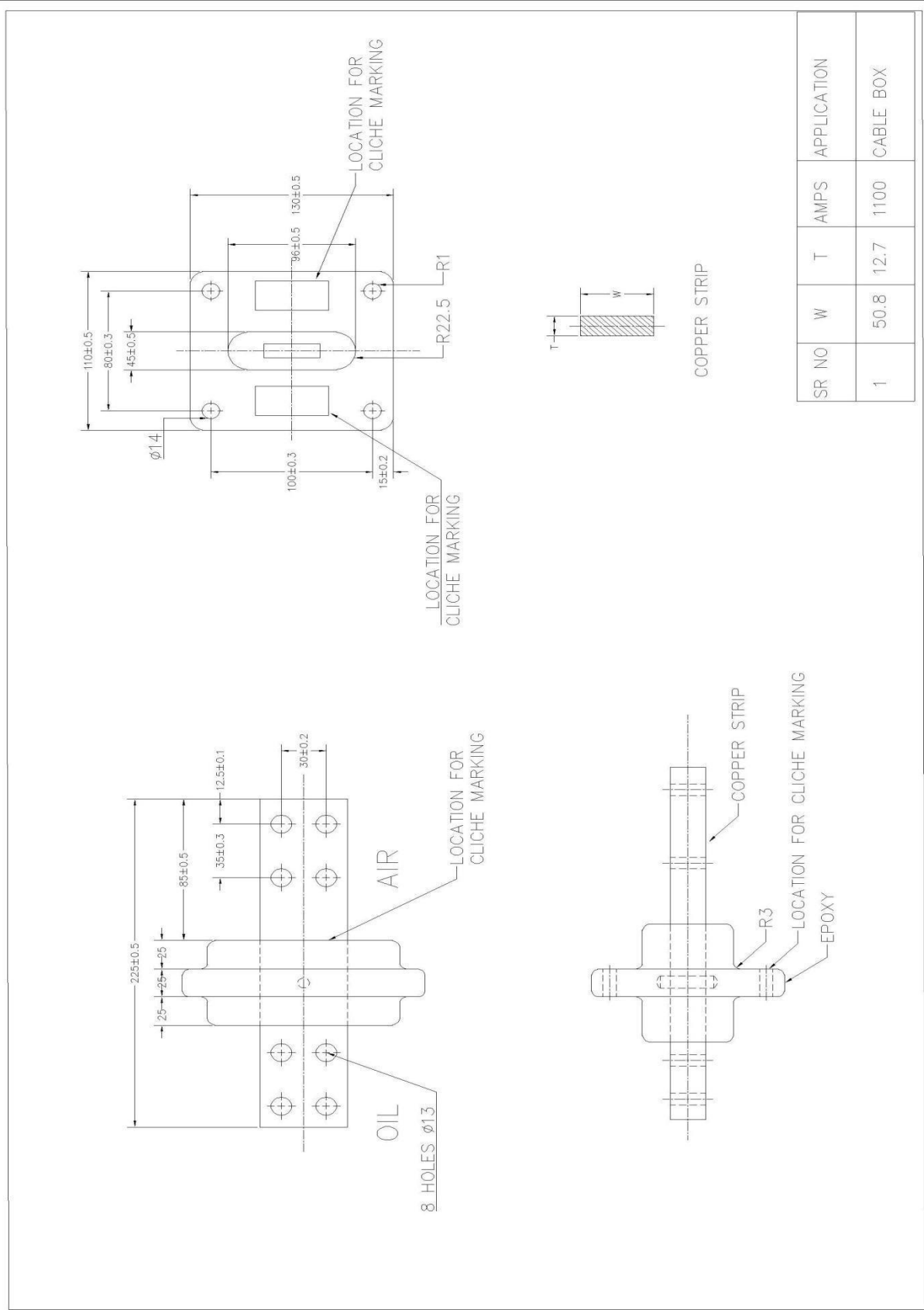

**TECHNICAL SPECIFICATIONS OF 630 kVA, THREE PHASE, 11/ 0.433 kV AND 22/0.433 kV COPPER WOUND, CRGO/AMORPHOUS CORE, ONAN DISTRIBUTION TRANSFORMER EEL- II ( STAR-II)**

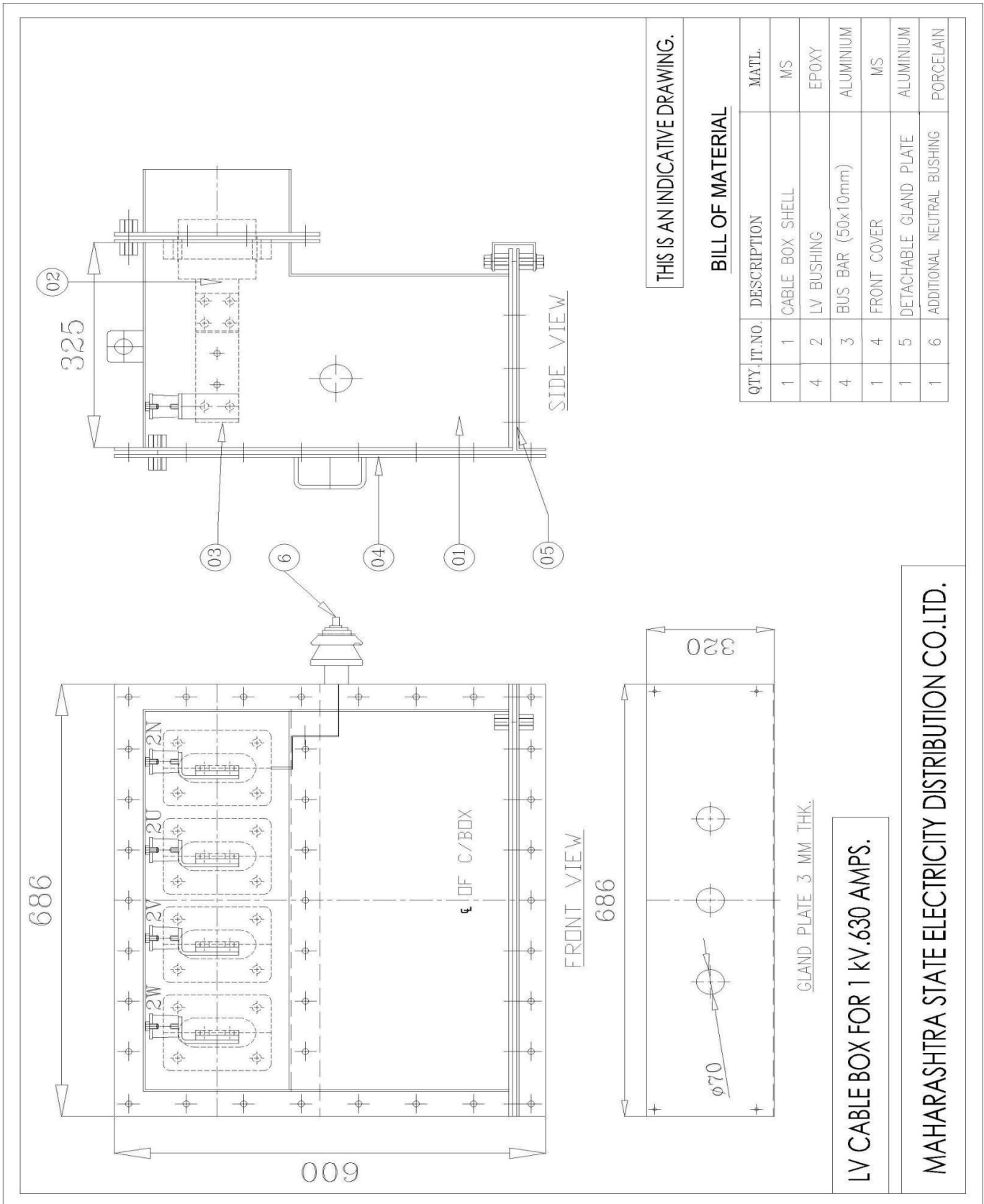

THIS IS AN INDICATIVE DRAWING.

**BILL OF MATERIAL**

QTY.	IT.NO.	DESCRIPTION	MATL.
1	1	CABLE BOX SHELL	MS
4	2	LV BUSHING	EPOXY
4	3	BUS BAR (50x10mm)	ALUMINIUM
1	4	FRONT COVER	MS
1	5	DETACHABLE GLAND PLATE	ALUMINIUM
1	6	ADDITIONAL NEUTRAL BUSHING	PORCELAIN

MAHARASHTRA STATE ELECTRICITY DISTRIBUTION CO.LTD.

**TECHNICAL SPECIFICATIONS OF 630 kVA, THREE PHASE, 11/ 0.433 kV AND 22/0.433 kV COPPER WOUND, CRGO/AMORPHOUS CORE, ONAN DISTRIBUTION TRANSFORMER EEL- II ( STAR-II)**

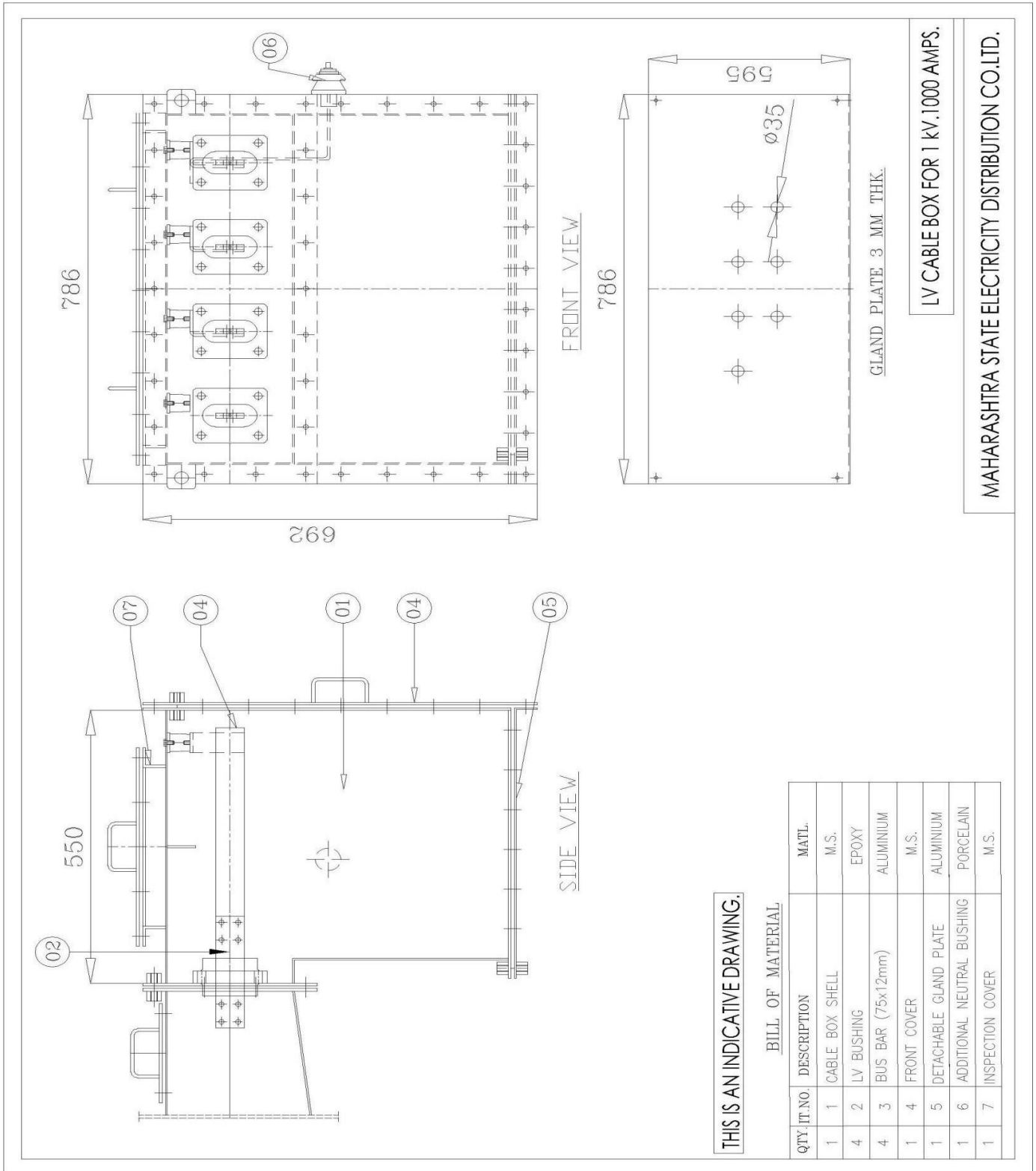

**THIS IS AN INDICATIVE DRAWING.**

**BILL OF MATERIAL**

QTY./IT.NO.	DESCRIPTION	MATL.
1	CABLE BOX SHELL	M.S.
4	LV BUSHING	EPOXY
4	BUS BAR (75x12mm)	ALUMINIUM
1	FRONT COVER	M.S.
1	DETACHABLE GLAND PLATE	ALUMINIUM
1	ADDITIONAL NEUTRAL BUSHING	PORCELAIN
1	INSPECTION COVER	M.S.

**TECHNICAL SPECIFICATIONS OF 630 kVA, THREE PHASE, 11/ 0.433 kV AND 22/0.433 kV COPPER WOUND, CRGO/AMORPHOUS CORE, ONAN DISTRIBUTION TRANSFORMER EEL- II ( STAR-II)**

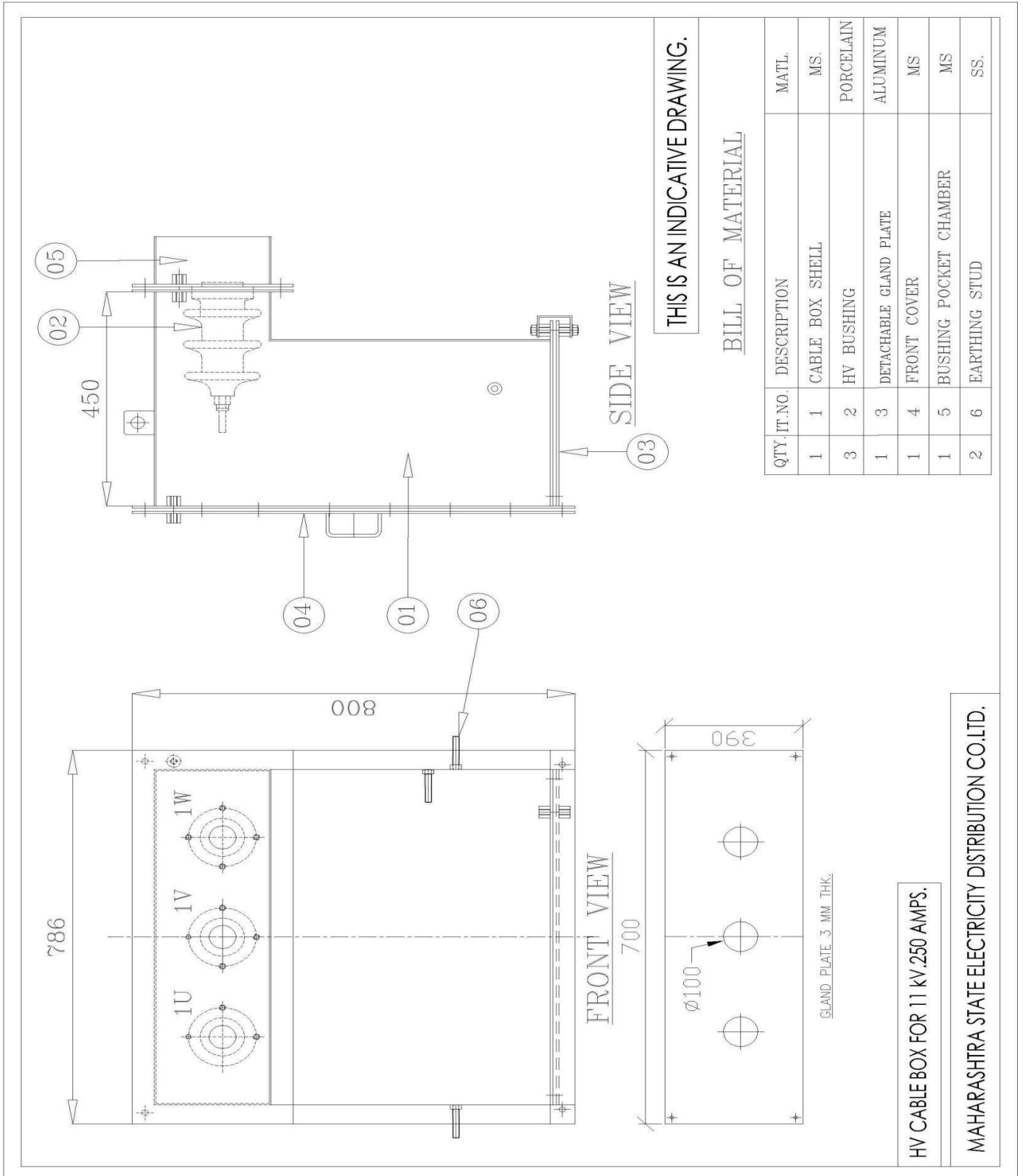

**THIS IS AN INDICATIVE DRAWING.**

BILL OF MATERIAL

QTY.	IT.NO.	DESCRIPTION	MATL.
1	1	CABLE BOX SHELL	MS.
3	2	HV BUSHING	PORCELAIN
1	3	DETACHABLE GLAND PLATE	ALUMINUM
1	4	FRONT COVER	MS
1	5	BUSHING POCKET CHAMBER	MS
2	6	EARTHING STUD	SS.

**HV CABLE BOX FOR 11 KV,250 AMPS.**

**MAHARASHTRA STATE ELECTRICITY DISTRIBUTION CO.LTD.**



**TECHNICAL SPECIFICATIONS OF 630 kVA, THREE PHASE, 11/ 0.433 kV AND 22/0.433 kV COPPER WOUND, CRGO/AMORPHOUS CORE, ONAN DISTRIBUTION TRANSFORMER EEL- II ( STAR-II)**

**MORE STARS  
MORE SAVINGS**

**POWER SAVINGS  
GUIDE**

<b>Total Losses at * :</b>	
<b>50% loading</b>	<b>- 1745Watts</b>
<b>100% loading</b>	<b>- 4850 Watts</b>

<b>Equipment</b>	: Distribution Transformer
<b>Type</b>	: Oil Filled naturally cooled
<b>Make</b>	:
<b>Model / year</b>	: 630/2S/2025
<b>Capacity</b>	: 630 KVA
<b>Voltage</b>	: upto 11kv

ENERGY IS LIFE  
CONSERVE IT

\*Under test conditions, when tested in accordance with IS 1180: (Part-1)-2014

NOTE:

- 1) THE UNIQUE LABEL SERIES CODE PROVIDED IN THE LETTER HAS TO BE MENTIONED IN THE LABEL AFFIXED ON THE DISTRIBUTION TRANSFORMER.
- 2) THE LABEL DESIGN, SIZE, COLOR SCHEME, MATERIAL TO BE USED, THE LABEL CONTENT OF LABEL, AND COLOR SCHEME OF BUREAU'S LOGO SHALL BE AS SCHEDULED OF THE BUREAU OF ENERGY EFFICIENCY PARTICULARS AND MANNER OF THEIR DISPLAY ON LABELS OF DISTRIBUTION TRANSFORMER REGULATION 2009

NAME OF CUSTOMER	MSEDCL MUMBAI-51
PROJECT	ALL ON GOING MSEDCL SCHEMES
DETAILS OF DIST.TRF	630 KVA 11/0.433 KV DISTRIBUTION TRANSFORMER

SIGNATURE OF AUTHORISED PERSON & STAMP OF THE FIRM	
----------------------------------------------------	--

<b>STAR LABEL OF "BEE" (STAR-2) DRAWING</b>	
DRG. NO.	630 KVA, 11/0.433 KV ALU WOUND, CRGO CORE DISTRIBUTION TRANSFORMER
REV.	- ENERGY EFFICIENCY LEVEL-2
TOL.	NO NEG.
SCALE	NTS
CUST.	MAHARASHTRA STATE ELECTRICITY DISTRIBUTION CO. LTD., MUMBAI

## Technical Specification Cont

Item	Technical Specification
630KVA,22/0.4KV3phDT/ID/CRGO/Star2/EEL-2/5yGP(20119986773)	Refer To The Following Item Specification: 630KVA,11/0.4KV3phDT/ID/CRGO/Star2/EEL-

630KVA,11/0.4KV3phDT/ID/CRGO/Star2/EEL-2/5yGP

GTP Order Sequence	GTP Parameters	Date Type
1	Name of Manufacturer	TEXT
2	Reference Standards	TEXT
3	Rating of Transformer in KVA	NUMERIC
4	Primary voltage in kV	NUMERIC
5	Secondary voltage in kV	TEXT
6	Transformer shall be Oil Natural Air Natural (ONAN) type Yes/No	BOOLEAN
7	Transformer shall be suitable for Indoor application. (Yes/No)	BOOLEAN
8	Highest System Voltage in kV	NUMERIC
9	Frequency in HZ.	TEXT
10	Transformer shall be suitable for solid neutral earthing (Yes/No)	BOOLEAN
11	Service condition shall be applicable as per Technical specification	BOOLEAN
12	Transformer Colour as per IS:5	TEXT
13	Type of connection for H.V. Winding (Delta) (Yes/No).	TEXT
14	Type of connection for L.V. Winding (Star) (Yes/No)	TEXT
15	Vector Group Dyn-11 (Yes/No)	TEXT
16	Name Plate details are as per the requirement specified in tender (Yes/No)	BOOLEAN
17	Thickness of Name plate (in SWG)	NUMERIC
18	Maximum temperature rise of Windings over an Ambient temp. of 50°C in °C	NUMERIC
19	Maximum temperature rise of oil over an Ambient temp. of 50°C in °C	NUMERIC
20	Approximate overall length of the Transformer in mm	NUMERIC
21	Approximate overall breadth of the Transformer in mm	NUMERIC
22	Approximate overall height of the Transformer in mm	NUMERIC
23	Approximate length of the Transformer tank in mm	NUMERIC
24	Approximate breadth of the Transformer tank in mm	NUMERIC
25	Approximate height of the Transformer tank in mm	TEXT
26	Thickness of the side of transformer tank plates in mm	NUMERIC
27	Thickness of the bottom of transformer tank plates in mm	NUMERIC
28	Thickness of the top of transformer tank plates in mm	NUMERIC
29	Size of reinforced welded angle to the Transformer Tank in mm.	TEXT
30	Degree of slope to the top plate of Transformer.	TEXT
31	Shape of transformer Tank	TEXT

32	Type of Tank (Corrugated/ Conventional)	TEXT
33	In case of corrugated tank, thickness of corrugated sheet (in mm)	TEXT
34	Size of Transformer Base Channel in mm.	TEXT
35	Size (diameter & width) and No. of Rollers provided to the Transformer	TEXT
36	Conservator tank to the transformer with oil level indicator (showing three levels) and drain plug is provided ( Yes/ No)	BOOLEAN
37	Dimensions of conservator Tank (LxD) in mm	TEXT
38	Drain Valve size (32 mm) provided to the transformer tank ( Yes/No)	NUMERIC
39	Size of Oil filling hole with cap in mm. (on conservator) is provided.	NUMERIC
40	Size of filter valve in mm. is provided.	NUMERIC
41	No. & Size in mm of Lifting lugs provided to transformer	TEXT
42	No. & Size in mm of pulling lugs provided to transformer	TEXT
43	No. & Size in mm of transformer top cover lifting lugs provided to transformer	TEXT
44	No. of Earthing terminals with suitable size in (SWG)	TEXT
45	Thermometer pocket is provided (Yes/No)	BOOLEAN
46	Quantity of Silica-Gel filled in breather ( in gm) & make of breather	TEXT
47	Explosion vent with diaphragm. (Yes/No)	BOOLEAN
48	No of radiators both on HV & LV side provided and location with arrangement & size.	TEXT
49	Thickness of the radiator of transformer in mm. and fin size	TEXT
50	No of radiator fins.	NUMERIC
51	(A) Radiating surface of radiators in Sq. Mtrs	NUMERIC
52	(B) Radiating surface of Tank only in Sq. Mtrs.	NUMERIC
53	Total radiating surface of transformer tank in Sq. mtrs.	NUMERIC
54	Weight of Core in kgs	NUMERIC
55	Weight of copper (Winding) in Kgs.	NUMERIC
56	Weight of Transformer Tank with fittings in Kgs.	NUMERIC
57	Weight of Oil in kgs	NUMERIC
58	Volume of Oil in Ltrs	NUMERIC
59	Total weight of Transformer in Kgs	NUMERIC
60	Rating of Lightning Arrestors and Make thereof (kV, kA)	TEXT
61	Reference Standard of Lightning Arrestors.	TEXT
62	Min. External Clearances of HV Bushing terminals between Ph to Ph (in mm )	NUMERIC
63	Min. External Clearances of HV Bushing terminals between Ph to E (in mm)	NUMERIC
64	Min. External Clearances of LV Bushing terminals between Ph to Ph (in mm)	NUMERIC
65	Min. External Clearances of LV Bushing terminals between Ph to E (in mm)	NUMERIC
66	The temperature shall in no case reach a value that will damage the core itself , other parts or adjacent materials (Yes/No)	BOOLEAN

67	Type of Core (stacked/ wound)	TEXT
68	Core material used & its grade	TEXT
69	Thickness of core lamination in mm	NUMERIC
70	No of steps used in CRGO Core	NUMERIC
71	Diameter of the core (in mm)	NUMERIC
72	Effective Core Area ( Sq. cm)	NUMERIC
73	Flux density at normal voltage and frequency in Tesla	NUMERIC
74	Material of H.V. Winding	TEXT
75	Material of L.V. Winding	TEXT
76	Size/diameter of conductor used for HV winding in mm	NUMERIC
77	Total cross section area of HV Winding in sq mm.	NUMERIC
78	Size of strip used for LV winding conductor in mm	TEXT
79	Total cross section of Copper used in LV Winding in sq. mm	NUMERIC
80	No. of conductors in parallel for LV winding	NUMERIC
81	Current density of HV winding , in Amps/sq. mm.	NUMERIC
82	Current density of LV winding, in Amps / sq.mm.	NUMERIC
83	No of HV winding Turns	NUMERIC
84	No of LV winding Turns	NUMERIC
85	No of H.V. coils /phase	NUMERIC
86	No. of L.V. coils/phase	NUMERIC
87	Resistance of HV winding at 20 ° C in Ohm/phase	TEXT
88	Resistance of LV winding at 20 ° C in Ohm/phase	TEXT
89	% impedance value at 75° C	TEXT
90	Name of manufacturers of oil	TEXT
91	Grade of Oil	TEXT
92	A. Minimum volume of oil in liters as per tech. specification	NUMERIC
93	B. Quantity of total oil absorption (in Ltrs) in first filling	NUMERIC
94	Total oil Volume including Total Oil absorption in liters i.e. (A+B)	NUMERIC
95	Breakdown value of oil at the time of first filling (KV/mm) considering 2.5 mm gap	TEXT
96	Total volume of conservator shall be such as to content 10% of total quantity of oil (Yes/No)	BOOLEAN
97	No load losses at rated voltage and frequency in Watts	NUMERIC
98	Max. Total losses (No load loss + Load Loss) at 50 % loading in Watts at 75°C	NUMERIC
99	Max. Total losses (No load loss + Load Loss) at 100 % loading in Watts at 75°C	NUMERIC
100	Magnetizing current (No load) in Amps & its % of full load current & rated voltage referred to LV side	TEXT
101	Magnetizing current (No load) in amps & its % of full load current at maximum voltage (112.5% of rated voltage ) referred to LV side	TEXT

102	Min Clearance between Core & L.V. in mm	NUMERIC
103	MinClearances between L.V. & H.V. in mm	NUMERIC
104	Min Clearances between winding to body of tank in mm	NUMERIC
105	Min Clearance between HV phase to phase in mm	NUMERIC
106	Min Clearances between end insulation to Earth in mm	NUMERIC
107	Insulation materials provided for core	TEXT
108	Insulation materials provided for H.V. Conductor	TEXT
109	Insulation materials provided for L.V. Conductor	TEXT
110	Thickness of locking spacers between HV coils in mm	NUMERIC
111	Inter layer insulation provided in H.V winding to design for Top & bottom layer	TEXT
112	Inter layer insulation provided in L.V winding to design for Top & bottom layer	TEXT
113	Inter layer insulation provided in between all layer in H.V winding	TEXT
114	Inter layer insulation provided in between all layer in L.V winding	TEXT
115	Details of end insulation (thickness in mm)	NUMERIC
116	Whether wedges are Provided at 50% turns of the Coil (Yes/ No)	BOOLEAN
117	Thickness of insulating paper	NUMERIC
118	Regulation at 0.8 P.F. lag ( in %)	TEXT
119	Regulation at 0.8 P.F. leading ( in %)	TEXT
120	Regulation at unity P.F.. (in %)	TEXT
121	Reference standard of Bushing	TEXT
122	Material of HV and L.V Bushings	TEXT
123	Makes of HV and L.V Bushings	TEXT
124	Rating of HV Bushing ( in KV,A)	TEXT
125	Rating of LV Bushing (in KV,A)	TEXT
126	Minimum Creepage Distance of HV Bushings in mm (min 25mm/kV)	NUMERIC
127	Minimum Creepage Distance of LV Bushings in mm (min 25mm/kV)	NUMERIC
128	Power frequency withstand voltage dry & wet in kV(rms) for HV Bushings	NUMERIC
129	Dry lightning impulse withstand voltage test in kV (Peak) stating the waveform adopted for HV Bushing.	NUMERIC
130	Separate source power frequency withstand test for HV for 1minute in kV(min)	NUMERIC
131	Separate source power frequency withstand test for LV for 1minute in kV(min)	NUMERIC
132	Induced over voltage withstand test for 1 min. specify voltage frequency, time for test.	TEXT
133	Impulse test value (in kVp) .	NUMERIC
134	Efficiency at 75 ° C at unity P.F. at 125 % Load	NUMERIC
135	Efficiency at 75 ° C at unity P.F at 100 % Load	NUMERIC
136	Efficiency at 75 ° C at unity P.F. at 75 % Load	NUMERIC

137	Efficiency at 75 ° C at unity P.F. at 50 % Load	NUMERIC
138	Efficiency at 75 ° C at 0.8 P.F. lag at 125 % Load	NUMERIC
139	Efficiency at 75 ° C at 0.8 P.F. lag at 100 % Load	NUMERIC
140	Efficiency at 75 ° C at 0.8 P.F. lag at 75 % Load	NUMERIC
141	Efficiency at 75 ° C at 0.8 P.F. lag at 50 % Load	NUMERIC
142	Efficiency at 75 ° C at 0.8 P.F. lag at 25 % Load	NUMERIC
143	Efficiency at 75 ° C at 0.8 P.F. leading at 125 % Load	NUMERIC
144	Efficiency at 75 ° C at 0.8 P.F. leading at 100 % Load	NUMERIC
145	Efficiency at 75 ° C at 0.8 P.F. leading at 75 % Load	NUMERIC
146	Efficiency at 75 ° C at 0.8 P.F. leading at 50 % Load	NUMERIC
147	Efficiency at 75 ° C at 0.8 P.F. leading at 25 % Load	NUMERIC
148	The test certificates of copper conductors, core , insulating paper, porcelain Bushings,steel plate used for enclosure of the offered transformer are enclosed with the offer (Yes/No)	BOOLEAN
149	All type test report carried out on transformer at NABL laboratory shall be submitted along with the offer as per cl. XXII (c) of Section (I) i.e. Instructions to tenderers. (Yes/No). Firm may attach online.	BOOLEAN
150	Unbalance current test, Air pressure test and temperature rise test shall be conducted as per format enclosed with the technical specification along with the offer (Yes/ No)	BOOLEAN
151	All drawings shall be furnished for each offered item separately along with this offer(Yes/ No)	BOOLEAN
152	Oil absorption calculation sheet shall be furnished for each offered item separately along with this offer (Yes/ No)	BOOLEAN
153	Heat dissipation calculation shall be furnished for each offered item separately along with this offer (Yes/ No)	BOOLEAN
154	Calculation sheet submitted for Flux density calculations (stating HV & LV turns) for each offered item separately along with the offer (Yes/No)	BOOLEAN
155	Calculation sheet for 112% of rated V/f ratio (Over fluxing) calculation sheet shall be furnished for each item separately along with this offer (Yes/No)	BOOLEAN
156	Required documents, plant and machinery, testing equipment , list of order executed/under execution shall be furnished for each offered item separately along with this offer (Yes/ No)	BOOLEAN
157	The information required under Quality Assurance shall be submitted with the offer in physical format & soft copy(Yes/ No)	BOOLEAN
158	The cost data in the prescribed format shall be submitted with offer in physical format & soft copy (Yes/ No)	BOOLEAN
159	The performance Guarantee of the transformers in years	TEXT
160	Dimensions in mm of Air filled HV Cable Box provided suitable for 3 Core XLPE cables up to 300 sq.mm with gland plates as per tech spec. cl.no.13.8	TEXT
161	Dimensions in mm of Air filled LV Cable Box provided suitable for single core 400 sq.mm cable i.e. 3 cable run/ phase and 1cablerun for neutral for ore XLPE cables up to 300 sq.mm with gland plates as per tech spec. cl.no.13.8	TEXT
162	HV and LV cable Boxes provided shall be rectangular , M.S.Sheet of 2 mm , weather , vermin, and dustproof	TEXT
163	LV Cable Box shall be provided non magnetic gland plates	BOOLEAN

164	BEE label on transformer body provided (Yes/No)	TEXT
-----	-------------------------------------------------	------

630KVA,22/0.4KV3phDT/ID/CRGO/Star2/EEL-2/5yGP

GTP Order Sequence	GTP Parameters	Date Type
1	Name of Manufacturer	TEXT
2	Reference Standards	TEXT
3	Rating of Transformer in KVA	NUMERIC
4	Primary voltage in kV	NUMERIC
5	Secondary voltage in kV	TEXT
6	Transformer shall be Oil Natural Air Natural (ONAN) type Yes/No	BOOLEAN
7	Transformer shall be suitable for Indoor application. (Yes/No)	BOOLEAN
8	Highest System Voltage in kV	NUMERIC
9	Frequency in HZ.	TEXT
10	Transformer shall be suitable for solid neutral earthing (Yes/No)	BOOLEAN
11	Service condition shall be applicable as per Technical specification	BOOLEAN
12	Transformer Colour as per IS:5	TEXT
13	Type of connection for H.V. Winding (Delta) (Yes/No).	TEXT
14	Type of connection for L.V. Winding (Star) (Yes/No)	TEXT
15	Vector Group Dyn-11 (Yes/No)	TEXT
16	Name Plate details are as per the requirement specified in tender (Yes/No)	BOOLEAN
17	Thickness of Name plate (in SWG)	NUMERIC
18	Maximum temperature rise of Windings over an Ambient temp. of 50°C in °C	NUMERIC
19	Maximum temperature rise of oil over an Ambient temp. of 50°C in °C	NUMERIC
20	Approximate overall length of the Transformer in mm	NUMERIC
21	Approximate overall breadth of the Transformer in mm	NUMERIC
22	Approximate overall height of the Transformer in mm	NUMERIC
23	Approximate length of the Transformer tank in mm	NUMERIC
24	Approximate breadth of the Transformer tank in mm	NUMERIC
25	Approximate height of the Transformer tank in mm	TEXT
26	Thickness of the side of transformer tank plates in mm	NUMERIC
27	Thickness of the bottom of transformer tank plates in mm	NUMERIC
28	Thickness of the top of transformer tank plates in mm	NUMERIC
29	Size of reinforced welded angle to the Transformer Tank in mm.	TEXT
30	Degree of slope to the top plate of Transformer.	TEXT

31	Shape of transformer Tank	TEXT
32	Type of Tank (Corrugated/ Conventional)	TEXT
33	In case of corrugated tank, thickness of corrugated sheet (in mm)	TEXT
34	Size of Transformer Base Channel in mm.	TEXT
35	Size (diameter & width) and No. of Rollers provided to the Transformer	TEXT
36	Conservator tank to the transformer with oil level indicator (showing three levels) and drain plug is provided ( Yes/ No)	BOOLEAN
37	Dimensions of conservator Tank (LxD) in mm	TEXT
38	Drain Valve size (32 mm) provided to the transformer tank ( Yes/No)	NUMERIC
39	Size of Oil filling hole with cap in mm. (on conservator) is provided.	NUMERIC
40	Size of filter valve in mm. is provided.	NUMERIC
41	No. & Size in mm of Lifting lugs provided to transformer	TEXT
42	No. & Size in mm of pulling lugs provided to transformer	TEXT
43	No. & Size in mm of transformer top cover lifting lugs provided to transformer	TEXT
44	No. of Earthing terminals with suitable size in (SWG)	TEXT
45	Thermometer pocket is provided (Yes/No)	BOOLEAN
46	Quantity of Silica-Gel filled in breather ( in gm) & make of breather	TEXT
47	Explosion vent with diaphragm. (Yes/No)	BOOLEAN
48	No of radiators both on HV & LV side provided and location with arrangement & size.	TEXT
49	Thickness of the radiator of transformer in mm. and fin size	TEXT
50	No of radiator fins.	NUMERIC
51	(A) Radiating surface of radiators in Sq. Mtrs	NUMERIC
52	(B) Radiating surface of Tank only in Sq. Mtrs.	NUMERIC
53	Total radiating surface of transformer tank in Sq. mtrs.	NUMERIC
54	Weight of Core in kgs	NUMERIC
55	Weight of copper (Winding) in Kgs.	NUMERIC
56	Weight of Transformer Tank with fittings in Kgs.	NUMERIC
57	Weight of Oil in kgs	NUMERIC
58	Volume of Oil in Ltrs	NUMERIC
59	Total weight of Transformer in Kgs	NUMERIC
60	Rating of Lightening Arrestors and Make thereof (kV, kA)	TEXT
61	Reference Standard of Lightening Arrestors.	TEXT
62	Min. External Clearances of HV Bushing terminals between Ph to Ph (in mm )	NUMERIC
63	Min. External Clearances of HV Bushing terminals between Ph to E (in mm)	NUMERIC
64	Min. External Clearances of LV Bushing terminals between Ph to Ph (in mm)	NUMERIC
65	Min. External Clearances of LV Bushing terminals between Ph to E (in mm)	NUMERIC

66	The temperature shall in no case reach a value that will damage the core itself , other parts or adjacent materials (Yes/No)	BOOLEAN
67	Type of Core (stacked/ wound)	TEXT
68	Core material used & its grade	TEXT
69	Thickness of core lamination in mm	NUMERIC
70	No of steps used in CRGO Core	NUMERIC
71	Diameter of the core (in mm)	NUMERIC
72	Effective Core Area ( Sq. cm)	NUMERIC
73	Flux density at normal voltage and frequency in Tesla	NUMERIC
74	Material of H.V. Winding	TEXT
75	Material of L.V. Winding	TEXT
76	Size/diameter of conductor used for HV winding in mm	NUMERIC
77	Total cross section area of HV Winding in sq mm.	NUMERIC
78	Size of strip used for LV winding conductor in mm	TEXT
79	Total cross section of Copper used in LV Winding in sq. mm	NUMERIC
80	No. of conductors in parallel for LV winding	NUMERIC
81	Current density of HV winding , in Amps/sq. mm.	NUMERIC
82	Current density of LV winding, in Amps / sq.mm.	NUMERIC
83	No of HV winding Turns	NUMERIC
84	No of LV winding Turns	NUMERIC
85	No of H.V. coils /phase	NUMERIC
86	No. of L.V. coils/phase	NUMERIC
87	Resistance of HV winding at 20 ° C in Ohm/phase	TEXT
88	Resistance of LV winding at 20 ° C in Ohm/phase	TEXT
89	% impedance value at 75° C	TEXT
90	Name of manufacturers of oil	TEXT
91	Grade of Oil	TEXT
92	A. Minimum volume of oil in liters as per tech. specification	NUMERIC
93	B. Quantity of total oil absorption (in Ltrs) in first filling	NUMERIC
94	Total oil Volume including Total Oil absorption in liters i.e. (A+B)	NUMERIC
95	Breakdown value of oil at the time of first filling (KV/mm) considering 2.5 mm gap	TEXT
96	Total volume of conservator shall be such as to content 10% of total quantity of oil (Yes/No)	BOOLEAN
97	No load losses at rated voltage and frequency in Watts	NUMERIC
98	Max. Total losses (No load loss + Load Loss) at 50 % loading in Watts at 75°C	NUMERIC
99	Max. Total losses (No load loss + Load Loss) at 100 % loading in Watts at 75°C	NUMERIC
100	Magnetizing current (No load) in Amps & its % of full load current & rated voltage referred to LV side	TEXT

101	Magnetizing current (No load) in amps & its % of full load current at maximum voltage (112.5% of rated voltage ) referred to LV side	TEXT
102	Min Clearance between Core & L.V. in mm	NUMERIC
103	MinClearances between L.V. & H.V. in mm	NUMERIC
104	Min Clearances between winding to body of tank in mm	NUMERIC
105	Min Clearance between HV phase to phase in mm	NUMERIC
106	Min Clearances between end insulation to Earth in mm	NUMERIC
107	Insulation materials provided for core	TEXT
108	Insulation materials provided for H.V. Conductor	TEXT
109	Insulation materials provided for L.V. Conductor	TEXT
110	Thickness of locking spacers between HV coils in mm	NUMERIC
111	Inter layer insulation provided in H.V winding to design for Top & bottom layer	TEXT
112	Inter layer insulation provided in L.V winding to design for Top & bottom layer	TEXT
113	Inter layer insulation provided in between all layer in H.V winding	TEXT
114	Inter layer insulation provided in between all layer in L.V winding	TEXT
115	Details of end insulation (thickness in mm)	NUMERIC
116	Whether wedges are Provided at 50% turns of the Coil (Yes/ No)	BOOLEAN
117	Thickness of insulating paper	NUMERIC
118	Regulation at 0.8 P.F. lag ( in %)	TEXT
119	Regulation at 0.8 P.F. leading ( in %)	TEXT
120	Regulation at unity P.F.. (in %)	TEXT
121	Reference standard of Bushing	TEXT
122	Material of HV and L.V Bushings	TEXT
123	Makes of HV and L.V Bushings	TEXT
124	Rating of HV Bushing ( in KV,A)	TEXT
125	Rating of LV Bushing (in KV,A)	TEXT
126	Minimum Creepage Distance of HV Bushings in mm (min 25mm/kV)	NUMERIC
127	Minimum Creepage Distance of LV Bushings in mm (min 25mm/kV)	NUMERIC
128	Power frequency withstand voltage dry & wet in kV(rms) for HV Bushings	NUMERIC
129	Dry lightning impulse withstand voltage test in kV (Peak) stating the waveform adopted for HV Bushing.	NUMERIC
130	Separate source power frequency withstand test for HV for 1minute in kV(min)	NUMERIC
131	Separate source power frequency withstand test for LV for 1minute in kV(min)	NUMERIC
132	Induced over voltage withstand test for 1 min. specify voltage frequency, time for test.	TEXT
133	Impulse test value (in kVp) .	NUMERIC
134	Efficiency at 75 ° C at unity P.F. at 125 % Load	NUMERIC

135	Efficiency at 75 ° C at unity P.F at 100 % Load	NUMERIC
136	Efficiency at 75 ° C at unity P.F. at 75 % Load	NUMERIC
137	Efficiency at 75 ° C at unity P.F. at 50 % Load	NUMERIC
138	Efficiency at 75 ° C at 0.8 P.F. lag at 125 % Load	NUMERIC
139	Efficiency at 75 ° C at 0.8 P.F. lag at 100 % Load	NUMERIC
140	Efficiency at 75 ° C at 0.8 P.F. lag at 75 % Load	NUMERIC
141	Efficiency at 75 ° C at 0.8 P.F. lag at 50 % Load	NUMERIC
142	Efficiency at 75 ° C at 0.8 P.F. lag at 25 % Load	NUMERIC
143	Efficiency at 75 ° C at 0.8 P.F. leading at 125 % Load	NUMERIC
144	Efficiency at 75 ° C at 0.8 P.F. leading at 100 % Load	NUMERIC
145	Efficiency at 75 ° C at 0.8 P.F. leading at 75 % Load	NUMERIC
146	Efficiency at 75 ° C at 0.8 P.F. leading at 50 % Load	NUMERIC
147	Efficiency at 75 ° C at 0.8 P.F. leading at 25 % Load	NUMERIC
148	The test certificates of copper conductors, core , insulating paper, porcelain Bushings, steel plate used for enclosure of the offered transformer are enclosed with the offer (Yes/No)	BOOLEAN
149	All type test report carried out on transformer at NABL laboratory shall be submitted along with the offer as per cl. XXII (c) of Section (I) i.e. Instructions to tenderers. (Yes/No). Firm may attach online.	BOOLEAN
150	Unbalance current test, Air pressure test and temperature rise test shall be conducted as per format enclosed with the technical specification along with the offer (Yes/ No)	BOOLEAN
151	All drawings shall be furnished for each offered item separately along with this offer(Yes/ No)	BOOLEAN
152	Oil absorption calculation sheet shall be furnished for each offered item separately along with this offer (Yes/ No)	BOOLEAN
153	Heat dissipation calculation shall be furnished for each offered item separately along with this offer (Yes/ No)	BOOLEAN
154	Calculation sheet submitted for Flux density calculations (stating HV & LV turns) for each offered item separately along with the offer (Yes/No)	BOOLEAN
155	Calculation sheet for 112% of rated V/f ratio (Over fluxing) calculation sheet shall be furnished for each item separately along with this offer (Yes/No)	BOOLEAN
156	Required documents, plant and machinery, testing equipment , list of order executed/under execution shall be furnished for each offered item separately along with this offer (Yes/ No)	BOOLEAN
157	The information required under Quality Assurance shall be submitted with the offer in physical format & soft copy(Yes/ No)	BOOLEAN
158	The cost data in the prescribed format shall be submitted with offer in physical format & soft copy (Yes/ No)	BOOLEAN
159	The performance Guarantee of the transformers in years	TEXT
160	Dimensions in mm of Air filled HV Cable Box provided suitable for 3 Core XLPE cables up to 300 sq.mm with gland plates as per tech spec. cl.no.13.8	TEXT
161	Dimensions in mm of Air filled LV Cable Box provided suitable for single core 400 sq.mm cable i.e. 3 cable run/ phase and 1 cablerun for neutral for ore XLPE cables up to 300 sq.mm with gland plates as per tech spec. cl.no.13.8	TEXT
162	HV and LV cable Boxes provided shall be rectangular , M.S.Sheet of 2 mm , weather , vermin, and dustproof	TEXT

163	LV Cable Box shall be provided non magnetic gland plates	BOOLEAN
164	BEE label on transformer body provided (Yes/No)	TEXT

### Required Documents (To be uploaded online)

Sr. No.	NAME	SECTION	ITEM	DESCRIPTION
1	BEE certificate	Technical Section	630KVA,11/0.4K V3phDT/ID/C	Upload Valid BEE certificate or necessary documentary proof of having applied for renewal of validity of the BEE certificate as per clause no XIV.
2	Type test certificate	Technical Section	630KVA,11/0.4K V3phDT/ID/C	Upload Valid Type test certificates from NABL accredited lab such as CPRI / ERDA
3	BIS License	Technical Section	630KVA,11/0.4K V3phDT/ID/C	Upload Valid BIS License or necessary documentary proof of having applied for renewal of validity of the BIS license as per clause no XIV
4	Type test certificate	Technical Section	630KVA,22/0.4K V3phDT/ID/C	Upload Valid Type test certificates from NABL accredited lab such as CPRI / ERDA
5	BIS License	Technical Section	630KVA,22/0.4K V3phDT/ID/C	Upload Valid BIS License or necessary documentary proof of having applied for renewal of validity of the BIS license as per clause no XIV
6	BEE certificate	Technical Section	630KVA,22/0.4K V3phDT/ID/C	Upload Valid BEE certificate or necessary documentary proof of having applied for renewal of validity of the BEE certificate as per clause no XIV.
7	Power of attorney	Commercial Section		Power of attorney
8	Certificate for No Deviation as per attached Format-5	Commercial Section		Certificate for No Deviation as per attached Format-5
9	Profit & Loss statement and Balance sheet for last 3 FYs	Commercial Section		Profit & Loss statement and Balance sheet for last 3 FYs
10	Copies of orders executed by the bidder and the Certificate from the purchaser / Electricity Distrib	Commercial Section		Copies of orders executed by the bidder and the Certificate from the purchaser / Electricity Distribution Utility, Electricity Distribution Franchisee, Public Sector Undertaking for supply of quantity
11	Order Completion certificate from Electricity Distribution Utility, Electricity Distribution Franchi	Commercial Section		Order Completion certificate from Electricity Distribution Utility, Electricity Distribution Franchisee, Public Sector Undertaking or Documentary evidence for supply of material to Electricity Distrib
12	Offered quantity and delivery schedule on bidders letter head.	Commercial Section		Offered quantity and delivery schedule on bidders letter head.
13	List of in house manufacturing and testing facilities as well as quality control set up	Commercial Section		List of in house manufacturing and testing facilities as well as quality control set up
14	Documentary evidence showing annual turnover of last 3 years, certified by Chartered Accountant for	Commercial Section		Documentary evidence showing annual turnover of last 3 years, certified by Chartered Accountant for preceding three financial years. (As per attached Format-4)
15	List of orders in hand certified by Chartered Engineer/accountant	Commercial Section		List of orders in hand certified by Chartered Engineer/accountant

Sr. No.	NAME	SECTION	ITEM	DESCRIPTION
16	ISO certification for quality management system & environmental management system	Commercial Section		ISO certification for quality management system & environmental management system
17	Documentary evidence in respect of classification of your unit as per Micro, Small and Medium	Commercial Section		UDYAM Certificate
18	Manufacturing Capacity	Commercial Section		Upload Documentary evidence (e.g. SSI/NSIC/CA Certificate) for manufacturing capacity to cover the quantity offered.
19	EMD receipt / E Bank Guarantee only	Commercial Section		EMD receipt / E Bank Guarantee only
20	GST registration certificate.	Commercial Section		GST registration certificate.
21	Self-undertaking on bidders letter head for not approaching any one for undue influence as per attac	Commercial Section		Self-undertaking on bidders letter head for not approaching any one for undue influence as per attached Format-2.
22	Annexure-I regarding declaration along with the bid that bidder is not blacklisted/ debarred	Commercial Section		Annexure-I regarding declaration along with the bid that bidder is not blacklisted/ debarred
23	Corrupt & Fraudulent Practice declaration	Commercial Section		Upload Corrupt & Fraudulent Practice declaration as per tender terms and condition.
24	Certificate from Chartered Accountant for not having controlling stake in more than one entity	Commercial Section		Certificate from Chartered Accountant for not having controlling stake in more than one entity as per attached Format-3.
25	Annexure-F regarding declaration of legal litigations.	Commercial Section		Annexure-F regarding declaration of legal litigations.