

MATERIAL SPECIFICATIONS CELL

TECHNICAL SPECIFICATION FOR STRAIGHT THROUGH/TERMINATIONS/TRANSITION
JOINTING KITS FOR HT LT ARMoured PVC / XLPE ALUMINIUM /COPPER CONDUCTOR CABLES

STRAIGHT THROUGH/TERMINATIONS/TRANSITION JOINTING KITS FOR HT LT ARMoured
PVC / XLPE ALUMINIUM /COPPER CONDUCTOR CABLES

INDEX

SN	Particulars
1	Scope
2	Application
3	Service Conditions
4	Applicable Standards
5	General Technical Requirement
	5.01 Heat Shrinkable Straight through joints for MV Cable.
	5.02 Heat Shrinkable Termination for MV Cables
	5.03 Cold Shrinkable Straight through Joints for LV Cable:
	5.04 Cold Shrinkable Termination.
	5.05 1.1kV Joints for Armour, XLPE,Aluminium/Copper Conductor cable:
6.0	Marking and labeling
7.0	Type tests
8.00	Type test sequence
9.00	Pre despatch inspection
10.00	Inspection after receipt at stores
11.00	Demonstration & Training
12.00	Guarantee
13.00	Quality Control
14.00	Packing
15.00	Tender Sample
16.00	Schedule
	A1) GTP for HT cable accessories ie joints & terminations(heat shrinkable)
	<u>A2) GTP for HT cable accessories ie joints & terminations</u>
	A3) GTP for LT cable accessories ie joints & terminations(heat shrinkable)
	A4) GTP for LT cable accessories ie joints & terminations (cold shrinkable/mechanical types)
17.00	Indicative Drawings

TECH. SPEC NO. CE/T&QC/MSC/HT LT STRAIGHT THROUGH , TREMINATIONAND TRANSTION
JOINTS /2021, Date: 15.02.2021

1.00 SCOPE

This specification covers design, manufacturing, testing, supply of IS Mark (IS-13573:2011) HT/LT Cable accessories i.e Joints/Termination (straight through, stop ends and transition joints for dissimilar cables etc.) suitable for armoured, PVC/XLPE, Aluminum/Copper conductor cables.

The cable accessories shall conform in all respects to high standards of engineering, design and workmanship and shall be capable of performing in continuous commercial operation, in a manner acceptable to purchaser, who will interpret the meaning of drawings and specification and shall have the power to reject any work or material which, in his judgment is not in accordance therewith. The offered material shall be complete with all components necessary for their effective and trouble free operation. Such components shall be deemed to be within the scope of Bidder's supply irrespective of whether those are specifically brought out in these specifications and or the commercial order or not.

2.00 APPLICATION

The cable accessories shall be use on armoured, PVC/XLPE, LT/HT, Aluminum/Copper conductors cables installed in sub-stations for power distribution system and LT/HT consumers.

3.00 SERVICE CONDITIONS

The cable accessories to be supplied against this specification shall be suitable for continuous operation under the following tropical conditions .

Environmental Conditions

- | | |
|---|-----------------------|
| a) Maximum ambient temperature | 50 ⁰ C |
| b) Maximum ambient temperature in shade | 45 ⁰ C |
| c) Minimum temperature of air in shade | 35 ⁰ C |
| d) Maximum daily average temperature | 40 ⁰ C |
| e) Maximum yearly weighted average temperature | 32 ⁰ C |
| f) Relative Humidity | 10 to 95 % |
| g) Maximum Annual rainfall | 1450 mm |
| h) Maximum wind pressure | 150 Kg/m ² |
| i) Maximum altitude above mean sea level | 1000 meters |
| j) Isoceraunic level | 50 days/years |
| k) Seismic level (Horizontal acceleration) | 0.3 g |
| l) Climate: Moderately hot and humid tropical climate conducive to rust and fungus growth and polluted with industrial pollution. | |

4.00 APPLICABLE STANDARDS

IS-13573 (Part -I):2011 – for working voltage from 1.1kV upto and including 3.3kV (E) - Test methods and requirements.(for Type Test Only)

IS-13573 (Part-II):2011 - for working voltage from 3.3kV (UE) upto and including 33kV (E) – Test requirements. (for Type Test Only)

IS-13573(Part-III):2011 – for working voltage from 3.3kV (UE) upto and including 33kV (E) – Test methods. (for Type Test Only)

IEC: 60502-04:2010/ 2005, VDE 0278 – Standard for cable accessories. IEEE48 –for terminations of cable. (for Type Test Only)

ENA-09-13 standards – for components used in the Kit (From 1kV (E) to 36 kV (E))

ENA-09-11 standards – for components used in the Kit (From 600V (E) to 1 kV (E))

The specification given in this documents supersedes the relevant clauses of IS-13573:2011 (Part-I/II/III) wherever applicable.

5.00 GENERAL TECHNICAL REQUIREMENT

Material used for construction of a joint/termination shall perfectly match with the di-electric, chemical and physical characteristics of the associated cable. The material and design concepts shall incorporate a high degree of operating compatibility between the cable and joints.

The Straight through joint kit or termination shall be complete with all accessories, jointing material, insulating stress control and sealing material, lugs, etc. as well as an instruction booklet explaining the method of using the kit. In case of heat shrinkable type kit, the joint shall include a heat shrinkable dual wall tubing which shall be insulating from inside and semi conductive from outside. Detailed sectional views of the assemblies shall be submitted along with the offer.

The straight through joints should be absolutely impervious to the entry of water. The manufacturer shall use the proven technologies and design to ensure a construction which will prevent entry of water or any other liquid inside the straight through joint and cable.

The cable termination kit shall be suitable for terminating the cable on indoor or outdoor installation as per requirement. The type of cable will be armoured, PVC / XLPE insulated H.T/L.T. Cables

The Straight - through joints shall be suitable for Buried / Over Head application.

The heat shrinkable component shall be light in weight and shall be made of specially formulated cross linked polymeric material with excellent

**STRAIGHT THROUGH/TERMINATIONS/TRANSITION JOINTING KITS FOR HT LT ARMoured
PVC / XLPE ALUMINIUM /COPPER CONDUCTOR CABLES**

tracking & erosion resistance characteristic. Environmentally sealed system for splicing dielectric shielded power cables.

The design of joint and termination shall be such that on completion of work, the cable can be charged immediately.

The joint/termination shall have range taking feature. The Connector/ferrule used shall be range taking, Moisture entry into conductor shall be protected by providing special mastic.

The termination kit offered shall provide for total environmental sealing of the cable crutch and at the lug end. The details of the same shall be submitted along with the offer

Indoor Termination: HT/LT Jointing kit should be designed to withstand high humidity and surface contamination under electrical stress caused due to condensation and dust in indoor conditions.

Outdoor Terminations: LT/HT Terminations should be designed to withstand exposure to extreme climatic variations & surface contamination, UV rays from sunlight and electrical stress caused due to heavy pollution & dust in external conditions.

The following HT/LT Armoured PVC /XLPE Aluminum/Copper conductor cables of sizes/ rating are generally used in MSEDCL network and suitable to these cables, straight through joints & cable termination kits shall be supplied.

Sr. No	3.5 Core L.T Cable	1 Core L.T. Cable	3 Core H.T Cable
1	35 SQMM,	35 SQMM,	95 SQMM
2	50 SQMM	50 SQMM	120 SQMM
3	70 SQMM	70 SQMM	150 SQMM
4	95 SQMM	95 SQMM	185 SQMM
5	120 SQMM	120 SQMM	240 SQMM
6	150 SQMM	150 SQMM	300 SQMM
7	185 SQMM	185 SQMM	400 SQMM
8	240 SQMM	240 SQMM	500 SQMM
9	300 SQMM	300 SQMM	630 SQMM
10	400 SQMM	400 SQMM	-

5.01 Heat Shrinkable Straight through joints for MV Cable.

The heat shrinkable straight through joints shall have following function abilities .

- a) For encapsulation and environmental sealing, heat shrink wraparound sleeves with hot melt adhesive coating are required to be provided along with 304 grade Stainless Steel channels for locking the sleeve. The bidder should submit certificate to confirm grade for stainless steel channels.

STRAIGHT THROUGH/TERMINATIONS/TRANSITION JOINTING KITS FOR HT LT ARMoured
PVC / XLPE ALUMINIUM /COPPER CONDUCTOR CABLES

b) To Reduce stress over conductor, heat shrinkable stress control tube to be provided. The stress control tube has to be in electrical contact with the outer insulation screen of the cable. Impedance of the tube shall be constant up to an operating temperature and shall be within the range 1×10^8 ohm-cm to 8×10^8 ohm-cm and with relative permittivity shall be minimum 15. Voids filling and stress relief over crimped connector and cut point of the insulation screen to be provided with void filling and moisture sealing high permittivity stress grading mastic and lubricant. The nested ends of the heat shrinkable tubing shall be provided with environmental sealing red mastic. Continuity of copper metallic screen of cable to be provided by Tinned copper mesh with 50% overlap. Mechanical protection of joint to be provided by Rollable Metallic Strip Canister or GI Wire mesh of suitable size and length for 3 core and by tinned copper mesh for 1 core cable.

c) For jointing of main conductor cores suitable size of crimp type ferrules/mechanical connectors with range taking feature should be provided. The cross-sectional area(CSA)of the ferrule/mechanical connector shall not be less than CSA of the conductor of the cable. Length of the ferrule/connector shall be sufficient to allow adequate number of crimps/shear head type bolts, to limit temperature rise at the joint. For providing insulation over the conductor area maximum three layers of heat shrinkable insulating tube are to be provided (including stress control tube, Insulating tube and Dual Wall tube). The thickness of the heat shrinkable tubes after installation should not be less than 1.2 times the insulation thickness of the cable. For outer semi conductor screening of the joint suitable heat shrinkable dual wall tubes which are co-extruded are to be provided

d) Earth Continuity between armour to be provided by tinned copper braid of adequate cross section. This is required for proper earthing of the joint. Also, to support armour wire support ring is to be provided. The material of support ring to be steel (G.I.) for 3 core Cable and Aluminium for 1 core cable
- Worm drive clip(jubilee/hose clips) for tightly securing the earthing braid is required to be provided in suitable size & quantity.

e) For cleaning of cores, removing burrs on ferrules & rough insulation. Sufficient quantity of cleaning solvent & aluminium oxide cloth is required to be provided.

5.02 Heat Shrinkable Termination for MV Cables

- (a) The cable termination (Indoor & Outdoor) shall be of class-I type which consist of following point.
- i) stress control layer
 - ii) non-tracking tubing Resistant to UV light and which provides environmental protection.
 - iii) moisture seal-for environmental sealing against ingress of moisture & aggressive gases.
- (b) for crutch portion sealing of cables trifurcating Heat shrinkable break out is required.
- (c) To protect the cable breakout mono plast tape/non-adhesive PVC tape/black mastic is required to be applied over earthing arrangement(worm drive clip installed over copper braid and armour) for suitable length of the termination part.

**STRAIGHT THROUGH/TERMINATIONS/TRANSITION JOINTING KITS FOR HT LT ARMoured
PVC / XLPE ALUMINIUM /COPPER CONDUCTOR CABLES**

- (d) for proper sealing of Lugs at end of the termination suitable size & length of Heat Shrinkable tube is to be provided. No tape is to be provided for sealing purpose. For earthing tinned copper braid of adequate cross section is to be provided. To support armour wire GI support ring is to be provided. Worm drive clip (jubilee clips) for tightly securing the earthing braid is required to be provided in suitable size & quantity.
- (e) Suitable size of heat shrinkable stress control tubes is to be provided to reduce stress at cut back of screen. Void filling stress grading mastic is to be provided at semi-conducting screen. Heat shrinkable anti tracking tubes are to be provided to cover bare XLPE insulation and to provide UV resistance & environmental sealing. Anti tracking tubes shall have non-tracking adhesive coating inside, for a length of 50-60 mm on both ends.
- (f) for cleaning of cores, removing burrs on ferrules & rough insulation, sufficient quantity of cleaning solvent & aluminium oxide cloth is required to be provided. Adhesive tapes to be provided in sufficient length for marking on cables.
- g) For Indoor terminations, non-tracking tube of length 450 mm to be provided. For Outdoor terminations, non-tracking tube of length 650 mm to be provided. Suitable size and number of heat shrinkable rain sheds are to be provided to increase the creepage distance and to prevent water collection over termination end portion.
- i. Following is the recommended selection chart for Minimum Creepage distance (in mm) for rain water sheds:

Cable cross section	Voltage Level		
	11 kV	22 kV	33 kV
25 – 50 sq mm	70 mm	70 mm	85 mm
70 – 120 sq mm	70 mm	85 mm	105 mm
150 – 185 sq mm	70 mm	85 mm	105 mm
240 – 400 sq mm	85 mm	105 mm	115 mm
500 – 630 sq mm	85 mm	105 mm	115 mm

Note: 'Creepage distance' is defined as the length along the surface of the Creepage Extension Sheds.

- ii. Number of Creepage extension sheds per core as per IS 13573 (part I,II&III) :

Voltage Level	11 kV	22 kV	33 kV
No. of Sheds	2 Nos	3 Nos	4 Nos

5.03 Cold Shrinkable Straight through Joints for LV Cable:

The cold shrink straight through joint shall consist of following functional abilities:

- a) for encapsulation, environmental sealing & mechanical protection application of mastic coated vinyl tape and armor cast material is required.

- b) for joining of main conductor cores suitable size of ferrules/mechanical connectors are required also for shielding over connector semiconducting tape is required to be provided in suitable size & length.

STRAIGHT THROUGH/TERMINATIONS/TRANSITION JOINTING KITS FOR HT LT ARMoured
PVC / XLPE ALUMINIUM /COPPER CONDUCTOR CABLES

c) to reduce stress over conductor & moisture sealing over entire joint portion one piece body (splice assembly) made of silicon rubber is to be provided which has stress control, insulation and screen continuity property.

d) suitable size of copper braid is required for proper earthing for the joint. Also, to support armour GI solid collect & worm drive (jubilee clips) to tighten the earthing braid is required to be provided.

e) for rebuilding the insulation & making joint cold shrink splice bodies of suitable size (diameter & length) is required to be provided. The material of the joint (splice) body shall be of silicone which is factory expanded and placed on a removable core. The removing of the core causes the cold shrink joint body shall maintain a compressive force continuously throughout the life of product. This pressure will ensure a complete moisture seal.

f) for cleaning of cores, removing burns on ferrules & rough insulation sufficient quantity of cleaning liquid & aluminium oxide cloth is required to be provided.

5.04 Cold Shrinkable Termination.

(a) The cable termination (Indoor & Outdoor) shall be of class-I type which consist of following point

- i) stress control layer
- ii) Resistance against UV light environmental protection.
- iii) moisture seal-for environmental sealing against ingress of moisture & aggressive gases

b) for cruch portion sealing of ends trifurcating break out boot is required

c) To protect the boot mono plast tape/pvc tape is required to apply over armour for suitable length of the termination part.

d) for proper sealing of end termination suitable size & length silicon tape is required. Also to support armour GI solid collect & worm drive clips (jubilee clips) of suitable size to tighten earthing braid is required to be provided with semiconducting tape.

e) cold shrink termination bodies with stress control material is required to be provided to reduce the stress at cut back of screen & protect XLPE insulation against UV & environment. Also to feel the void parts at cut back portion suitable size & length semi conducting tape is required.

f) for cleaning of cores, removing burrs on ferrules & rough the insulations, sufficient quantity of cleaning liquid & aluminium oxide cloth is required to be provided. Also some pvc adhesive tapes to be provided in sufficient length for marking on cables.

g) sufficient quantity of suitable size rain sheds are to be provided to increase the creepage distance & prevent water collection over termination end portion.

5.05 1.1kV Joints for Armour, XLPE, Aluminium/Copper Conductor cable:

This specification covers design and manufacturing of heat shrinkable cable joints suitable for 1.1kV Armoured PVC/XLPE Al/Cu Conductor Cables.

1. The accessories shall be supplied in kit form. Each component of the kit shall carry the manufacturer's mark of origin.
2. The supplied joint shall have a range taking feature.
3. The kits must have unlimited shelf life.
4. For outer sealing of the joint, a suitable size of Heat Shrinkable wraparound sleeve with 304 grade Stainless Steel Channel shall be provided. The bidder should submit certificate to confirm grade for stainless steel channels.
5. Suitable size of Heat Shrinkable tubings are to be provided for shrinking over individual cores for protection against moisture and dust ingress.
6. Type tests should have been carried out to prove the general qualities and design of a given type of jointing system. This type of joint should have been tested as per IS 13573 Part I at CPRI, ERDA or any such NABL accredited lab. Type Test Report for the same shall be submitted along with offer.
7. For conductor connection, either crimp type ferrules or sheer head bolt mechanical connectors should be provided.
8. The connector should be range taking which can be used for both copper & Aluminium cables.
9. Armour Connectivity and mechanical protection shall be maintained by using sufficient quantity of GI Wire mesh
10. Sufficient cross section qty of Aluminum braid shall be provided for earthing purposes.
11. The design of joint shall be such that on completion of joint the cable can be charged immediately.

6.0 MARKING AND LABELING

As per the IS 13573 (Part-I&II):2011 all kits shall be marked and labeled suitably for identification.

- a. Manufacturer's name or logo and the name of components wherever feasible;
- b. Type of jointing materials, the application;
- c. Batch number(s), where relevant;
- d. Product reference;
- e. Defined storage conditions and expiry date, if any;

- f. If relevant, the manufacturing date;
- g. Health and safety marking and handling instructions, where relevant; and
- h. Reference to compliance with this standard.

7.0 TYPE TESTS

The Jointing Kit offered, shall be fully type tested at NABL Lab as per the relevant standards. The applicable standards are indicated in Clause No.4.00. The tenderer shall furnish the type test reports alongwith the offer. Offer without Type test reports will not be considered. The Type test reports not pertaining to the size/ratings cables mentioned in clause no 5 shall not be considered. For any change in the design/type, already type tested and the design/type offered against this specification the purchaser reserved the right to demand repetition of type tests without any extra cost in presence of purchaser' representative.

8.00 TYPE TEST SEQUENCE

The type test shall be carried out as per the test sequence given in IS 13573/2011(Part – I,II & III)

A. Acceptance & Routine Tests:

All acceptance and routine tests as stipulated in the relevant standards shall be carried out by the supplier in presence of purchaser's representative. The purchaser reserves the right to insist for witnessing the acceptance/routine testing of the bought out items.

B. Additional Tests:

Additional test to be carried out in M.S.E.D.C.L'S Lab are Volume Resistivity, B.D.V., Tensile & Elongation etc. Supplier may depute his representative for witnessing the test conforming the date from relevant M.S.E.D.C.L'S Lab.

9.00 PRE DESPATCH INSPECTION

All acceptance tests and inspection shall be carried out at the place of manufacturer unless otherwise specially agreed upon the manufacturer and purchase at the time purchase. Manufacturer shall offer to the inspector representing the purchaser, all the reasonable facilities, free of charge, for inspection and testing to satisfy him that the material is being supplied in accordance with this specification. The MSEDCL

STRAIGHT THROUGH/TERMINATIONS/TRANSITION JOINTING KITS FOR HT LT ARMoured PVC / XLPE ALUMINIUM /COPPER CONDUCTOR CABLES

representative/Engineer attending the above test will carried out testing for suitable number of cable joints/terminations as per sampling procedure laid down in IS:13573(Part-I,II,III):2011 (amended up to date) and issue test certificate approval to the manufacturer and give clearance for dispatch. The cable jointing/termination kit shall be sealed after the inspection.

10.00 INSPECTION AFTER RECEIPT AT STORES

For Random sample testing (RST) the sample Cable Termination/jointing kit will be drawn from any one of the store.

11.00 DEMONSTRATION & TRAINING :

The purchaser reserves the right to ask for demonstration of the equipment offered at the purchasers place. The Tenderer shall arrange for demonstration of installation of jointing/termination kits free of cost for giving training to purchasers representative to get acquainted with the jointing method. The jointing/termination kit along with required length of the kits to be used for demonstration purpose shall be specified the cable will be provided by the Purchaser.

12.00 GUARANTEE

The Kits shall be suitable for storage without deteriorating at a temperature upto 50°C under normal conditions of storage and shall have unlimited shelf storage life. The tenderer shall guarantee the installed cable accessories for a minimum period of not less than 5 years from the date of installation. The stores/materials found defective within the above guarantee period, shall be replaced by the supplier free of cost within one month of receipt of intimation.

If the defective stores/materials are not replaced as per the above guarantee clause, the Company shall recover an equivalent amount plus 15% supervision charges from any of the supplier's bills.

13.00 QUALITY CONTROL

The purchaser has a right to send team of experienced Engineers for assessing the capability of the firm for manufacturing and testing of Cable jointing kit as per this specification. The purchaser representative should be given all assistances and cooperation for inspection and testing at the bidder's work.

13.01 QUALITY ASSURANCE PLAN

The tendered shall invariably furnish QAP along with his offer, The QAP adopted by him in the process of manufacturing shall consist of

- a. List of Plant and Machinery available at the manufacturers premises.
- b. List of Testing equipment available at the manufacturers premises with their calibration schedule.
- c. Organizational chart.

14.00 PACKING:

The Cable jointing kits shall be suitably packed to avoid damage or disturbance during transit or handling. Each Cable jointing kits may be suitably packed in the first instance to prevent ingress of moisture and dust and then placed in a cushioned carton of a suitable material to prevent damage due to shocks during transit. The lid of the cartoon may be suitably sealed. A suitable number of sealed cartons may be packed in a case of adequate strength with extra cushioning if considered necessary. The cases may then be properly sealed against accidental opening in transit.

The following information shall be furnished with the consignment :

Name of consignee

Details of consignment

Destination

Total Weight of consignment.

Sign showing upper / lower side of the crate

Sign showing fragility of the material.

Handling and unpacking instructions.

Bill of Materials indicating contents of each component and spare materials.

Installation instructions including drawing or other information specific to the accessories.

15.00 TENDER SAMPLE

Tenderers are required to submit one number of cable joint/termination sample of each offered type/item as per Technical Specification of tender documents, from any one of the factories on before the time and date stipulated for submission of offer, for evaluations. The sample shall be clearly mark with each type / item for each sample submitted a name of bidder.

16.00 SCHEDULES

The tenderer shall fill in the following schedules which are part and parcel of the tender specification and offer. If the schedules are not submitted duly filled in with the offer, the offer shall be liable for rejection.

Schedule A – Guaranteed and technical particulars.

Schedule B – Tenderer's experience.

The discrepancies if any between the specification and the catalogs and / or literatures submitted as part of the offer by the bidders, the same shall not be considered and representations in this regard will not be entertained.

STRAIGHT THROUGH/TERMINATIONS/TRANSITION JOINTING KITS FOR HT LT ARMoured
PVC / XLPE ALUMINIUM /COPPER CONDUCTOR CABLES

SCHEDULE-A1
GTP FOR HT CABLE ACCESSORIES ie JOINTS & TERMINATIONS
(Heat Shrinkable)

Sr. No.	Particulars	MSEDCL Requirement	Bidder Offer.
1	Manufacturer' Name& Address		
2	Brand Name &Country of Origin		
3	Kit Storage Temperature	50°C max	
4	Voltage Grade(Kv)	12, 24 & 36	
5	Applicable Standards	Indicated in Cl.No.4 of Technical Spec.	
6	Material to be used	cross link Polymeric	
7	Type Of Kit Offered	1)Straight through Joint. 2)Transition joint. 3)Termination joint.	
8	Shelf life of components in the kit	Unlimited	
9	Time Required for energization after completion of termination/joint	Immediate.	
10	Conductor resistance test (As per cable cross section area)	Conductor resistance shall not vary more than 10% of initial value	
11	A.C. withstand voltage ph/ground) @ 4.5 U _o	4.5 U _o for 5 min #	
12	Heat Cycle in air 8 hours total with > 2hours steady heating and >3 hours cooling	30 Cycles at 2.5U _o #	
13	Heat Cycle in water 8 hours total with >2 hours steady heating and >3 hours cooling	30 Cycles at 2.5U _o #	
14	Partial discharge test @ 1.73 U _o 10 pC max at max temp as well as room Temperature	Max 10 pC #	
15	Humidity test (Only for Indoor termination)	300hours @ 1.25U _o #	
16	Salt fog test (Only for Outdoor termination)	1000hours @ 1.25U _o #	

**STRAIGHT THROUGH/TERMINATIONS/TRANSITION JOINTING KITS FOR HT LT ARMoured
PVC / XLPE ALUMINIUM /COPPER CONDUCTOR CABLES**

Sr.no	Particulars	MSEDCL requirement	Bidder offer
17	Dielectric Strength for 1)insulating Tube. 2)Anti tracking Tube 3)Dual wall tube	1)10(min) 2)10(min) 3)10(min)	
18	Dielectric constant for 1) stress control tube 2)insulating tube 3)anti tracking Tube 4)dual wall Tube 5) stress control mastic	1)15(min) 2)3.5(min) 3)3.5(min) 4) 3.5(min) 5)9.0(min)	
19	Tensile strength for 1)stress control tube 2)insulating tube 3)anti tracking tube 4)dual wall tube 5) stress control mastic	1)10 N/sq.mm(min) 2) 10 N/sq.mm(min) 3) 8 N/ sq.mm(min) 4) 10 N/sq.mm(min) 5) 8 N/sq.mm (min)	
20	Ultimate Elongation for 1)stress control tube 2)insulating tube 3)anti tracking tube 4)dual wall tube 5) stress control mastic	1)200% 2)200% 3)200% 4)200% 5)200%	
21	Water Absorption for 1)Stress Control Tube 2)Insulating Tube 3)Anti Tracking Tube 4)Dual wall Tube 5) Stress control mastic	1)0.5% 2) 0.5% 3) 0.5% 4) 0.5% 5)0.5%	
22	Longitudinal Change for 1)stress control tube/ 2)insulating tube 3)anti tracking tube 4)dual wall tube	1) max 10% 2) max 10% 3) max 10% 4) max 10%	
23	Heat Shock for 1) stress control Tube 2)insulating tube 3)anti tracking tube 4)dual wall tube	1)30min@250 ^o c, 2)30min@250 ^o c, 3)30min@250 ^o c, 4)30min@250 ^o c	
24	Flammability for insulating tube/anti tracking tube/dual wall tube	Pass	
25	Tracking Resistance for anti tracking tube	Non tracking	
26	Dissipation factor for stress control mastic	0.15(max)	

**STRAIGHT THROUGH/TERMINATIONS/TRANSITION JOINTING KITS FOR HT LT ARMoured
PVC / XLPE ALUMINIUM /COPPER CONDUCTOR CABLES**

S No	Particulars	MSEDCL Requirement	Bidder Offer
27	Service Temperature for stress control mastic	90° C	
28	Heat shrink wraparound sleeves with SS Channels	As per specification (clause no.5.01)	
29	Canister/GI Wire Mesh	As per cable size	
30	Red mastic	As per cable size	
31	G.I. Solid Collet	As per cable size	
32	Copper Braid	As per requirement	
33	Co-extruded Heat shrink Dual wall tube	As per specification (clause no.5.01)	
34	Heat shrink insulating tube	As per specification (clause no.5.01)	
35	Heat shrink stress control tube	As per specification (clause no.5.01)	
36	Stress Grading mastic	As per specification (clause no.5.01)	
37	Ferrule/Connector	As per specification (clause no.5.01& 5.02)	
38	PVC NA Tape	As per requirement	
39	PVC Adhesive Tape	As per requirement	
40	Cleaning Liquid	As per requirement	
41	Aluminum Oxide cloth	As per requirement	
42	Heat shrink break boot(Termination)	As per specification (clause no.5.02)	
43	Heat stress control tube	As per specification (clause no.5.02)	
44	Heat shrink Anti tracking tube	As per specification (clause no.5.02)	
45	Rain sheds (Termination)	As per specification (clause no.5.02)	
46	List Of Contents Of Kit (To Be Furnished Separately)	Detailed component list with Quantity etc.	

These values are indicated in IS-13575 part –I at clause no.6.1,7.2.

IS-13573 part-II at clause no.4.4.2,4.5.2&5.1,

IS-13573 part-III at clause no.4.1 (in accordance with IS -10810) 7.1,9&13

**STRAIGHT THROUGH/TERMINATIONS/TRANSITION JOINTING KITS FOR HT LT ARMoured
PVC / XLPE ALUMINIUM /COPPER CONDUCTOR CABLES**

**SCHEDULE-A2
GTP FOR HT CABLE ACCESSORIES ie JOINTS & TERMINATIONS
(Cold Shrinkable)**

Sr. No.	Particulars	MSEDCL Requirement	Bidder Offer.
1	Manufacturer' Name & Address		
2	Brand Name & Country of Origin		
3	Kit Storage Temperature	50° C max	
4	Voltage Grade	12kv, 24kv & 36kv	
5	Applicable Standards	Indicated in Cl.No.4 of Technical Spec.	
6	Material to be used	Polyurethane Polymeric	
7	Type of Kit offered	1) Straight through Joint. 2) Transition joint. 3) Termination joint.	
8	Shelf life of components in the kit except compound	Unlimited	
9	Time required for energisation after completion of termination/joint.	Immediate.	
10	Conductor resistance test (As per cable cross section area)	Conductor resistance shall not vary more than 10% of initial value. #	
11	A.C. withstand voltage ph/ground) @ 4.5 U _o	4.5 U _o for 5 min #	
12	Heat Cycle in air 8 hours total with > 2 hours steady heating and > 3 hours cooling	30 Cycles at 2.5U _o #	
13	Heat Cycle in water 8 hours total with > 2 hours steady heating and > 3 hours cooling	30 Cycles at 2.5U _o #	
14	Partial discharge test @ 1.73 U _o 10 pC max at max temp as well as room temperature	Max 10 pC #	
15	Humidity test (only for indoor termination)	300 hours @ 1.25U _o #	
16	Ultra violet test	No cracking #	
17	Dielectric Strength for 1) stress control tube 2) insulating material (body insulation)	1) 8 kv/mm, 2) 20 kv/mm	
18	Dielectric constant for 1) stress control tube 2) insulating material (body insulation), 3) Silicon rubber	1) 18, 2) 3.5 3) 3.5	
19	Volume Resistivity for 1) stress control tube 2) insulating material (body insulation)	1) 1x10 ² ohm.cm, 2) 1x10 ¹⁵ ohm.cm,	

**STRAIGHT THROUGH/TERMINATIONS/TRANSITION JOINTING KITS FOR HT LT ARMoured
PVC / XLPE ALUMINIUM /COPPER CONDUCTOR CABLES**

S N	Particulars	MSEDCL Requirement	Bidder Offer
20	Ultimate Elongation for 1)stress control tube 2) insulating material(body insulation)	1)700%, 2)700%,	
21	Hardness for 1) stress control tube 2)insulating material(body insulation)	1)35±5 shoreA, 2)40±5 shoreA	
22	Dielectric loss factor tan delta for 1)stress control tube/ 2)insulating material(body insulation), 3)silicon rubber	1)0.08, 2)0.005 3)0.004	
23	Service temperature range		
	1)stress control tube 2) insulating material(body insulation)	1) -50 up to 130°C 2)-50 up to 130°C	
24	Installation temperature range for 1)stress control tube 2) insulating material(body insulation)	-20 up to 50°C	
25	Tear Resistance for insulating material(body insulation)	26 N/mm	
26	Silicon rubber (Permanent set 22hours 100°C 100% elongation 5min)	8%	
27	Tracking Resistance for Silicon rubber	10 Hrs Non tracking	
28	Armour cast material	As per specification (clause no.5.03)	
29	Mastic Tape 2229i	As per requirement	
30	Mastic	As per requirement	
31	Worn drive clip	As per cable size	
32	G.I. solid collect	As per cable size	
33	Copper braid	As per requirement	
34	Cold shrink splice body	As per specification (clause no 5.03)	
35	Ferrule/mechanical connector	As per specification (clause no 5.03&5.04)	
36	Semiconducting tape	As per requirement	
37	Pvc NA tape	As per requirement	
38	Pvc adhesive tape	As per requirement	
39	Aluminum Oxide cloth	As per requirement	
40	Pvc cleaning liquid	As per requirement	
41	Trifercating break out boot(Termination)	As per specification(clause no 5.03)	
42	Mono plast tape/pvc tape	As per cable size requirement	
43	Silicone tape	As per cable size requirement	
44	Cold shrink termination Body with stress control material	As per specification(clause no 5.03)	

STRAIGHT THROUGH/TERMINATIONS/TRANSITION JOINTING KITS FOR HT LT ARMoured
PVC / XLPE ALUMINIUM /COPPER CONDUCTOR CABLES

SN	Particulars	MSEDCL Requirement	Bidder Offer
45	Rain sheds(Termination)	As per requirement	
46	List Of Contents Of Kit (To Be Furnished Separately)	Detailed component list with Quantity etc.	

These values are indicated in IS-13575 part –I at clause no.6.1,7.2.

IS-13573 part-II at clause no.4.4.2,4.5.2&5.1,

IS-13573 part-III at clause no.4.1 (in accordance with IS -10810) 7.1,9&13

SCHEDULE-A3
GTP FOR LT CABLE ACCESSORIES ie JOINTS & TERMINATIONS
(Heat Shrinkable)

Sr. No.	Particulars	MSEDCL Requirement	Bidder Offer.
1	Manufacturer' Name& Address		
2	Brand Name &Country of Origin		
3	Kit Storage Temperature	50°C max	
4	Voltage Grade	1.1kv	
5	Applicable Standards	Indicated in Cl.No.4 of Technical Spec.	
6	Material to be used	Polymeric Heat shrinkable material	
7	Type Of Kit Offered	1)Straight through Joint. 2)Transition joint. 3)Termination joint.	
8	Shelf life of components in the kit	Unlimited.	
9	Time Required for energisation after completion of termination/joint.	Immediate.	
10	Impulse withstand on Low voltage kits.	As per IS 13573 joints classification.for cable size less than50sqmm.it will be 8kv & for cable size more than 50sqmm.it will be 20kv	
11	Heating cycle in Air	As per IS-13573 part-I See 8.3	
12	Heat Cycle in Water(Over sheath damage)	As per IS-13573 part-I See 8.3	
13	Insulation resistance(Immersed)	As per IS-13573 part-I See 8.4	
14	Insulation resistance(Air)	As per IS-13573 part-I See 8.4	

**STRAIGHT THROUGH/TERMINATIONS/TRANSITION JOINTING KITS FOR HT LT ARMoured
PVC / XLPE ALUMINIUM /COPPER CONDUCTOR CABLES**

Sr.No.	Particulars	MSEDCL requirement	Bidder offer
15	Impact at ambient temp.	As per IS-13573 part-I See 8.5	
16	AC High voltage withstand(in Air)	As per IS-13573 part-I See 8.6	
17	AC High voltage withstand(immersed)	As per IS-13573 part-I See 8.6	
18	Examination of joint.	As per IS-13573 part-I See 8.8	
19	Dielectric Strength for insulating Tube.	9kv/mm	
20	Dielectric constant for insulating tube	3.5(min)	
21	Tensile strength for insulating tube	12.5 N/mm ²	
22	Ultimate Elongation for insulating tube	200%	
23	Water Absorption for Insulating Tube	0.3%	
24	Longitudinal Change for insulating tube	±10%	
25	Heat Shock for insulating tube	30min@250 ^o c,	
26	Flammability for insulating tube	Pass	
27	Heat Shrinkable Wraparound sleeves with SS Channels	As per specification (clause no.5.01& 5.02)	
28	G.I. Wire mesh / Canister	As per cable size	
29	Red mastic	As per cable size	
30	G.I. Solid Collet	As per cable size	
31	Earthing Conductor	As per requirement	
32	Ferrule	As per specification (clause no.5.01&5.02)	
33	PVC NA Tape	As per requirement	
34	PVC Adhesive Tape	As per requirement	
35	Cleaning Liquid	As per requirement	
36	Aluminum Oxide cloth	As per requirement	
37	Heat shrink break boot(Termination)	As per specification (clause no.5.02)	
38	List Of Contents Of Kit (To Be Furnished Separately)	Detailed component list with Quantity etc.	

STRAIGHT THROUGH/TERMINATIONS/TRANSITION JOINTING KITS FOR HT LT ARMoured
PVC / XLPE ALUMINIUM /COPPER CONDUCTOR CABLES

SCHEDULE-A4
GTP FOR LT CABLE ACCESSORIES ie JOINTS & TERMINATIONS
(Cold Shrinkable/Mechanical types)

Sr. No.	Particulars	MSEDCL Requirement	Bidder Offer.
1	Manufacturer' Name& Address		
2	Brand Name &Country of Origin		
3	Kit Storage Temperature	50°C max	
4	Voltage Grade	1.1kv	
5	Applicable Standards	Indicated in Cl.No.4 of Technical Spec.	
6	Material to be used	Rubber tubes for Cold shrink tubes..	
7	Type Of Kit Offered	1)Straight through Joint. 2)Termination joint.	
8	Shelf life of components in the kit	Unlimited.	
9	Time Required for energisation after completion of termination/joint.	Immediate.	
10	Impulse withstand on Low voltage kits.	As per IS 13573 joints classification.for cable size less than50sqmm.it will be 8kv & for cable size more than 50sqmm.it will be 20kv	
11	Heating cycle in Air	As per IS-13573 part-I See 8.3	
12	Heat Cycle in Water(Over sheath damage)	As per IS-13573 part-I See 8.3	
13	Insulation resistance(Immersed)	As per IS-13573 part-I See 8.4	
14	Insulation resistance(Air)	As per IS-13573 part-I See 8.4	
15	Impact at ambient temp.	As per IS-13573 part-I See 8.5	
16	AC High voltage withstand(In Air)	As per IS-13573 part-I See 8.6	

STRAIGHT THROUGH/TERMINATIONS/TRANSITION JOINTING KITS FOR HT LT ARMoured
PVC / XLPE ALUMINIUM /COPPER CONDUCTOR CABLES

SN	Particulars	MSEDCL Requirement	Bidder Offer
17	AC High voltage withstand(immersed)	As per IS-13573 part-I See 8.6	
18	Examination of joint.	As per IS-13573 part-I See 8.8	
19	Dielectric Strength for insulating Tube.	20 kv/mm	
20	Dielectric constant for insulating tube	3.5(min)	
21	Tensile strength for insulating tube	8N/mm ²	
22	Ultimate Elongation for insulating tube	700 %	
23	Water Absorption for Insulating Tube	0.5%	
24	Longitudinal Change for insulating tube	±10%	
25	Mastic2229i+ Vinyl tape and Armour cast for encapsulation.	To be used after completion of joint for encapsulation.	
26	G.I. Solid Collet	As per cable size	
27	Earthing Conductor	As per requirement	
28	Ferrule/Connector	As per specification (clause no.5.03&5.05)	
29	No. of shearing type bolts/special studs provided on connectorbarrel.	4 to 6 nos. to have secured connection.	
30	Material for armour connectivity.	Suitable tinned copper braiding required.	
31	Insulating tubing over the connector.	Dual wall design sleeve with entrapped lubricant with sufficient length to cover connector.	
32	Mechanical protection to joint body.	Suitable armour wrapping required.	
33	PVC NA Tape	As per requirement	
34	PVC Adhesive Tape	As per requirement	
35	Cleaning Liquid	As per requirement	
36	Aluminum Oxide cloth	As per requirement	
37	Side on Break out/Molds with compound.	As per specification (clause no.5.02)	
38	List Of Contents Of Kit (To Be Furnished Separately)	Detailed component list with Quantity etc.	

SCHEDULE - "B"

TENDERER'S EXPERIENCE

Tenderer shall furnish here list of similar orders executed / under execution for supplying HT/LT Cable Accessories by him to whom a reference may be made by purchaser in case he considers such a reference necessary.

Sr. No.	Name of client	Order No. & date	Qty. ordered	Qty. supplied
------------	----------------	------------------	--------------	------------------

**STRAIGHT THROUGH JOINTS/TERMINATIONS /TRANSITION JOINTS
FOR HT / LT ARMoured PVC / XLPE, ALUMINIUM /COPPER
CONDUCTOR CABLES**

“INDEMNITY BOND FORMAT”

UNDERTAKING TO BE SUBMITTED BY THE PARENT COMPANY SITUATED ABROAD IN
CASE OF THE PARTICIPANT BIDDER WHO IS AN INDIAN
BASED SUBSIDIARY ON GENERAL STAMP OF Rs. 200.00.

The Chief Engineer,
Maharashtra State Electricity Distribution Co. Ltd.,
Material Management Cell,
1st Floor, Prakashgad, Bandra (E),
Mumbai – 400 056

Dear Sir:

Sub: Undertaking against Tender No _____ for procurement of _____

We, M/s. _____ having registered office at _____ are the Parent Company of M/s. _____ who have participated against your tender no. _____ for procurement of _____.

We have carefully read and have thoroughly understood and agree to the terms and conditions of the subject tender.

We hereby undertake that in case of placement of order against the subject tender on our subsidiary company, M/s. _____, in the event of we accept all the responsibilities and liabilities for supply of quality equipments as per specification of the tender and execution of the contract. We further hereby undertake that we shall be responsible for any liability arising out of the contract placed on M/s _____ and pay to MSEDCL the sum of rupees _____ as per agreement in the event of any breach of condition of the purchase order, loss and damage of the material till expiry of guarantee period as stipulated in the order.

Our liability here under shall not be impaired or discharged by extension of time or variation or alteration made with or without our knowledge or consent by or between the parties to the said contract. This undertaking shall be valid and binding on us upto and including the execution and guarantee period of the order and shall not be terminable by notice or change in the constitution of any of the companies. In case of any dispute arising out of or in connection with this tender or contract, if concluded, the same shall be subject to the exclusive jurisdiction of the **“Court in Mumbai(India).”**

Yours faithfully,
(Authorised Signatory)

For _____

STRAIGHT THROUGH JOINTS/TERMINATIONS /TRANSITION JOINTS FOR HT / LT ARMoured PVC / XLPE, ALUMINIUM /COPPER CONDUCTOR CABLES

Maharashtra State Electricity Distribution Company Limited
MSEDCL11KVIDT - Indicative

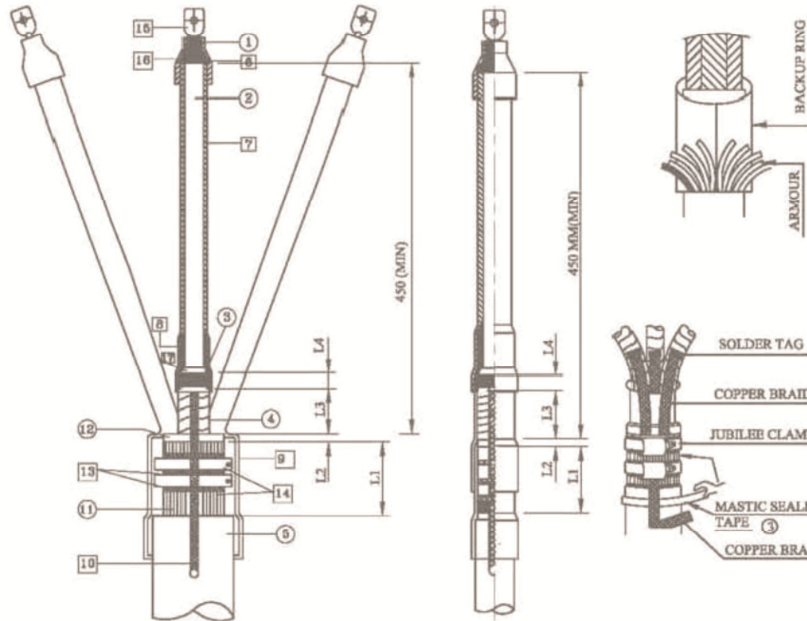

3 Core XLPE Cable

1 Core XLPE / AB Cable

Ref. Document No. :- 103

CABLE SIZE (Sq.mm)	CABLE CUTTING DIMENSIONS FOR 3 CORE CABLES				CABLE SIZE (Sq.mm)	CABLE CUTTING DIMENSIONS FOR 1 CORE CABLES			
	L1	L2	L3	L4		L1	L2	L3	L4
240-400	65	10	150	30	800-1000	65	10	150	30
150-185	50	10	150	30	400-630	65	10	150	30
70-120	40	10	150	30	185-300	65	10	150	30
16-50	40	10	150	30	70-150	40	10	150	30
					16-50	40	10	150	30

○	CABLE COMPONENTS
□	KIT CONTENTS (MAJOR PARTS)
△	KIT CONTENTS (INSTALLATION AIDS)
L4	LENGTH OF SEMI CONDUCTING SCREEN OF CORE
L3	LENGTH OF METALLIC SHIELDING OF CORE
L2	LENGTH OF INNER SHEATH
L1	LENGTH OF ARMOUR
LEGENDS	

▲	MOPPING CLOTH
▲	ALOXITE EMERY TAPE
▲	NYLON STRING
▲	SILICON GREASE
17	STRESS CONTROL MASTIC
18	LUG SEALING MASTIC RED
15	TERMINAL LUG
14	MASTIC SEALING TAPE
13	JUBILEE CLAMPS
12	INNER SHEATH
11	ARMOUR
10	TINNED COPPER EARTH BRAID (MAIN EARTH)
9	ANTI TRACKING CABLE BREAK OUT
8	STRESS CONTROL TUBING
7	ANTI TRACKING WEATHER RESISTANT TUBING
6	TERMINAL SLEEVE
5	OUTER SHEATH
4	METAL SHIELD
3	SEMI CONDUCTING SCREEN
2	INSULATION
1	CONDUCTOR
S.No	DESCRIPTION



Title :-
Heat Shrinkable Indoor Termination
for 6.6/11.0KV, 6.35/11.0KV (U max:
12KV) 3&1 Core XLPE & AB Cable

SCALE : NTS
ESTION No. : 00
ENGL No. : MSEDCL11KVIDT

Drawn By: MSEDCL Technical Ckd. BY: APPD. BY: DATE: 10/05/17

STRAIGHT THROUGH JOINTS/TERMINATIONS /TRANSITION JOINTS FOR HT / LT ARMOURED PVC / XLPE, ALUMINIUM /COPPER CONDUCTOR CABLES

Maharashtra State Electricity Distribution Company Limited
MSEDCL11KVODT - Indicative

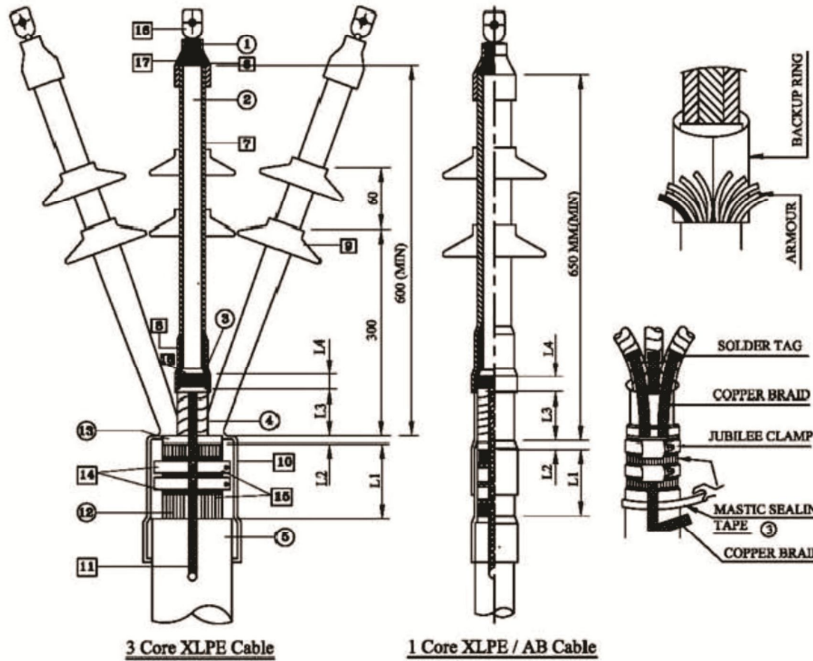

CABLE CUTTING DIMENSIONS FOR 3 CORE CABLES					CABLE CUTTING DIMENSIONS FOR 1 CORE CABLES				
CABLE SIZE (Sq.mm)	L1	L2	L3	L4	CABLE SIZE (Sq.mm)	L1	L2	L3	L4
240-400	65	10	150	30	800-1000	65	10	150	30
150-185	50	10	150	30	400-630	65	10	150	30
70-120	40	10	150	30	185-300	65	10	150	30
16-50	40	10	150	30	70-150	40	10	150	30
					16-50	40	10	150	30

○	CABLE COMPONENTS
□	KIT CONTENTS (MAJOR PARTS)
△	KIT CONTENTS (INSTALLATION AIDS)
L4	LENGTH OF SEMI CONDUCTING SCREEN OF CORE
L3	LENGTH OF METALLIC SHIELDING OF CORE
L2	LENGTH OF INNER SHEATH
L1	LENGTH OF ARMOUR
LEGENDS	

▲	MOPPING CLOTH
▲	ALOXITE EMERY TAPE
▲	NYLON STRING
▲	SILICON GREASE
16	STRESS CONTROL MASTIC
17	LUG SEALING MASTIC RED
18	TERMINAL LUG
15	MASTIC SEALING TAPE
4	JUBILEE CLAMPS
3	INNER SHEATH
2	ARMOUR
11	TINNED COPPER EARTH BRAID (MAIN EARTH)
10	ANTI TRACKING CABLE BREAK OUT
9	RAIN SHED
8	STRESS CONTRL TUBING
7	ANTI TRACKING WEATHER RESISTANT TUBING
6	TERMINAL SLEEVE
5	OUTER SHEATH
4	METAL SHIELD
3	SEMI CONDUCTN SCREEN
2	INSULATION
1	CONDUCTOR

S.No.	DESCRIPTION
-------	-------------



Title :- Heat Shrinkable Outdoor Termination For 6.6/8.8KV, 6.35/11.0KV(U max: 12 KV) 3&1 Core XLPE & AB Cables		 SCALE : NTS EMITION No. : 00
Drawn By: MSEDCL Technical	CHKD. BY: APPD. BY: DATE: 10/05/17	

STRAIGHT THROUGH JOINTS/TERMINATIONS /TRANSITION JOINTS FOR HT / LT ARMoured PVC / XLPE, ALUMINIUM /COPPER CONDUCTOR CABLES

Maharashtra State Electricity Distribution Company Limited
MSEDCL11KVSTJ - Indicative

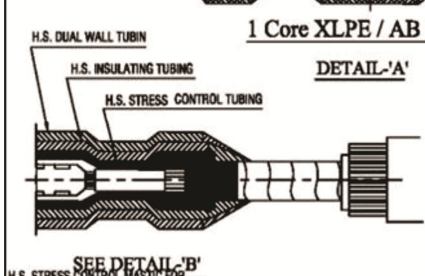
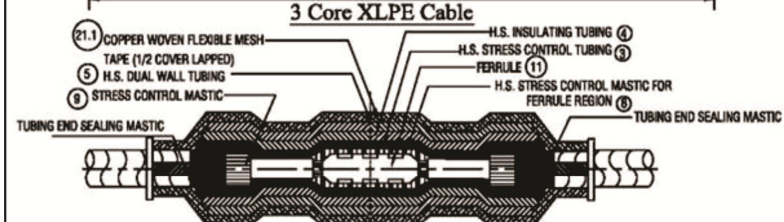
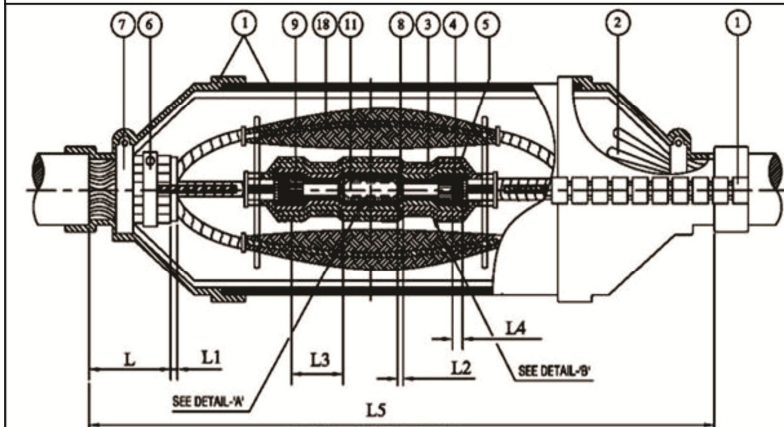

L4	LENGTH OF SEMI CONDUCTING SCREEN
L3	LENGTH OF XLPE INSULATION
L2	LENGTH OF BARE CONDUCTOR BETWEEN FERRULE AND XLPE INSULATION
L1	LENGTH OF INNER SHEATH
L	LENGTH OF ARMOUR
LEGEND	

400-500	80	10	10	75	60	1475
240-300	80	10	10	75	60	1425
120-185	80	10	10	75	60	1300
70-95	80	10	10	75	60	1250
16-50	80	10	10	75	60	1250
Cable size sq. mm	L	L1	L2	L3	L4	L5
Cable Cutting Dimensions for 3 Core XLPE Cables						
800-1000	60	10	10	75	55	1220
400-630	60	10	10	75	55	1200
150-300	60	10	10	75	55	1100
70-120	60	10	10	75	55	1050
25-50	60	10	10	75	55	1000
Cable size sq. mm	L	L1	L2	L3	L4	L5
Cable Cutting Dimensions for 1 Core XLPE Cables						

19	DETAILED INSTRUCTION MANUAL
18	METAL SCREEN CONTINUITY SYSTEM CONSISTING OF COPPER WOVEN FLEXIBLE MESH TAPE + SMALL COPPER BRAID+ SOLDER + FLUX+COPPER BENDING WIRE
17	CLEANING TISSUES
16	MOPPING CLOTH
15	PVC ADHESIVE TAPE
14	ALOXIDE EMERY TAPE
13	NYLON STRING
12	MASTIC SEALING TAPES
11	INLINE CONNECTORS (FERRULE)
10	SILICON GREASE
9	STRESS CONTROL MASTIC FOR CUT END
8	STRESS CONTROL MASTIC FOR FERRULE REGION
7	JUBILEE CLAMPS FOR FIXING OVER THE PROTECTIVE COVER (CANNISTER)
6	ARMOUR EARTHING MATERIAL (BACKUP RING -2 NOS.+ TINNED COPPER BRAID + JUBILEE CLAMP - 2 NOS.)
5	HEAT SHRINKABLE DUAL WALL TUBINGS (RED + BLACK)
4	HEAT SHRINKABLE INSULATION TUBINGS (RED)
3	HEAT SHRINKABLE STRESS CONTROL TUBINGS (BLACK)
2	GALVANISED WRAP AROUND JOINT CASE (CANNISTER)
1	HEAT SHRINKABLE OUTER JACKETING SLEEVE
S.No.	DESCRIPTION OF KIT CONTENTS

MAHAVITARAN
Maharashtra State Electricity Distribution Co. Ltd.

TITLE :- HEAT SHRINKABLE STRAIGHT THROUGH JOINT SUITABLE FOR 6.6/8.8KV, 6.35/11.0KV (U max: 12KV) 3 & 1 CORE XLPE & AB CABLES				
Drawn. By MSEDCL Technical	CRD. BY	APPO. BY	DATE 08/13/18	
SCALE : NTS				ESTION No. : 00 ORG. No. MSEDCL11KVSTJ
DATE				

STRAIGHT THROUGH JOINTS/TERMINATIONS /TRANSITION JOINTS FOR HT / LT ARMOURED PVC / XLPE, ALUMINIUM /COPPER CONDUCTOR CABLES

Maharashtra State Electricity Distribution Company Limited
MSEDCL11KVODT - Indicative

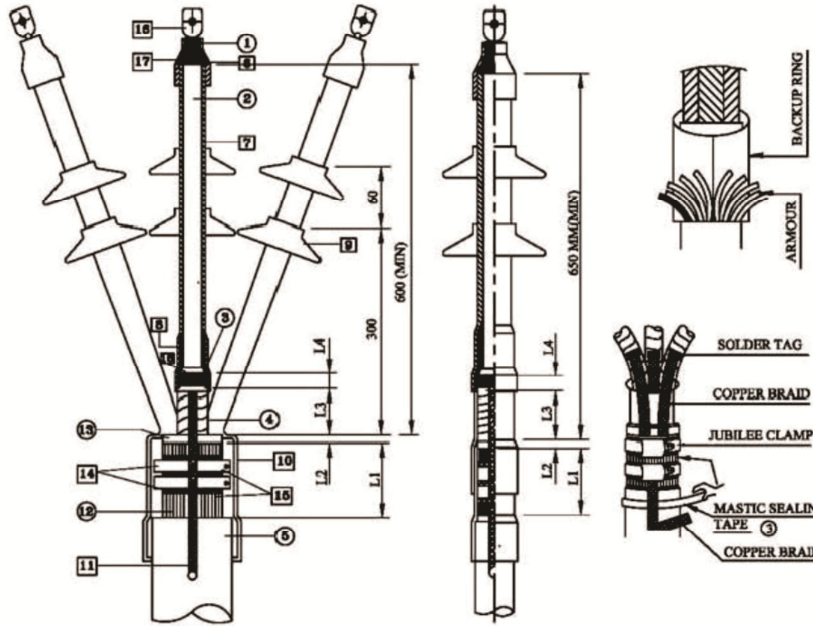

3 Core XLPE Cable

1 Core XLPE / AB Cable

CABLE SIZE (Sq.mm)	CABLE CUTTING DIMENSIONS FOR 3 CORE CABLES				CABLE CUTTING DIMENSIONS FOR 1 CORE CABLES				
	L1	L2	L3	L4	CABLE SIZE (Sq.mm)	L1	L2	L3	L4
240-400	65	10	150	30	800-1000	65	10	150	30
150-185	50	10	150	30	400-630	65	10	150	30
70-120	40	10	150	30	185-300	65	10	150	30
16-50	40	10	150	30	70-150	40	10	150	30
					16-50	40	10	150	30

○	CABLE COMPONENTS
□	KIT CONTENTS (MAJOR PARTS)
△	KIT CONTENTS (INSTALLATION AIDS)
L4	LENGTH OF SEMI CONDUCTING SCREEN OF CORE
L3	LENGTH OF METALLIC SHIELDING OF CORE
L2	LENGTH OF INNER SHEATH
L1	LENGTH OF ARMOUR
LEGENDS	

▲	MOPPING CLOTH
▲	ALOXITE EMERY TAPE
▲	NYLON STRING
▲	SILICON GREASE
16	STRESS CONTROL MASTIC
17	LUG SEALING MASTIC RED
18	TERMINAL LUG
15	MASTIC SEALING TAPE
14	JUBILEE CLAMPS
13	INNER SHEATH
12	ARMOUR
11	TINNED COPPER EARTH BRAID (MAIN EARTH)
10	ANTI TRACKING CABLE BREAK OUT
9	RAIN SHED
8	STRESS CONTRL TUBING
7	ANTI TRACKING WEATHER RESISTANT TUBING
6	TERMINAL SLEEVE
6	OUTER SHEATH
4	METAL SHIELD
3	SEMI CONDUCTN SCREEN
2	INSULATION
1	CONDUCTOR

S.No.	DESCRIPTION
-------	-------------



MAHAVITARAN
Maharashtra State Electricity Distribution Co. Ltd.

Title :-
Heat Shrinkable Outdoor Termination
For 6.6/8.8KV, 6.35/11.0KV(U max: 12 KV)
3&1 Core XLPE & AB Cables

Drawn By: MSEDCL Technical	CHK. BY:	APPD. BY:	DATE: 10/05/17	SCALE : NTS	EMITION No. : 00
-------------------------------	----------	-----------	-------------------	-------------	------------------

DRG. No.
MSEDCL11KVODT