

**TECHNICAL SPECIFICATION OF 100 kVA to 2500 kVA , 11/0.433 kV & 22/0.433 kV
DRY-TYPE (VPI) DISTRIBUTION TRANSFORMERS (Indoor and Outdoor).**

MATERIAL SPECIFICATIONS CELL

TECHNICAL SPECIFICATION

OF

**100 KVA ,200kVA, 315kVA, 630 kVA, 1000 KVA ,1250 KVA , 1600
kVA,2000 KVA and 2500 KVA , 11/0.433 kV & 22/0.433 kV
DRY-TYPE (VPI) DISTRIBUTION TRANSFORMERS
(Indoor and Outdoor)**

**TECHNICAL SPECIFICATION OF 100 kVA to 2500 kVA , 11/0.433 kV & 22/0.433 kV
DRY-TYPE (VPI) DISTRIBUTION TRANSFORMERS (Indoor and Outdoor).**

I N D E X

Clause No.	Contents
1	Scope
2	System Particulars
3	Service Condition
4	Applicable Standards
5	Specific Technical requirement
6	Design & Construction
6.1	Core
6.5	Tie Bolt
6.6	Windings
6.8	Losses
6.9	Clearances
6.10	Transformer Enclosure
7	H. T. & L. T. Bushing
8	H.T./L.T. Cable Box
9	Terminal
10	Terminal Marking Plate & Rating Plate
11	Fittings
12	Test and inspection
13	Type Tests
14	Drawings
15	Rejection
16	Cleaning and Painting
17	Guaranteed Technical Particulars for Transformers
18	Testing facilities
19	Submission Routine Test Certificate
20	Stage Inspection
21	Testing of all Distribution Transformers for no load and full load losses
22	Random Sample Testing (RST)
23	Quality Assurance
24	Qualifying Requirement
25	Final inspection
26	Performance Guarantee
27	Schedule
Schedule A	Guaranteed Technical Particulars
Annexure-I	Unbalanced Current Test
Annexure -II	Temperature Rise Test

TECHNICAL SPECIFICATION OF 100 kVA to 2500 kVA , 11/0.433 kV & 22/0.433 kV DRY-TYPE (VPI) DISTRIBUTION TRANSFORMERS (Indoor and Outdoor).

1 **Scope:**

- 1.1 The specification covers design manufacture, testing packing and delivery of 3 phase 50 Hz, Dry Type (VPI) distribution transformer of ratings 100, 200,315,630,1000,1250 , 1600 And 2500 kVA, 11/0.433 kV &22/0.433 KV (Indoor and Outdoor type) natural air cooled (ANAN) , conforming IS: 2026 Part (I TO IV), IS: 11171 1985 and IEC726/1982.
- 1.2 The equipment offered shall be complete with all necessary parts for effective and trouble-free operation in the distribution system. Such parts will be deemed to be within the scope of the supply irrespective of whether they are specifically indicated in the commercial order or not.
- 1.3 It is not the intent to specify herein complete details of design and construction. The equipment offered shall conform to all relevant standards and be of high quality, sturdy, robust and of good workmanship and complete design in all respects. The equipment shall be capable to perform continuous and satisfactory operations in the actual service conditions at site and shall have sufficiently long life in service as per statutory requirements.
- 1.4 The manufactures attention is drawn to clause no. 3.2.3 of IS – 11171/1985 in respect to the restricted cooling/air circulations available and poor ventilation inside vaults/basement and enclosed rooms where the transformers are required to be installed. The maximum surrounding temperature at these locations is about 55 degC.
- 1.5 The insulating materials shall be suitably processed such that in effect they act as fire retardant.
- 1.6 The Tenderer /supplier shall bind himself to abide by these considerations to the entire satisfaction of the purchaser and will be required to adjust such details at no extra cost to the purchaser over and above the tendered rates and prices.

1.7 **Tolerances:**

Tolerances on all the dimensions shall be in accordance with provisions made in the relevant IEC/Indian standards and in these specifications. Otherwise the same will be governed by good engineering practice in conformity with required quality of the product.]

2 **System Particulars:-**

- 2.1 The transformers shall be suitable for outdoor/indoor installation with following system particulars and should be suitable for service under fluctuations in supply voltage as permissible under Indian Electricity Act & Rules thereunder.
- 2.2 NominalSystemVoltage : 11kV or 22kV

**TECHNICAL SPECIFICATION OF 100 kVA to 2500 kVA , 11/0.433 kV & 22/0.433 kV
DRY-TYPE (VPI) DISTRIBUTION TRANSFORMERS (Indoor and Outdoor).**

- 2.3 Corresponding Highest System Voltage : 12kV or 24kV
2.4 Neutrale arthing : Solidly earthed
2.5 Frequency : 50 Hz with $\pm 3\%$ Tolerance

3 SERVICE CONDITIONS:

3.1 Equipment to be supplied against the specification shall be suitably design to work satisfactorily under following tropical conditions:-

- i Max. ambient air temperature : 50 Deg. C
- ii Max. relative humidity : 100 %
- iii Max. annual rain fall : 1450 mm
- iv Max. wind pressure : 150 kg/sq.m.
- v Max. altitude above mean sea level: 1000 mtrs.
- Vi Isoceraunic level 50
- vii Seismic level (Horizontal acceleration) : 0.3 g.
- viii Climatic Condition Moderately hot and humid tropical climate conducive to rust and fungus growth.
- ix Reference Ambient Temperature for temperature rise 50 degC

3.2 The climatic conditions are prone to wide variations in ambient conditions and hence the equipment shall be of suitably designed to work satisfactorily under the all conditions.

4. Applicable Standards:-

- i The design, manufacture and performance of the equipment shall comply with all currently applicable statutes, regulations and safety odes.
Nothing in this specification shall be construed to relieve the tenderer off his responsibilities.
- ii The transformers shall conform to IS: 2026& IS:11171/1985 amended upto date as amended up to date or other International Standards for equal or better performance.
- iii Unless otherwise specified, the equipment offered shall conform to the latest applicable Indian, IEC, British or U.S.A. Standards and in particular, to the following:-

**TECHNICAL SPECIFICATION OF 100 kVA to 2500 kVA , 11/0.433 kV & 22/0.433 kV
DRY-TYPE (VPI) DISTRIBUTION TRANSFORMERS (Indoor and Outdoor).**

a.	IS 2026 amended upto date	Specification for power Transformer
b.	IS:11171/1985 amended upto date	Specifications for Dry-type power transformers
c.	IS:2099 amended upto date	Specification for Bushings for Alternating Voltages above 1000 Volts
d.	IS:3347 amended upto date (part I to V)	Porcelain transformer bushings for use in normal and lightly polluted atmospheres
e.	IS 5	Colours for ready mixed paints and enamels.

- iv Unless otherwise modified in this specification the Distribution Transformers shall comply with the Indian Standard Specification IS: 2026 amended up to date.

In case of conflict arising out due to variations between the applicable standard and the standards specified herein the provisions of this specification should prevail.

5 Specific Technical requirement:

5.1 Standard kVA Ratings:-

5.1.1 The standard ratings of transformers shall be 100,200, 315, 630, 1000,1250,1600,2000 & 2500.

5.2 Nominal voltage ratings

i Primary voltage - 11 kV & 22

kV ii Secondary voltage- 0.433 kV

5.3 The windings of the transformers shall be connected to Delta (Δ) on the primary side and star (Y) on the secondary side. The neutral of the LT winding shall be brought out to a separate terminal. The vector group shall be Dyn-11.

5.4 For all above rating and voltage class transformers the percentage impedance at 75 deg C should be 5 % (subject to IS tolerance).up to 1000 kva and above it should be 6.25 % (Subject to IS tolerance)

5.5 Temperature Rise:

i. Average winding temperature rise over an ambient temperature of 50 deg. C shall not exceed 65deg.C measured by resistance method. i.e. Max. Temperature of the winding shall not exceeds 95° C.

ii Core, metallic parts and adjacent material shall in no case reach a

TECHNICAL SPECIFICATION OF 100 kVA to 2500 kVA , 11/0.433 kV & 22/0.433 kV DRY-TYPE (VPI) DISTRIBUTION TRANSFORMERS (Indoor and Outdoor).

value that may damage these material or reduce their life expectancies.

6 Design & construction

6.1 Core

- i. The core shall be of high grade cold rolled grain oriented (C.R.G.O) annealed steel lamination, having low loss and good grain properties, coated with insulation, bolted together to the frames firmly to prevent vibration or noise. All core clamping bolts shall be effectively insulated. The complete design of core must ensure permanency of the core losses with continuous working of the transformers.
- ii Core insulation –C-Class grade insulation paper of thickness 20 mils (0.5 mm) shall be used and make should be clearly stated in the offer along with test certificates.
- iii The core is to be securely clamped with heavy structural angle and should hold the entire core and coil assembly in place to ensure most efficient magnet circuit and quiet functioning of the transformer.
- iv **The successful bidder, shall be required to submit the manufacturer's test report showing the Watt Loss per kg and the thickness of the core plate, to ascertain the quality of Core materials.**
- v **The purchaser reserves the right to get tested at any Government recognized laboratory.**
- vi The transformer core shall not be saturated for any value of V/f ratio to the extent of 112.5% of the rated value of V/f ratio (i.e. 11000 / 50 or 22000/50) (due to combined effect of voltage and frequency) upto 12.5% without injurious heating at full load conditions and will not get saturated. The bidder shall furnish necessary design data in support of this situation.

6.2 Flux density:-

Flux density should not be more than 1.55 Tesla at the rated voltage and frequency. The maximum flux density at 112.5 % voltage and frequency shall not Exceed 1.9 Tesla. The value of the flux density allowed in the design shall be clearly stated in the offer along with graph.

6.3 The No Load current shall not exceed 1.5 % of the full load current. The no load current shall not exceed 3 % of the full load current in L. V. Winding when the applied voltage is 112.5%.

**TECHNICAL SPECIFICATION OF 100 kVA to 2500 kVA , 11/0.433 kV & 22/0.433 kV
DRY-TYPE (VPI) DISTRIBUTION TRANSFORMERS (Indoor and Outdoor).**

6.4 Coreclamping:

- a. M.S channel 125 mm x 65 mm for 100 & 200 kVA, 150 x 75 mm for 315 & 630 kVA transformer and 200 X 75 mm for 1000 kVA , 1250 KVA , 1600 Kva, 2000 KVA & 2500 KVA transformers on Top and Bottom.
- b. 16 mm dia, 2 nos High Tensile Bolts for 200 & 315 kVA and 20 mm dia, 2 nos High Tensile Bolts for 630, 1000, 1250 1600, 2000 & 2500 kVA in parallel at each end will be used.
- c. The top yoke channels to be reinforced by adequate size of M.S. flat with thickness not less than 6 mm, at equidistance if holes cutting is done for LT lead so as to avoid bending of channel.
- d. MS channels are to be painted by heat resistant paint.

6.5 Tie bolts:

- a. 8 nos. of tie rods of 20 mm. dia. high tensile steel in vertical formation.
- b. All top and bottom yoke nut bolts, if any, shall be MS and painted with heat and corrosion resistant paint before use.
- c. Drawing of the building of core to be approved before start of work.
- d. The base channels of the core shall not be cut channel.

6.6 Winding

A. H. V. & L. V. Coils

- i. Material – High conductivity Electrolytic copper.
- ii. **LV Winding** - Conventional spiral winding should be in even layers, so that Neutral shall be formed at top.
- iii. **Coil Insulation (HV/LV)** – Insulation shall be class ‘C’ conforming IS: 1271/1985 with vacuum pressure impregnated process in Varnish.
- iv. Coil spacers and duct – For sectional winding high temperature Epoxy fiberglass or porcelain and for disc winding epoxy fiberglass (Minimum class F insulation & above) shall be used.
- v. The inter –turns and end –turns of the HV & LV windings shall be insulated for protection against surges and transients.

B. Internal Connections:

a. H. V. Winding.

- i. In case of H. V. winding all jumpers from winding to bushing shall have cross-section larger than winding conductor.
- ii. Inter- coil connection shall be by crimping and brazing.

TECHNICAL SPECIFICATION OF 100 kVA to 2500 kVA , 11/0.433 kV & 22/0.433 kV DRY-TYPE (VPI) DISTRIBUTION TRANSFORMERS (Indoor and Outdoor).

- iii. In case of Copper Winding Delta joints shall be with Brazing only.
- iv. Lead from delta join shall be connected to bushing bus by brazing only.
- v. Lead from bushing bus bar to cable box bushing rod shall be bolted.
- vi. H. T. Line Bus shall be of EC grade copper flat having a cross – section of 25 X 6 sq.mm

b. L. V. Winding.

- i L. T. Star point shall be formed of Copper. Flat of sufficient length and cross section. Lead from winding shall be connected to the copper flat by brazing. Any other arrangement shall be subject to the approval of the Chief Engineer (Testing).
- ii Transformer L. T. winding connection to bus bar shall be by Brazing.
- iii L. T. Bus Bar used shall be suitable size & rating of Bushing / Insulator.

Lead from L. T. bus bar to cable box bushing shall be bolted. Use copper jumper of appropriate size of copper jumper. L. T. Line Bus Bar current density shall be 1.4 A /Sq. mm maximum.

6.7 Current Density:

6.7.1 Current density in HV and LV windings (Copper) should not be more than 1.4 A/sq.mm. (However, $\pm 5\%$ tolerance for LV winding is permissible).

6.7.2 Off Load Taps:

- a. The standard tapping ranges, when taps are provided, shall be as follows: Winding tapped : HV
- b. Number of tap positions 7
- c. Voltage variations : (+) 5 percent to (-) 10 percent in steps of 2.5 percent for variation of HV Voltage

6.7.3 For rating 1000 kVA and above ON Load tap changers shall be provided for variation of HV voltage from (+) 5% to (-) 15 % in steps of 2.5 %.

6.7.4 The standard tapping range and tapping steps arrangement shall not be required up to 630 KVA capacities.

6.7.5 Tapping Method: Off circuit tap-changing arrangement shall be either by means of links or by means of an externally-operated switch with mechanical locking device and a position indicator. Arrangement for pad-locking shall be provided.

**TECHNICAL SPECIFICATION OF 100 kVA to 2500 kVA , 11/0.433 kV & 22/0.433 kV
DRY-TYPE (VPI) DISTRIBUTION TRANSFORMERS (Indoor and Outdoor).**

6.7.6 Tap changing shall be carried out by means of an externally operated self position switch and when the transformer is in de-energised condition switch position No.1 shall correspond to the maximum plus tapping. Each tap change shall result in variation of 2.5 % in voltage. Provision shall be made for locking the tapping switch handle in position. Suitable aluminium anodized plate shall be fixed for tap changing switch to know the position number of tap.

6.7.8 The Transformer shall be capable of being operated without danger on any tapping at the rated kVA with voltage variation $\pm 10\%$ corresponding to the voltage of that tapping.

6.8 Losses:

6.8.1 The No Load & Full Load losses of transformers of 100,200, 315, 630, 1000 ,1250,1600,2000 &2500 KVA, 11 kV & 22kV class transformers at rated voltage at rated frequency are specified as shown in Table -1 as below subject to tolerance as per relevant IS: 2026.

TABLE - 1

Rating in KVA	Voltage Ratio in Volts			
	11000/ 433		22000/ 433	
	No load losses in watts.	Load losses in watts at 75 deg.C	No load losses in watts.	Load losses in watts at 75 deg.C
100	430	1600	480	1750
200	550	2350	600	2500
315	900	3200	950	3400
630	1250	3800	1350	4000
1000	1600	4600	1700	4850
1250	1800	6300	1900	6650
1600	2150	8300	2250	8750
2000	3000	9000	3200	9500
2500	3500	12000	3700	12600

6.8.2 The values given in G.T.P. for flux density, no load current at rated voltage, no load current at 112.5% of rated voltage and no load loss at rated voltage shall be individually met.

TECHNICAL SPECIFICATION OF 100 kVA to 2500 kVA , 11/0.433 kV & 22/0.433 kV DRY-TYPE (VPI) DISTRIBUTION TRANSFORMERS (Indoor and Outdoor).

6.9 Clearances:

- a. The minimum electrical clearance between the winding and body of the enclosure (between inside surface of the enclosure and outside edge of the winding) should be 100 mm. in case of 11 kV class and 150 mm in case of 22kV class transformers.
- b. End insulation toe arth
11 kV - 120 mm for all above rating transformers.
22 kV - 165 mm for all above rating transformers.
- c. Thickness of locking spacers and thickness of comb teeth between.
 HV coils – Minimum 10 mm. for 200, 315, 630 kVA and 15 mm for 1000 ,1250&1600 kVA transformers and 20 mm for 2000 & 2500 KVA , If Disc Winding between disc min 4 mm blocks
- d. Tap lead shall be insulated.
 Inspection of winding prior to assembly and connection shall be carried out. Manufacturing drawing for the transformer showing various clearances will have to be got approved from the M.S.E.D.C.L.
- e. Minimum external Clearances of Bushing Terminals:

i) For OUTDOOR type transformers

		11 kV	22 kV
HV	PH to PH	255 mm	325
	PH to E	205mm	240
LV	PH to PH	75 mm	75
	PH to E	50 mm	50

ii) For INDOOR TYPE Transformer (as per CBIP manual)

		<u>11 kV</u>	<u>22 kV</u>
HV	Ph to Ph	130 mm	241 mm
	Ph to E	80 mm	140 mm
LV	Ph-to-Ph	25 mm.	25 mm
	Ph to E	20 mm.	20 mm

6.10 Transformer Enclosure

The T/F enclosure shall be of robust construction and shall be built of electrically welded MS sheet wire mesh or perforated sheet for ventilation. All joints of enclosure and fitting shall be tight. The enclosure design shall be such that the core and winding can be lifted freely. The enclosure plates shall be of such strength that the complete transformer may be lifted bodily by means of the lifting lugs provided. The top cover shall have no cut at point of lifting lug.

The shape of the enclosure shall be rectangular only. No other shape will be accepted. The enclosure will be fabricated by welding at corners. The enclosure should comply with IP 43 protection as per IS: 2147 amended up to date. Horizontal or vertical joints in the enclosure side walls or its bottom or top cover will be allowed. The bottom plate of the enclosure shall be 2.5mm thick min and holes of 2.5 mm of diameter punched sheet for free air circulation.

A	Side wall thickness	2.5 mm.
B	Top and bottom plate thickness	2.5 mm
C	Lifting lugs	4 Nos. of heavy-duty eye bolt/lifting lugs suitable reinforces by vertical support shall be provided to main transformer core and winding assembly. 2 Nos. of heavy-duty eye bolt/lifting lugs of adequate size to transformer enclosure shall be provided.
D	Pulling lugs	4 Nos. of heavy duty pulling lugs shall be provided to pull the transformer horizontally.
E	Top cover-fixing bolts	GI nut bolts of ½” dia./screws with one plain washers shall be used for top cover fixing, spaced at 9” apart.
F	Bi- directional rollers of mild steel	4 Nos. 150 mm. diameter and 75mm. width for 200 & 315 transformers and 200 mm dia& -75 mm width for 630KVA, 1000 KVA,1250 KVA, 1600 KVA , 2000 KVA &2500 KVA Transformers

**TECHNICAL SPECIFICATION OF 100 kVA to 2500 kVA , 11/0.433 kV & 22/0.433 kV
DRY-TYPE (VPI) DISTRIBUTION TRANSFORMERS (Indoor and Outdoor).**

G	Transformer Base Channel	100 KVA – 75 X 40 mm MS Channel 200 KVA – 100 x 50 mm MSChannel. 315 KVA – 150 x 75 mm MSChannel. 630 KVA – 150 x 75 mm MS channel. 1000 kVA - 200X 75 mm MS Channel. 1250 KVA -200 X 75 mm MS Channel 1600 kVA – 200X 75 mm MSChannel. 2000 KVA – 200 X 75 mm MS Channel 2500 KVA – 200 X 75 mm MS Channel
---	--------------------------	--

7

H. T. & L. T. BUSHING:

7.1 Transformers HV and LV Bushings of Porcelain/ Epoxy of appropriate voltage and current ratings shall be mounted on opposite side of transformer tank in HV and LV cable box The high voltage bushings (3nos.) shall be provided with R-Y-B colour coding marking & shall conform to IS 2099.

The low voltage bushings shall conform to IS 7421. Alternatively, the low voltage cable box shall be made suitable for adoption of single core XLPE cables For 11 kV transformers, 12 kV rating & for 22 kV transformers, 24 kV rating HV Bushings shall be used and for 433 volts, 1 kV LV Bushings shall be used.

Bushings of the same voltage class shall be interchangeable. Bushing with same plain shades as per IS 3347 amended up to date shall be mounted on the side of the enclosure and not on the top cover. Only sheet metal pocket shall be provided for mounting of HV bushing and the same shall not be fixed on pipes. Sheet metal pocket shall be designed in such a way that all HT bushing shall be remain parallel and equidistance throughout. Bushing having type tested as per IS 3347 amended up to date shall only acceptable.

7.2

Minimum creepage distance for all HV or LV bushings shall not be less than 25 mm per kV.

**TECHNICAL SPECIFICATION OF 100 kVA to 2500 kVA , 11/0.433 kV & 22/0.433 kV
DRY-TYPE (VPI) DISTRIBUTION TRANSFORMERS (Indoor and Outdoor).**

**8 HT/LTCABLE BOXES FOR
100/200/315/630/1000/1250/1600/2000/2500 kVA
INDOORTYPE TRANSFORMERS:**

- a. H. T. & L. T. terminal for cable connections shall be brought out through side wall mounted Bushing to a cable end box.
- b. Cable end box shall be self-supporting, weatherproof, air filled type with sufficient space inside for termination and connection of cables.
- c. Cable end box shall be furnished complete with removable gland plate, double compression brass glands.
- d. In general, the arrangement shall be such as to permit of core & coil assembly without dismantling the cable installation.
 - i Suitable arrangement for HV side box and LV side box shall be provided. The LV cable box shall be suitable for terminating the cable, which will approach the boxes vertically from the bottom. The cable box shall be suitable for being detached from the main body with suitable mounting arrangement. The HV and LV cable box shall be fixed on the opposite sides.
 - ii The H. T. and L. T. cable box shall be fixed on the opposite sides.
- e. Rectangular shaped, M.S. Sheet thickness 2 mm , weather , vermin and dustproof HV/LV Cable box shall be fitted on opposite sides of the tank of transformer. (Indoor application) : as per details given below.
 - i For HV 22kV and 11kV:- Air filled cable box suitable for 3 core XLPE aluminum cables up to 300 sq.mm. & glands suitable for above cables .for LV 0.433 kV:- Air filled Cable Box suitable to single Core 300 sq.mm. XLPE aluminum cable i.e 2 cable run/Phase & 1 cable run for neutral for 315 kVA distribution transformer
 - ii Air filled Cable Box suitable to single Core 400 sq.mm. XLPE Aluminum cable i.e 3 cable run/Phase & 1 cable run for neutral for 630 kVA dist transformer
 - iii. for 315 kVA and above transformers, the LV Bushings shall be provided with suitable Aluminium Busbar Extensions to take off circuits with necessary nuts and bolts with resin cast support insulators. Separate Bushing for Earthing connection shall be provided to cable box with suitable wire mesh . The aluminiumnon magnetic gland plates shall be provided. In the case of indoor transformers, the enclosure shall be fitted with cable boxes on HV/LV sides as per the table given below.

TECHNICAL SPECIFICATION OF 100 kVA to 2500 kVA , 11/0.433 kV & 22/0.433 kV DRY-TYPE (VPI) DISTRIBUTION TRANSFORMERS (Indoor and Outdoor).

TABLE		
VOLTAGE	KVA	DETAILS
HV		
11000 or 22000	200,315,630,1000 ,1250 ,1600 ,2000& 2500	3 P-1G air filled cable box suitable for 3 core XLPE aluminium cables upto 300 sq.mm. & glands suitable for above cables.
LV		
433	200&315	4 P-2G Air filled cable box suitable to 3.5 C 185 sq.mm. PVC aluminum cable with copper flats fitted on LT studs to connect XLPE cable.
433	630, 1000 & 1600	4 P-3G Air filled cable box suitable to 3.5 C 300 sq.mm. PVC aluminum cable with copper flats fitted on LT studs to connect XLPE cable.

iii Cable gland suitable for HT/LT cable box shall be provided as follows:

Sr . No	Particulars	Cable size for H.T.	Cable size for L.T
1	200 kVA	3 core x 300 sq. mm XLPE cable	3 ½ core x 185 sq. mm. XLPE cable
2	315 kVA	3 core x 185 sq. mm XLPE cable	3 ½ core x 185 sq. mm. XLPE cable
3	630 kVA	3 core x 300 sq. mm. XLPE cable	3 ½ core x 300 sq. mm. XLPE cable
4	1000 kVA	3 core x 300 sq. mm. XLPE cable	3 ½ core x 300 sq. mm. XLPE cable
5	1600 kVA	3 core x 300 sq. mm. XLPE cable	3 ½ core x 300 sq. mm. XLPE cable

9. Bushing Terminals:

- a. Brass rods 12 mm. dia. for HT with necessary nuts, check nuts and plain thick tinned washers.
- b. Tinned copper rods 20 mm for 100 , 200 KVA , 30 mm. dia. for 315 & 630 KVA & 40 mm dia for 1000,1250 , 1600 & 2000 kVA,& 52 mm Dia. For 2500 KVA transformer for LT extension for cable lug connections, with necessary nuts, check nuts and plain thick tinned washers.

**TECHNICAL SPECIFICATION OF 100 kVA to 2500 kVA , 11/0.433 kV & 22/0.433 kV
DRY-TYPE (VPI) DISTRIBUTION TRANSFORMERS (Indoor and Outdoor).**

10. Terminal marking plates and ratingplates.

Terminals shall be provided with terminal marking plates. The transformer shall provide with riveted rating plate of minimum 18 SWG aluminum anodized material sheet in a visible position. The entries of the rating plate shall be indelibly marked (for example by etching, engraving or stamping).

The marking as 'M.S.E.D.C.L.' and 'Sr. No....' of Transformer will be engraved on Transformer enclosure, below L.T. Bushings.

The name of the company, order No., capacity, month and year of manufacturing shall be engraved on the enclosure of transformer just below the nameplate clearly visible. The engraving can be done on separate plate which shall be firmly welded to enclosure and shall form integral part of the enclosure.

11. TransformerFittings:

The Fittings on the transformers shall be as under:

1	Rating and diagram plate	1 No.
2	Earthing terminals with lugs	2 No.
3	Lifting lugs	2 Nos (for enclosure) and 4 nos for core & winding assembly
4	Platform mounting channel (With holes suitable for axle of roller)	2 Nos.
5	HV & LV Bushings	3 Nos of HV and 4 Nos of L.V Porcelain/Epoxy Bushing shall be provided with P.G. clamps as per relevant IS 3347 amended up to date.
6	Rollers	4 Nos.
7	Pulling lugs	4 Nos.
8	Cable Box	Only in case of indoor type transformers , HV & LV boxes with glands and connecting sockets as per tech spec cl. 8.1 &8.2

12 Testing and Inspection:-

12.1 Routine Tests:-

i. All transformers shall be subjected to the following routine tests at the manufacturer's works. The tests are to be carried out in accordance with the details specified in IS 2026 & IS:11171.

1. Measurement of winding resistance.

TECHNICAL SPECIFICATION OF 100 kVA to 2500 kVA , 11/0.433 kV & 22/0.433 kV DRY-TYPE (VPI) DISTRIBUTION TRANSFORMERS (Indoor and Outdoor).

2. Ratio, polarity and phase relationship.
 3. Impedance voltage.
 4. Load losses.
 5. No-load losses and No-load current.
 6. Insulation resistance.
 7. Induced over voltage withstand.
 8. Separate source voltages withstand.
- ii. All the routine tests shall be conducted in the suppliers' laboratory at their cost.
- iii. Temperature Rise test of the all above rating transformers shall be conducted on selected transformers from the 1st lot by Executive Engineer (Testing), MSEDCL. The temperature rise of all transformers when tested at rated current & rated voltage shall not exceed the limit indicated in Table -4 of IS: 11171 – 1985. The test shall be conducted as per Cl. No. 17.2.3 of IS: 11171 – 1985.
- iv. The calculations to confirm the thermal ability as per Clause no. Cl. No. 17.2.3 of IS: 11171 – 1985 shall be submitted with the offer.

13. Type Tests:-

- 13.1 In addition to routine test as above Impulse voltage Withstand test and Dynamic Short Circuit Test as under shall be successfully carried out at laboratories accredited by National Accreditation Board for Testing and Calibration Laboratories (NABL) in accordance with IS: 11171/1985 as amended upto date and this technical specifications, within the last 5 (five) years prior to the date of offer. The bidder shall furnish the following type tests reports (along with Rating and Diagram Plate, General arrangement drawing, Internal Constructional drawing & Technical details (Core & Core Assembly)) along with the offer.
- i. Impulse Voltage with stand Test on all three HV phases.
 - ii. Dynamic Short circuit Test
- 13.2 The following balance type test should be carried at the manufacturer's works invariably in the presence of M.S.E.D.C.L's representative at the time of inspection from the first lot.
- i. Temperature Rise Test.
 - ii. Unbalanced current test – unbalanced current should not be more than 2% of full load current
- 13.3 The type test reports should be submitted and got approved from the Chief Engineer (Testing) before commencement of supply.
- 13.4 In respect of the successful bidder, the purchaser reserves the right to demand repetition of some or all the type tests in presence of the purchaser's

TECHNICAL SPECIFICATION OF 100 kVA to 2500 kVA , 11/0.433 kV & 22/0.433 kV DRY-TYPE (VPI) DISTRIBUTION TRANSFORMERS (Indoor and Outdoor).

representative. In case the unit fails in the type tests, the complete supply shall be rejected.

14. Drawings :-

14.1 A set of following drawings shall be submitted by the Bidder along with the offer:

- i. General Arrangement drawing.
- ii. Internal construction
- iii. Technical Details (Core & Coil assembly details) drawing.
- iv. Rating & Diagram Plate Drawing.
- v. Details drawings of HV/LV Bushings indicating creepage distances.
- vi. Dimensional drawings showing the HV & LV cable boxes.
- vii. Transportation dimensions

14.2 The bidder should supply along with his offer the pamphlets/literatures etc. for fittings /accessories.

14.3 The bidder should not change design once offered as per A/T, Approved drawings and Type Test Reports.

14.4 The successful Bidders shall submit complete set of Drawings (as listed in Cl.No.23.1) of transformer indicating dimensions to CE (T&QC) for approval.

15 Rejection:-

15.1 Apart from rejection due to failure of the transformer to meet the specified test requirements the transformer shall be liable for rejection on any one of the following reasons.

- i. No load loss exceeds the values mentioned in Cl.. No. 6.8 above.
- ii. Load loss exceeds the specified values mentioned in Cl. No.6.8 above.
- iii. Impedance voltage value exceeds the Guaranteed value plus tolerances as mentioned at Cl..No.5.4 above.
- iv. Type test are not carried out as per clause no. 13 of the specification.
- v. Drawings are not submitted as per clause no. 14 of the specification.
- vi. GTP not submitted as per clause no. 17 of the specification.

16 Cleaning and Painting:-

- i. The surface of the enclosure shall be properly pre-treated /phosphated in a seven enclosure process and shall be applied with a powder coating of 40 microns thickness. The powder coating shall be of **Aircraft Blue** colour (**shade No. 108 as per IS 5**) for enclosure of transformers. Powder coating shall be suitable for outdoor use. The seven tank process facility shall be available with supplier to enhance to ensure proper quality of powder coating.

**TECHNICAL SPECIFICATION OF 100 kVA to 2500 kVA , 11/0.433 kV & 22/0.433 kV
DRY-TYPE (VPI) DISTRIBUTION TRANSFORMERS (Indoor and Outdoor).**

ii The month and year of supply shall be painted in **red bold Marathi** lettering at sum conspicuous place on the transformer, which shall be clearly visible from the ground.

17 Guaranteed Technical particulars for transformers:

To be filled in and submitted by the tenderer. The specific values shall be furnished and only quoting of IS reference “ as per the drawings enclosed “ “ as per M.S.E.D.C.L’s requirement or specification” etc will be considered as details not furnished and the offer shall be rejected.

18 Testing facility

The bidder should have adequate testing facility for all routine and acceptance tests and also arrangement for measurement of losses, resistance, etc. details of which will be enumerated in the tender.

The tenderer should also have **VPI plant**. M.S.E.D.C.L.’s Engineers will inspect and witness the process. The tenderer shall submit the details of Vacuum Pressure Impregnated (VPI) plant with offer.

The offer shall stand rejected if any of the Minimum Testing & Manufacturing Facilities as above in good working condition at the time of factory inspection are not available.

19 Stage Inspection:-

- 19.1 Supplier shall give 15 days’ advance intimation to the Chief Engineer (MMD) and S.E. (MMD) to organize stage inspection in which assembly of core, windings and other core materials etc. would be inspected. In respect to raw materials such as core stamping, winding conductor etc. successful bidder shall use these materials manufactured/supplied by the standard manufacturers and furnish the manufacturer's test certificates, as well as, proof of purchase from those manufacturers documentary evidence
- 19.2 Chief Engineer (MMD) will depute representatives from testing and inspection wing at the time of stage inspection.
- 19.3 10 % of the transformers from the offered lot will be tested for acceptance tests at factory, in the presence of purchaser's representative before dispatch.
- 19.4 The inspection may be carried out by the purchaser at any stage of manufacture. The successful bidder shall grant free access to the purchaser's representatives at a reasonable time when the work is in progress. Inspection and acceptance of any equipment under this specification by the purchaser shall not relieve the supplier of his obligation of furnishing equipment in accordance with the specifications and shall not prevent subsequent rejection if the equipment is found to be defective.
- 19.5 The purchaser may at its option, open a transformer supplied to the Stores, in presence of supplier at site or at Stores. If any of the technical particulars are seen to be in variance than the guaranteed technical particulars, the whole lot of transformer will be rejected without any liability on purchaser.

TECHNICAL SPECIFICATION OF 100 kVA to 2500 kVA , 11/0.433 kV & 22/0.433 kV DRY-TYPE (VPI) DISTRIBUTION TRANSFORMERS (Indoor and Outdoor).

19.6 In addition to the above, the purchaser may pick up any transformer and decide to get it type tested from any laboratory accredited by NABL at purchaser's cost. The Bidder will have to organize packing of the transformer at company's Stores for which they will be paid necessary charges. If the transformer fails to meet the requirement of type tests, the quantity of transformers ordered on them will be forthwith rejected and the purchaser may purchase these transformers at the risk and cost of the supplier.

20 Testing of all Distribution Transformers for no load and full load losses

After inspection of new transformers at factory for acceptance of the lot, all distribution transformers from the lot will be tested for no load and full load losses at all stores. Tenderer has liberty to be present at the time of testing.

22. Random Sample Testing (RST):

The tenderer should intimate to C.E. (MMD), M.S.E.D.C.L of completion of dispatches of whole lot of Distribution Transformers to stores against this tender. C.E. (MMD), M.S.E.D.C.L for will select the stores for Random Sample Testing (RST) and depute E.E. (Testing) to carry out RST of the lot.

E.E. (Testing) will select a transformer from the lot of transformers already tested for No load & full load losses. 15 days advance intimation will be given to tenderer for joint inspection. The date of RST will not be altered to the convenience or request of supplier. If supplier's representative fails to attend on the date fixed for RST, the RST will be carried out in his absence and results of RST will be binding on supplier. In case the selected transformer fails in any of the tests, complete lot of transformers will be rejected.

23 Quality Assurance

23.1 The bidder shall invariably furnish following information.

23.2 Certificates of following materials.

- i. Copper conductor
- ii. Core
- iv. Insulating paper.
- v. Porcelain Bushings
- vi Steel Plate used for Enclosure

23.3 Names of the supplier for the raw material, list of standard accordingly to which the raw materials are tested, list of test normally carried out on raw materials in presence of bidder's representatives, copies of type test certificates.

23.4 Information and copies of test certificate as in (i) above respect of bought out accessories including terminal connectors.

23.5 List of manufacturing facilities available. In this list the bidder shall specifically mention whether lapping machine, vacuum drying plant, air conditioned dust free room with positive air pressure for provision of insulation and winding etc are available with him.

23.6 Level of automation achieved and list of areas where manual processing still exists.

TECHNICAL SPECIFICATION OF 100 kVA to 2500 kVA , 11/0.433 kV & 22/0.433 kV DRY-TYPE (VPI) DISTRIBUTION TRANSFORMERS (Indoor and Outdoor).

- 23.7 List of areas in manufacturing process where stage inspection are normally carried out for quality control and details of such tests and inspections.
- 23.8 Special features provided in the equipments to make it maintenance free.
- 23.9 List of testing equipment available with the bidder to carry out all routine and acceptance tests on transformers
- 23.10 The successful bidder shall submit the Routine Test Certificate along with documentary evidence having paid for the excise duty for the following raw materials viz Copper for conductors, insulating materials, Core materials, Bushing at the time of routine Testing of the fully assembled transformer.

24 Qualifying Requirement: As per tender

25 Performance Guarantee:

All transformers supplied against this specification shall be guaranteed for a period of 66 months from the date of receipt at the consignee's Stores Center or 60 months from the date of commissioning, whichever is earlier. However, any engineering error, omission, wrong provisions, etc. which do not have any effect on the time period, shall be attended to as and when observed/ pointed out without any price implication.

26 Final Inspection

10 % of the transformers offered will be tested for all tests without opening the transformer. Heat Run Test will have to be carried out on the transformer having maximum no load and full load losses taken together. Chief Engineer (MMD) will depute representatives from testing and inspection wing at the time of final inspection.

27 Schedules

- 27.1 The bidder shall fill in the following schedules which form part of the tender specification and offer. If the schedules are not submitted duly filled in with the offer, the offer shall be rejected.

Schedule `A' -Guaranteed Technical
Particulars

- 27.2. The Bidder shall submit the list of orders for similar type of equipments, executed of under execution during the last three years, with full details in the schedule of Tenderer's experience (Schedule `B') to enable the purchaser to evaluate the tender.

**TECHNICAL SPECIFICATION OF 100 kVA to 2500 kVA , 11/0.433 kV & 22/0.433 kV
 DRY-TYPE (VPI) DISTRIBUTION TRANSFORMERS (Indoor and Outdoor).**

Schedule 'A' - Guaranteed Technical Particulars.

**For 100/200/315/630/1000/1250/1600/2000/2500 kVA Dry
 Type Distribution Transformers**

SR. NO.	GTP PARAMETERS	REMARK
1	Name of Manufacturer	TEXT
2	Reference Standards	TEXT
3	Transformer shall be Dry (VPI) Air Natural Air Natural (ANAN) type Yes/No	BOOLEAN
4	Transformer shall be suitable for Outdoor/ Indoor installation Yes/No	BOOLEAN
5	KVA rating of the transformer	NUMERICAL
6	Primary Voltage in KV	NUMERIC
7	Secondary Voltage in KV	NUMERIC
8	Method of connection for H.V. Winding shall be Delta : Yes/No.	BOOLEAN
9	Method of connection for L.V. Winding shall be Star : Yes/No	BOOLEAN
10	Connection Symbol shall be Dyn-11 (Yes/No)	BOOLEAN
11	By resistance method Maximum temperature rise of Windings over an Ambient temp. of 50°C in °C	NUMERIC
12	The temperature shall in no case reach a value that will damage the core itself ,other parts or adjacent materials (Yes/No)	BOOLEAN
13	Estimated maximum hot spot Temperature in deg. Centigrade	NUMERIC
14	Whether neutral is solidly earthed (Yes /No)	BOOLEAN
15	Magnetizing current (in amps) at rated voltage and rated frequency & its % with full load current	TEXT
16	Magnetizing current at maximum voltage (112.5% of rated voltage) and rated frequency (in amps) & its % with full load current	TEXT
17	Flux density at normal voltage and frequency in Tesla	TEXT
18	Approximate length of the Transformer in mm	NUMERIC
19	Approximate breadth of the Transformer in mm	NUMERIC
20	Approximate height of the Transformer in mm	NUMERIC
21	Approximate length of the Transformer tank in mm	NUMERIC
22	Approximate breadth of the Transformer tank in mm	NUMERIC
23	Approximate height of the Transformer tank in mm	NUMERIC
24	Minimum thickness of the side of transformer tank plates in mm	NUMERIC
25	Minimum thickness of the bottom of transformer tank plates in mm	NUMERIC
26	Minimum thickness of the cover of transformer tank plates in mm	NUMERIC
27	Shape of main enclosure of transformer	TEXT

**TECHNICAL SPECIFICATION OF 100 kVA to 2500 kVA , 11/0.433 kV & 22/0.433 kV
 DRY-TYPE (VPI) DISTRIBUTION TRANSFORMERS (Indoor and Outdoor).**

28	Current density of HV winding at any Tap, in Amps/sq. mm.	TEXT
29	Current density of LV winding, in Amps / sq.mm.	TEXT
30	Minimum cross section of Copper used in HV Winding	TEXT
31	Minimum cross section of Copper used in LV Winding in sq. mm	TEXT
32	Approximate Weights of Core Laminationskgs	NUMERIC
33	Approximate Weights of Copper (Windings): kgs	NUMERIC
34	Approximate Weights of Transformer core and windings :kgs	NUMERIC
35	Approximate Weights of Tank & fittings: kgs	NUMERIC
36	Type of Core	TEXT
37	No. of H.V. disc (coils) per phase (per limb)	TEXT
38	Colour of transformer enclosure	TEXT
39	Name plate provided with all details as per the specifications (Yes/No)	BOOLEAN
40	No of steps used in CRGO Core	NUMERIC
41	Thickness of core lamination inmm	TEXT
42	Diameter of the core (in mm)	TEXT
43	Core material & grade of laminations used	TEXT
44	Effective Core Area (Sq.mm)	TEXT
45	Overload capacity of transformers for 2 hrs.	TEXT
46	No load losses at normal voltage and frequency in Watts	NUMERIC
47	Load Losses at rated voltage at 75 deg. Centigrade in Watts	NUMERIC
48	Total losses (No Load + Load Losses at 75 deg C)	NUMERIC
49	Resistance of HV winding at 20 ° C in Ohm/phase	TEXT
50	Resistance of LV winding at 20 ° C in Ohm/phase	TEXT
51	No of HV Turns	NUMERIC
52	No of LV Turns	NUMERIC
53	Voltage per turn used in HV/LV winding for design	NUMERIC
54	Whether end insulation is provided to the end turns	BOOLEAN
55	Percentage of voltage of end turns with reinforced insulation	TEXT
56	Type of insulation on HV conductors	TEXT
57	Type of insulation on LV conductors	TEXT
58	Type of insulation on LV to core	TEXT
59	Type of insulation on Core Bolts	TEXT
60	Type of insulation on Core Bolt Washers	TEXT
61	Type of insulation on Core Lamination	TEXT
62	Manufacturer's name of HV Bushings:	TEXT
63	Material of HVBushings	TEXT
64	Rating of HV Bushing	TEXT
65	Min. clearance between phase to earth of secondary winding	TEXT
66	Min Width of the duct between LV & HV windings (in mm)	TEXT
67	1 Minute Power frequency withstand voltage (Dry)at 50 Hz of HV	TEXT

**TECHNICAL SPECIFICATION OF 100 kVA to 2500 kVA , 11/0.433 kV & 22/0.433 kV
 DRY-TYPE (VPI) DISTRIBUTION TRANSFORMERS (Indoor and Outdoor).**

	Bushings	
68	1 Minute Power frequency withstand voltage (Wet) at 50 Hz of HV Bushings	TEXT
69	Impulse Flash over voltage kV (stating the wave form adopted) of HV winding	TEXT
70	Minimum Creepage Distance of HV Bushings in mm	
71	Material of LV Bushings:	TEXT
72	Rating of LV Bushing : 1 kV, 250 A.	TEXT
73	Manufacturer's name of LV Bushings:	TEXT
74	Minimum Creepage Distance of LV Bushings in mm	TEXT
75	Efficiency at 75 deg. centigrade at unity p.f at 100 % Load	TEXT
76	Efficiency at 75 deg. centigrade temperature at unity p.f at 75 % Load	TEXT
77	Efficiency at 75 deg. centigrade temperature at unity p.f at 50 % Load	TEXT
78	Efficiency at 75 deg. centigrade temperature at unity p.f at 25 % Load	TEXT
79	Efficiency at 75 deg. centigrade temperature at unity p.f at 125 % Load	TEXT
80	Efficiency at 75 deg. centigrade temperature at 0.8 p.f lag at 100 % Load	TEXT
81	Efficiency at 75 deg. centigrade temperature at 0.8 p.f lag at 75 % Load	TEXT
82	Efficiency at 75 deg. centigrade temperature at 0.8 p.f lag at 50 % Load	TEXT
83	Efficiency at 75 deg. centigrade temperature at 0.8 p.f lag at 25 % Load	TEXT
84	Efficiency at 75 deg. centigrade temperature at 0.8 p.f lag at 125 % Load	TEXT
85	Efficiency at 75 deg. centigrade temperature at 0.8 p.f leading at 100 % Load	TEXT
86	Efficiency at 75 deg. centigrade temperature at 0.8 p.f leading at 75 % Load	TEXT
87	Efficiency at 75 deg. centigrade temperature at 0.8 p.f leading at 50 % Load	TEXT
88	Efficiency at 75 deg. centigrade temperature at 0.8 p.f leading at 25 % Load	TEXT
89	Efficiency at 75 deg. centigrade temperature at 0.8 p.f leading at 125 % Load	TEXT
90	% impedance at 75 deg C	TEXT
91	Regulation at 0.8 p.f. lag (in %)	TEXT

**TECHNICAL SPECIFICATION OF 100 kVA to 2500 kVA , 11/0.433 kV & 22/0.433 kV
DRY-TYPE (VPI) DISTRIBUTION TRANSFORMERS (Indoor and Outdoor).**

92	Regulation at 0.8 p.f. leading (in %)	TEXT
93	Lifting Lugs provided to transformer and transformer enclosure	Text
94	Pulling Lugs provided to transformer	Text
95	Transformer Earthing terminals size and no	Text
96	Transformer Rollars size and nos	Text
97	Overall Dimensions of HV Cable box	Text
98	Overall Dimensions of LV Cable box	Text
99	The test certificates of copper conductors, core material, insulation paper, porcelain Bushings, steel plate used for enclosure of the offered transformer are enclosed with the offer in physical format with soft copy (Yes/No)	BOOLEAN
100	All type test reports of type tests carried out on transformer as per IS:2026 & tech. specifications at NABL laboratory shall be submitted with the offer in physical format & with soft copy (Yes/No)	BOOLEAN
101	Unbalanced current test & temperature rise test shall be conducted at your works format enclosed with the technical specification & IS:2026 alongwith the offer with soft copy (Yes/NO)	BOOLEAN
102	Testing facility, Plant & machinery , list of order executed /under execution shall be furnished separately in physical format & with soft copy alongwith the offer (Yes/No)	BOOLEAN
103	The information required under Quality Assurance shall be submitted with the offer in physical format & soft copy (Yes/No)	BOOLEAN
104	The cost data in prescribed format shall be submitted with the offer in physical format & soft copy (Yes/No)	BOOLEAN
105	The performance Guarantee of the transformers in years	NUMERIC

**TECHNICAL SPECIFICATION OF 100 kVA to 2500 kVA , 11/0.433 kV & 22/0.433 kV
DRY-TYPE (VPI) DISTRIBUTION TRANSFORMERS (Indoor and Outdoor).**

**Annexure I
Unbalance Current Test**

Name of

Supplier:

Order No.:

Capacity & Voltage Ratio of Distribution Transformer: _____ kVA,
_____/0.433 kV

Vector Group Dyn11

Sr. No. of equipment Tested:

Date of Testing:

Reference Standard

Transformer Secondary terminals 2U, 2V & 2W are shorted. The shorted 2U, 2V & 2W is connected to 2N through Ammeter. The primary terminals 1U, 1V & 1W are connected to supply. The rated current A is fed to primary and unbalance current is noted on Ammeter.

Unbalance Current Measured in Ammeter:

_____ A

Rated current in Secondary Side: _____ A

Permissible limits as per specification : 2% of the Rated current in Secondary Side

% of Unbalance current with reference to Rated current in Secondary Side

$$= \frac{\text{Unbalance Current} \times 100}{\text{Rated current in Secondary Side}}$$

=

=

Test witnessed by

Tested by

**TECHNICAL SPECIFICATION OF 100 kVA to 2500 kVA , 11/0.433 kV & 22/0.433 kV
DRY-TYPE (VPI) DISTRIBUTION TRANSFORMERS (Indoor and Outdoor).**

**Annexure II
Temperature Rise Test**

Name of Supplier:
Order No.:
Capacity & Voltage Ratio of Distribution Transformer: _____ kVA,
_____/0.433 kV

Vector Group Dyn 11
Sr. No. of equipment
Tested: Date of Testing:
Reference Standard

	H.V. Winding	L. V. Winding
Rated Line Current in Amp		

Guaranteed No Load Losses _____ watt

Load Losses _____ watt

Total Losses _____ watt

P. T. Ratio: _____ / _____ =

C. T. Ratio: _____ / _____ =

Wattmeter Constant =

Total Multiplying Factor (MF) =

TIME	Ambient Temp.				Line Voltage in Volts	Line Current in Amps	W1 watts	W2 watts	W3 watts	W1+W2+W3 watt	Multiplying Factor (MF)	Total Watt
	T1 °C	T2 °C	T3 °C	Average °C								

**TECHNICAL SPECIFICATION OF 100 kVA to 2500 kVA , 11/0.433 kV & 22/0.433 kV
DRY-TYPE (VPI) DISTRIBUTION TRANSFORMERS (Indoor and Outdoor).**

**TECHNICAL SPECIFICATION OF 100 kVA to 2500 kVA , 11/0.433 kV & 22/0.433 kV
 DRY-TYPE (VPI) DISTRIBUTION TRANSFORMERS (Indoor and Outdoor).**

Calculation of Temperature Rise in

Winding Temperature Rise in LV

Winding=_____°C

HV Winding Resistance across 1U1V at__°C =

_____ohm

Measurement of Hot Resistance of HV Winding after
 ShutDown.

Time	Resistance

Hot winding Resistance at Ambient Temperature__°C (from graph)=

_____ Ohm Temperature Rise in

H. V. Windings

$$= \frac{\text{Hot Resistance} \times (235 + \text{Cold Ambient Temperature})}{\text{Cold Resistance}} - (235 + \text{Hot Ambient Temperature})$$

**TECHNICAL SPECIFICATION OF 100 kVA to 2500 kVA , 11/0.433 kV & 22/0.433 kV
DRY-TYPE (VPI) DISTRIBUTION TRANSFORMERS (Indoor and Outdoor).**

=

=

Results :

- 1) Temperature Rise in LV Winding = _____ °C
- 2) Temperature Rise in HV Winding = _____ °C

Test witnessed by

Tested by

∅6
4HOLES

DRY (VPI) TYPE DISTRIBUTION TRANSFORMER

MANUFACTURER SR. NO.	TPE-	REF. STD : IS-11171 & 2026
KVA		TYPE OF COOLING
VOLTS AT NO LOAD	{ HV LV	FREQUENCY
		IMPEDANCE VOLTS (%)
AMPERES	{ HV LV	VECTOR GROUP REFERENCE
		CORE WEIGHT Kgs.
PHASES	{ HV LV	WINDING WEIGHT Kgs.
		ENCLOSURE & FITTINGS Kgs.
YEAR OF MANUFACTURE		TOTAL WEIGHT Kgs.
WDG. INSULATION CLASS :	MAXIMUM TEMPERATURE RISE IN WINDING : WITH AND AMBT. °C	
GUARANTEED NO LOAD LOSS		
GUARANTEED LOAD LOSS		
INSULATION LEVEL :-		

55
156
245

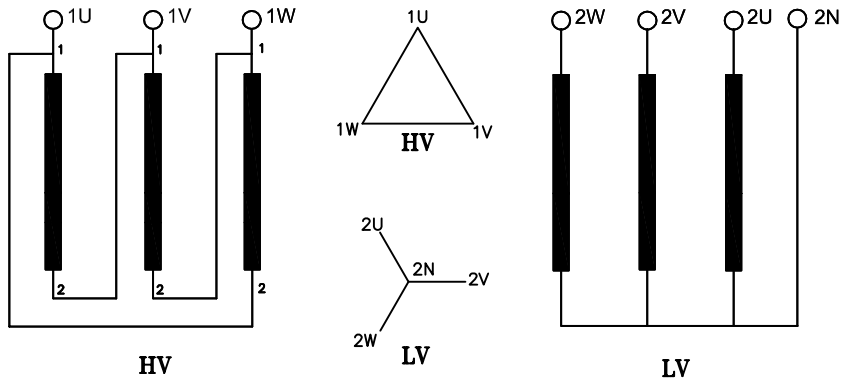

VECTOR GROUP Dyn11.

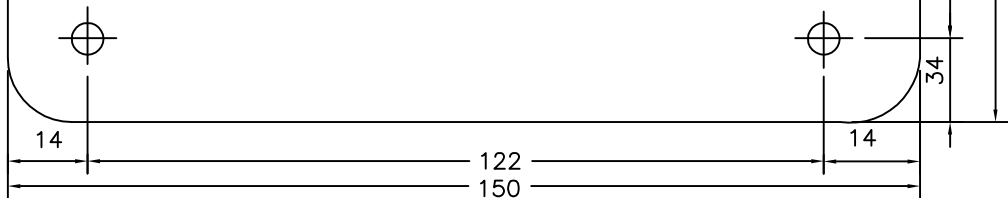

THESE ARE INDICATIVE DRAWINGS.

ALL DIMS. ARE IN M.M., EXCEPT STATED.		SCALE	ORDER No.	
TITLE :-		NTS		
			NAME	SIGN. DATE
CLIENT	MARASHTRA STATE ELECTRICITY DIST. CO. LTD	DRN. BY		
SCHEME		CHD. BY		
		APP. BY		
		DRG. NO. :-	SHEET	1 OF 1 REV.
				RO
PATH				Size-A4

F

F

5	6	7	8
REV	DESCRIPTION	REV BY	CHD BY
R0	ORIGINAL DRAWING.		
		APP BY	DATE

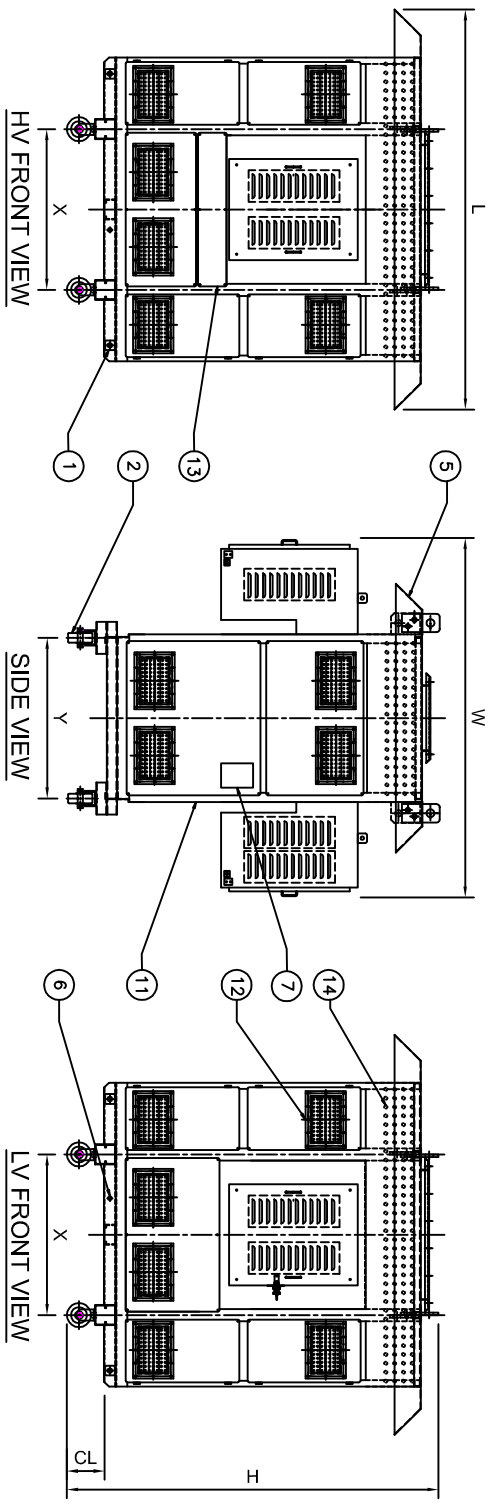
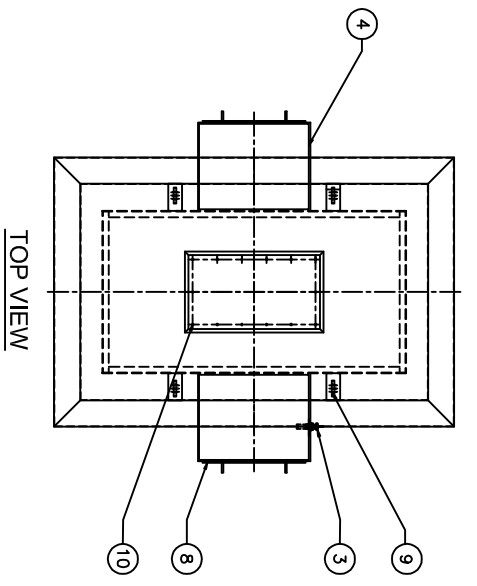

MIN. CLEARANCE (INDOOR)	
PH. TO PH.	PH. TO EARTH.
HV	
LV	

OVERALL DIMENSIONS				
KVA	V/R	L	W	H
		X		Y

WEIGHT DETAILS :- (IN kg)	
1. WGT. OF CORE	
2. WGT. OF WINDING	
3. WGT. OF ENCLOSURE & FITTINGS	
TOTAL WEIGHT	

ENCL. DIMENSIONS		
L	B	H

TECHNICAL DATA :-
 RATING :
 1) RATED POWER :
 2) RATED VOLTAGE :
 3) VECTOR GROUP :
 4) TYPE OF COOLING :
 5) FREQUENCY :

ITEM NO.	DESCRIPTION	QTY.
14	PERFORATED SHEET	-
13	TAP LINK OPERATION DOOR	1 NO.
12	LOUVERS	VAR
11	ENCLOSURE	1 NO
10	PROVISION OF DUCT FOR AIR EXHAUST	1 NO
9	LIFTING LUGS	4 NOS
8	LV CABLE BOX	1 NO
7	RATING & DIAGRAM PLATE	1 NO
6	EARTHING TERMINALS	2 NOS
5	CANOPY	1 NO
4	HV CABLE BOX	1 NO
3	ADDITIONAL NEUTRAL	VAR.
2	FLAT BI-DIRECTIONAL ROLLERS	4 NOS
1	UNDER-CARRIAGE HAULAGE WITH HOLES	4 NOS

BILL OF MATERIAL

ALL DIMS. ARE IN M.M., EXCEPT STATED.		SCALE	ORGR.NG.
TITLE :-		N/S	-
CUSTOMER	MAHARASHTRA STATE ELECTRICITY DIST. CO. LTD	DRN. BY	NAME
SCHEME		CHD. BY	SGN.
		APPD. BY	DATE
		DRG. NO. :-	SHEET 1 OF 1
			REV.
			R-0
			SIT-43

THESE ARE INDICATIVE DRAWINGS.

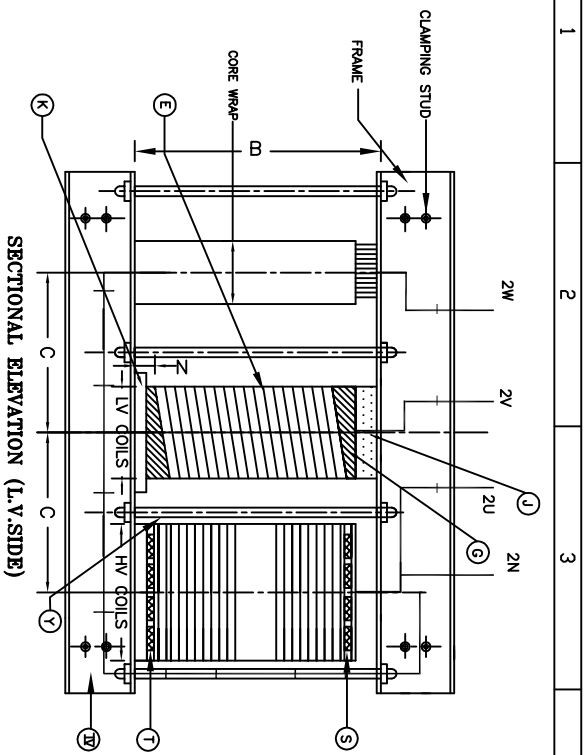

SECTIONAL ELEVATION (L.V. SIDE)

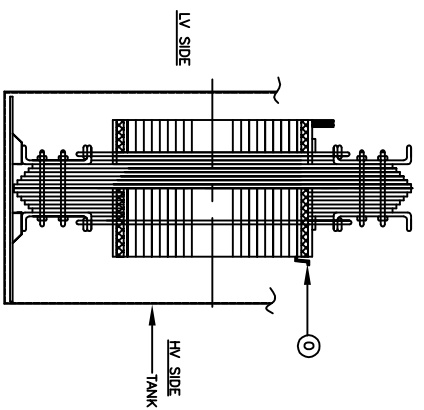

SECTIONAL END VIEW

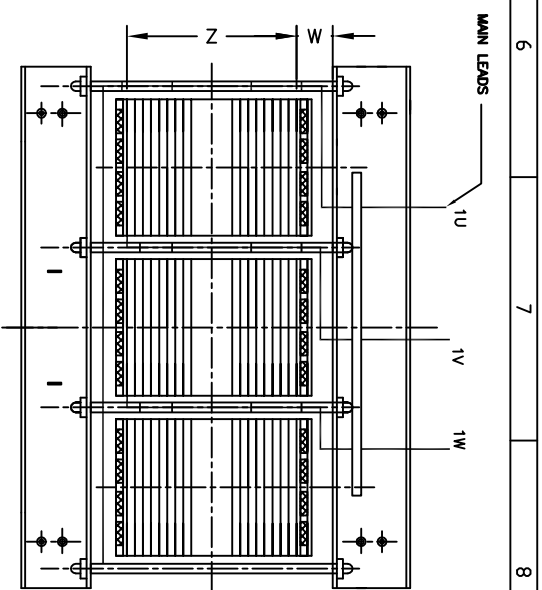

ELEVATION (H.V. SIDE)

I	CORE DETAILS	SIZE
A	CORE CIRCLE	
B	WINDOW HEIGHT	
C	LEG CENTERS	
D	YOKE SIZE	
II		
L. V. WINDING		
E	CONDUCTOR C/S AREA	
F	No. OF LAYERS	
G	INSULATION BETWEEN LAYERS	
H	INSIDE DIAMETER	
I	OUT SIDE DIAMETER	
J	INSULATION TOP	
K	INSULATION BOTTOM	
L	INSULATION OVER LV	
M	CLEARANCE BET LV (SEC) TO EARTH BARE	
III		
H. V. WINDING		
N	CONDUCTOR C/S AREA OF MAIN WDG.	
O	No. OF COILS /PHASE	
P	BLOCK BETWEEN COILS	
Q	INSIDE DIAMETER	
R	OUT SIDE DIAMETER	
S	INSULATION TOP	
T	INSULATION BOTTOM	
U	CLEARANCE BETN END INSULATION TO EARTH	
V	CLEARANCE BETWEEN CORE & LV	
W	CLEARANCE BETWEEN END INSULATION TO EARTH	
X	PHASE BARRE THICKNESS	
Y	COPPER TO COPPER HEIGHT	
Z	FRAME SIZE	
AA	FLUTCH PLATE	
AB	BLOCK PER CIRCLE	

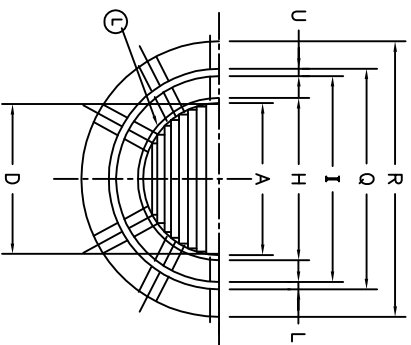

THESE ARE INDICATIVE DRAWINGS.

ALL DIMS. ARE IN M.M., EXCEPT STATED.

TITLE :-

CLIENT	MAHARASHTRA STATE ELECTRICITY DIST. CO. LTD.	SCALE	ORDER NO.
SCHEME		N/S	
		DRN. BY	
		CHD. BY	
		APPD. BY	
		DRG. NO. :-	SHEET 1 OF 1
			REV.
			R-0

PATH

SIZE-A3

Sr.NO	DISCRPTION	AS OFFERED
1	PRIMARY VOLTAGE	
2	SECONDARY VOLTAGE	
3	RATING (KVA)	
4	VECTOR GROUP	
5	CONFIRMING TO IS	
6	PERMISSIBLE VOLTAGE FLUCTUATION(%)	
7	TEMP OF WINDING (MAX)*C	
8	CORE DETAILS	
	d)CORE MATERIAL	
	b)PRINCIPAL SOURCE OF MATERIAL	
	c)GRADE OF LAMINATION(THICKNESS)	
	d)FLUX DENSITY W/M	
	e)NO OF STEPS OF CORE	
	f)TYPE OF CORE	
	CORE WEIGHT(IN KG)	
9	% IMPEDANCE	
10	CORE DIMENSION (CD/WH/LC)	

Sr.NO	DISCRPTION	AS OFFERED
12	WINDING	HV LV
	d)MATERIAL	
	b)CONDUCTOR SIZE mm	
	c)GROSS SECTION AREA	
	d)INSULATION MATERIAL	
	e)CURRENT DENSITY(A/sq.mm) max	
	f)NOS. OF TURNS	
	g)OUTER DIA mm	
	h)INSIDE DIA mm	
	i)AXIAL LENGTH mm	
	j)NO OF COIL PER PHASE	
	k)RESISTANCE/PHASE ohm at 20DegC	
13	BUSHING	
	MINIMUM CREEPAGE DIST.	
14	NO LOAD LOSSES (watt)	
	LOAD LOSSES AT 75 deg C (watt)	
	TOTAL LOSSES AT 75 deg C (watt)	
15	TANK	
	SIDE WALL THICKNESS mm	
	TOP & BOTTOM PLATE mm	
	SIDE WALL THICKNESS mm	

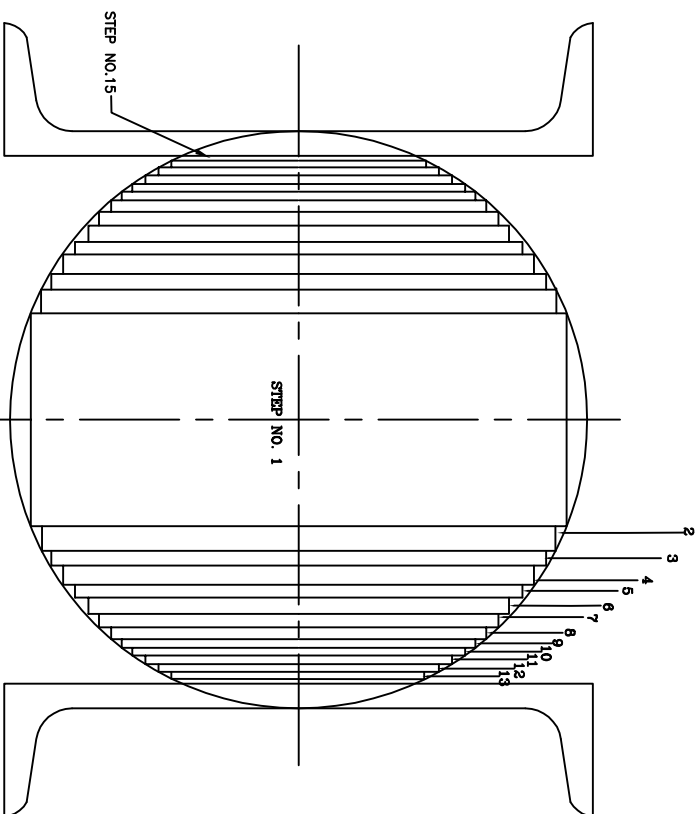

STEP No.	1	2	3	4	5	6	7	8	9	10	11	12	13	14	15
L. mm															
STACK THICKNESS															
CROSS SECTION cm ²															

TOTAL CROSS SECTION AREA = cm²
EFFECTIVE CORE AREA = cm²

THESE ARE INDICATIVE DRAWINGS.

ALL DIMS. ARE IN M.M., EXCEPT STATED.		SCALE	ORDER NO.
TITLE :-		NTS	
CLIENT	MAHARASHTRA STATE ELECTRICITY DIST. CO. LTD.	DRN. BY	
SCHEME		CHD. BY	
		APPD. BY	
		DRG. NO. :-	SHEET 1 OF 1
		REV.	R-0
PATH		SIZE-A3	

DESCRIPTION	CREEPAGE DIST.
FROM S - A	85 mm
FROM A - B	85 mm
FROM B - F	130 mm
TOTAL S - F	300 mm

TECHNICAL DATA	
TYPE:- OIL COMMUNICATING, SOLID PORCELAIN TYPE	
RATED VOLTAGE	= 12 kV
RATED CURRENT	= 250 AMP.
P.F. WITHSTAND VOLTAGE(DRY & WET)	= 28 kV
LIGHTNING IMPULSE WITHSTAND VOLTAGE	= 75 kVp
TOTAL CREEPAGE DISTANCE(25mm/kV)	= 300 mm
TOTAL WEIGHT	= 4kg.Approx.
COLOUR	= BROWN

ITEM	QTY.	DESCRIPTION
1	1	INSULATOR
2	1	LEAD CONNECTOR
3	1	CAP
4	1	SEALING WASHER FOR STEM
5	1	SEPARATOR
6	1	SEALING WASHER
7	3	HEXAGONAL NUT(FOR STEM)
8	1	STEM
9	1	WASHER
10	1	CLAMPING MEMBER
11	1	CLAMPING RING

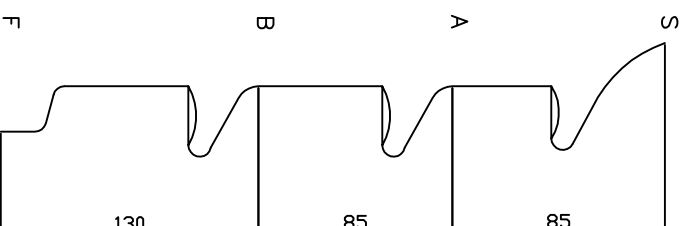

CREEPAGE DIST. (S TO F)=300MM

THESE ARE INDICATIVE DRAWINGS.

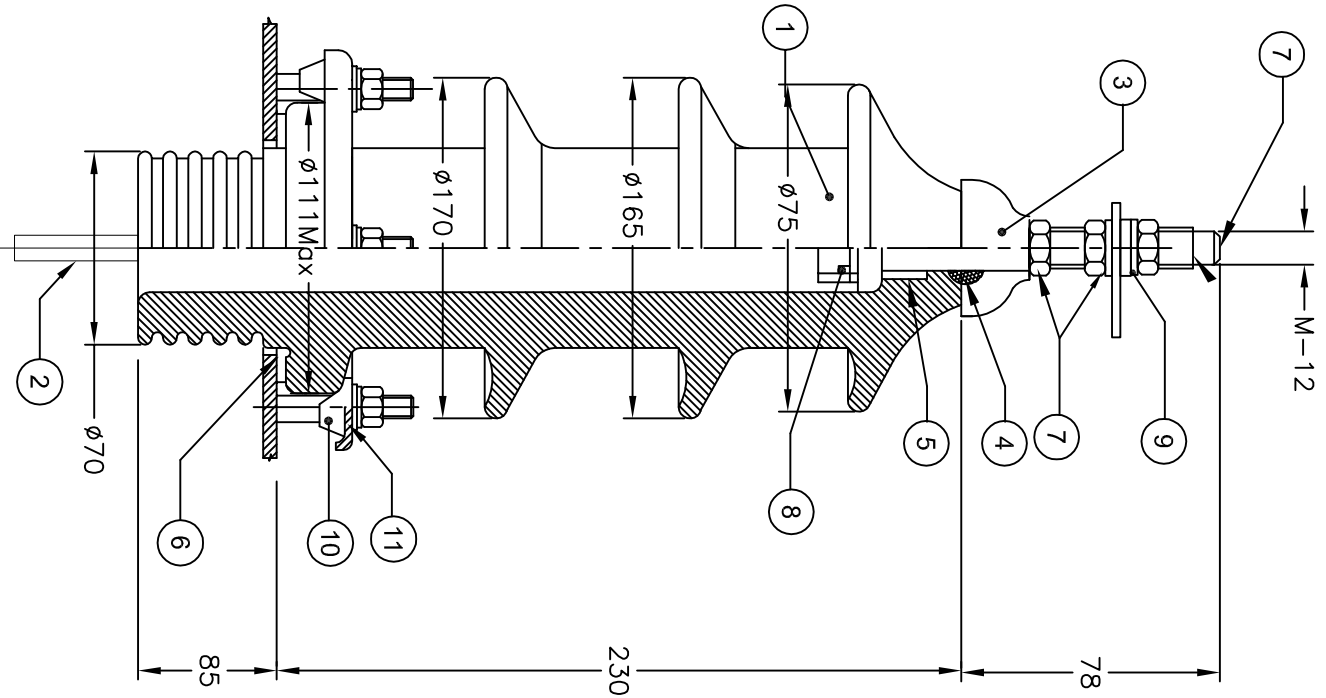

ALL DIMS. ARE IN M.M., EXCEPT STATED.		SCALE	ORDER NO.
TITLE :-		NTS	-
CLIENT	MAHARASHTRA STATE ELECTRICITY DIST. CO. LTD.	DRN. BY	
SITE		CHD. BY	
		APPD. BY	
DRG. NO. :-		SHEET 1 OF 1	REV.
PATH			R-0

SIZE-A3

TECHNICAL DATA

TYPE: -	OIL COMMUNICATING, SOLID PORCELAIN TYPE
RATED VOLTAGE	= 1.1 kV
RATED CURRENT	= 1000 AMP.
P.F. WITHSTAND VOLTAGE(DRY & WET)	= 5/4 kV
CREEPAGE DISTANCE(25mm/kV)	= 66 mm
TOTAL WEIGHT	= 6.7kg, Approx.
COLOUR	= BROWN

PARTICULARS	CREEPAGE DISTANCE
F-A	20
A-B	36
B-S	10
TOTAL CREEPAGE DISTANCE	F-S=66 mm

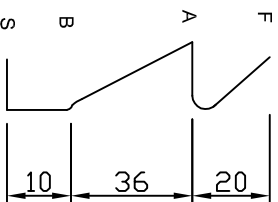

CREEPAGE DIST.(F TO S)
= 66mm

ITEM	QTY.	DESCRIPTION
1	1	INSULATOR UPPER
2	1	INSULATOR LOWER
3	1	STEM (30 MM)
4	1	TOP END WASHER
5	1	STEM WASHER
6	1	BOTTOM NUT
7	1	SEALING WASHER (STEM)
8	1	SEALING WASHER
9	1	SEALING WASHER
10	1	SEALING GASKET
11	3	HEX LOCK NUT
12	2	HEX LOCK NUT
13	3	PLAIN WASHER M12
14	1	SEALING WASHER

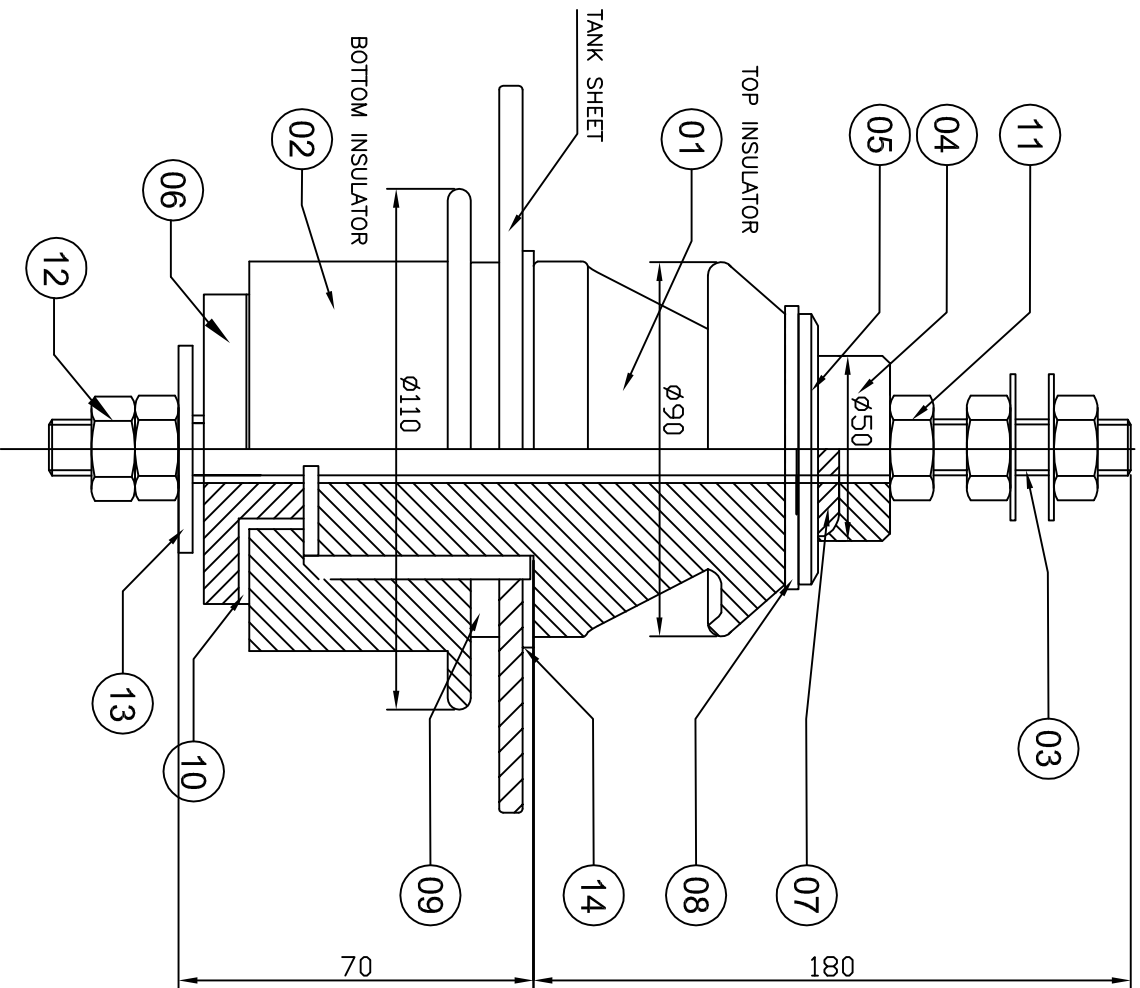

THESE ARE INDICATIVE DRAWINGS.

ALL DIMS. ARE IN M.M., EXCEPT STATED.

TITLE: _____

CLIENT	MAHARASHTRA STATE ELECTRICITY DIST. CO. LTD.	SCALE	ORDER NO.	DATE
SCHEME		DRN. BY		
		CHD. BY		
		APPD. BY		
		DRG. NO.:	SHEET 1 OF 1	REV.

PATH		SIZE-A3
		R-0

5	REV	DESCRIPTION	6	REV BY	CHD BY	APP BY	8	DATE
R0	ORIGINAL DRAWING.							

HV CLEARANCES (minimum)	
PH. TO PH.	PH. TO EARTH

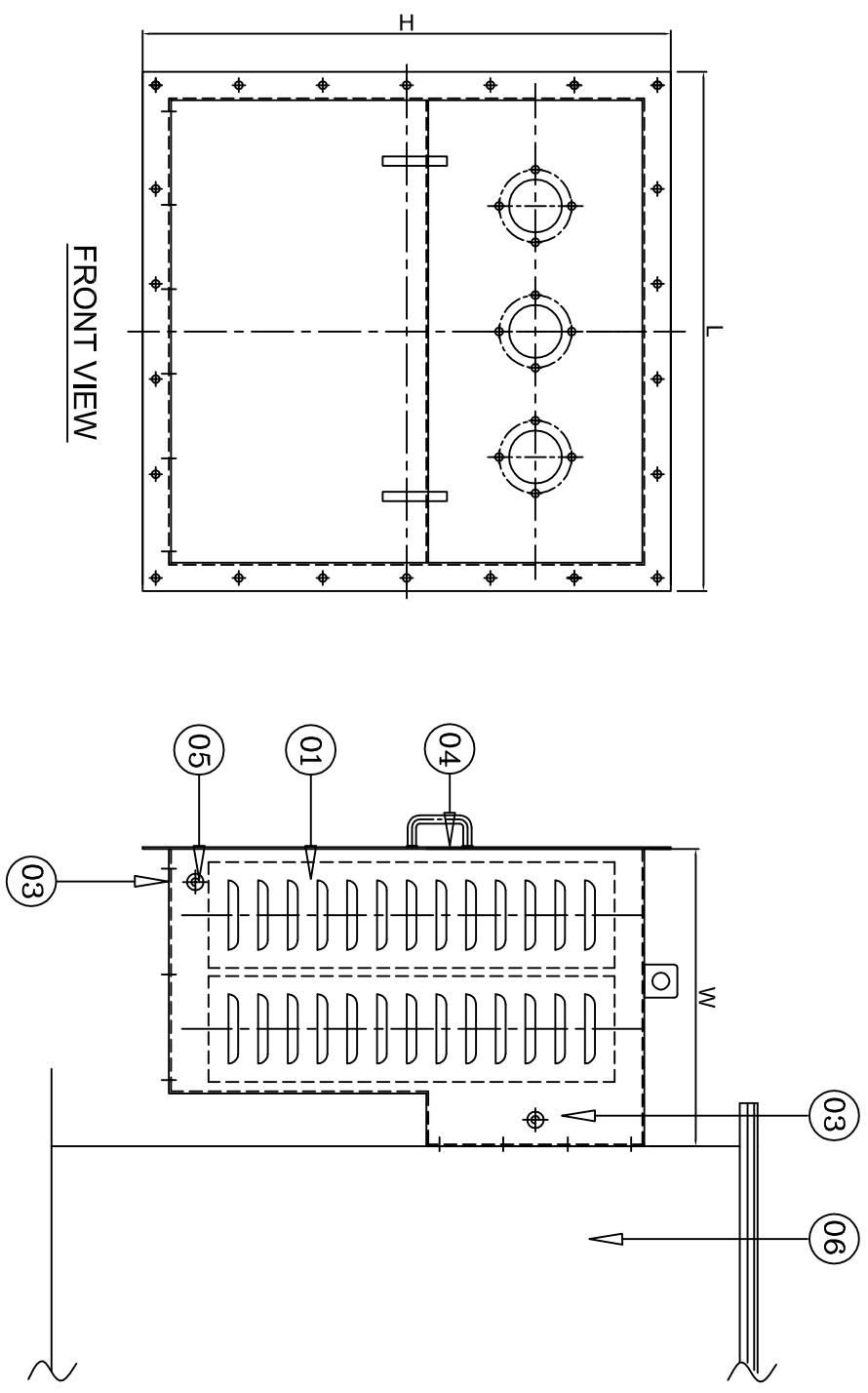

FRONT VIEW

SIDE VIEW

THESE ARE INDICATIVE DRAWINGS.

1	6	ENCLOSURE	MS.
2	5	EARTHING BOSS	MS.
1	4	FRONT COVER	MS
1	3	DETACHABLE GIAND PLATE	MS
3	2	HV BUSHING	PORCELAIN
1	1	CABLE BOX SHELL	MS.
QTY	IT. NO.	DESCRIPTION	MATL.

BILL OF MATERIAL

ALL DIMS. ARE IN M.M., EXCEPT STATED.		SCALE	ORDER NO.
TITLE :-		N/S	-
CUSTOMER		DRN. BY	NAME
MARASHTRA STATE ELECTRICAL DIST. CO. LTD		CHD. BY	SIGN.
SCHEME		APPD. BY	DATE
PATH		DRG. NO. :-	SHEET 1 OF 1
			REV.
			R-0

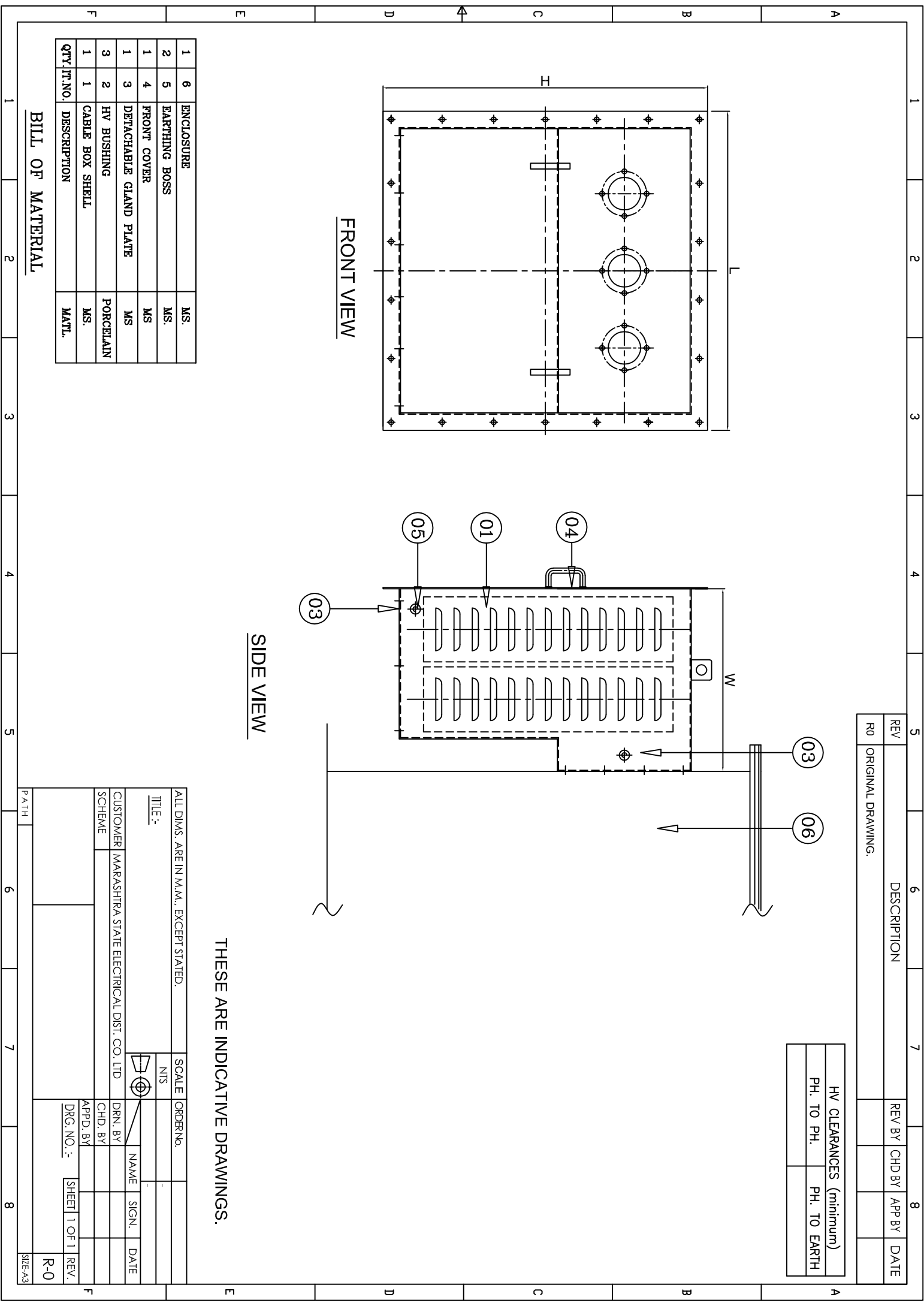

5	6	7	8
REV	DESCRIPTION	REV BY	CHD BY
R0	ORIGINAL DRAWING.		
APP BY	DATE		

LV CLEARANCES (minimum)	
PH. TO PH.	PH. TO EARTH

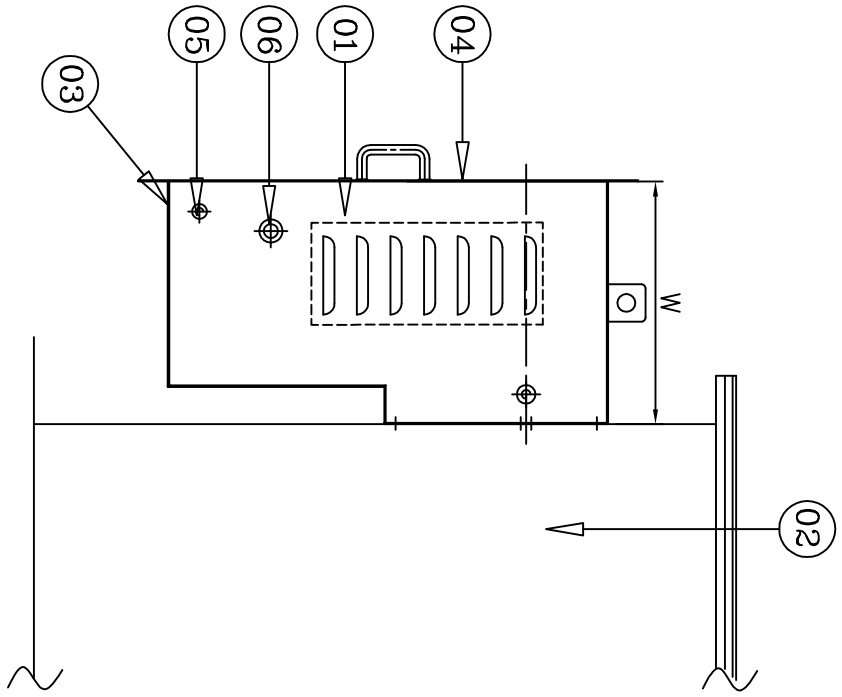
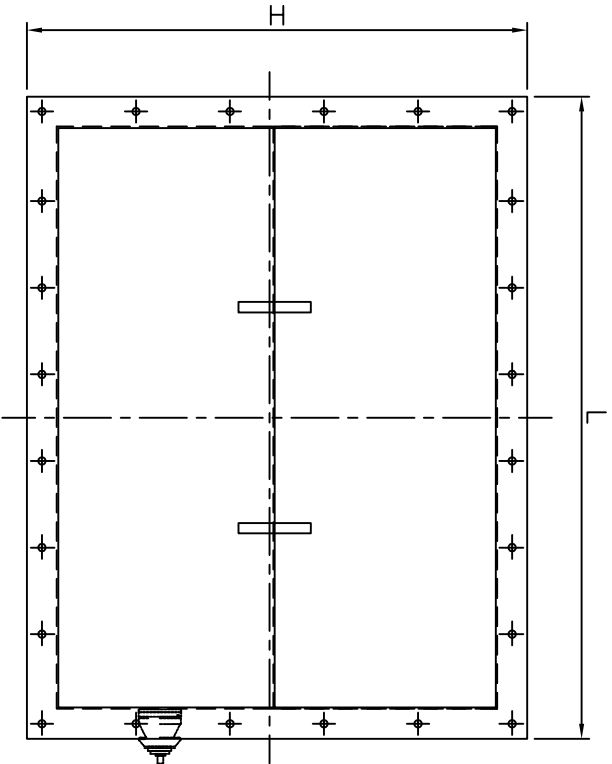

THESE ARE INDICATIVE DRAWINGS.

QTY.	IT. NO.	DESCRIPTION	MATL.
1	1	CABLE BOX SHELL	MS.
1	2	ENCLOSURE	MS.
1	3	DETACHABLE GIAND PLATE	MS
1	4	FRONT COVER	MS
2	5	EARTHING BOSS	MS.
1	6	ADDITIONAL NEUTRAL BUSHING	PORCELAIN

BILL OF MATERIAL

ALL DIMS. ARE IN M.M., EXCEPT STATED.		SCALE	WORK ORDER NO.
TITLE :-		N/S	-
CUSTOMER	MARASHTRA STATE ELECTRICAL DIST. CO. LTD	DRN. BY	NAME
SCHEME		CHD. BY	SIGN.
		APPD. BY	DATE
DRG. NO. :-		SHEET 1 OF 1	REV.
PATH			R-0