

MATERIAL SPECIFICATIONS CELL

TECHNICAL SPECIFICATION

OF

LT AC SINGLE PHASE 10 - 60 AMPS PREPAID
STATIC ENERGY METER AS PER IS: 16444-2015
WITH COMMUNICATION MODULE

TABLE OF CONTENTS

1.00	SCOPE	3
2.00	SERVICE CONDITIONS	3
3.00	APPLICABLE STANDARDS	4
4.00	SYSTEM ARCHITECTURE	5
5.00	GENERAL TECHNICAL REQUIREMENTS	7
6.00	CONSTRUCTION.....	8
7.00	COMMUNICATION CONNECTIVITY SCOPE	18
8.00	TOD TIMING.....	18
9.00	MAXIMUM DEMAND INTEGRETION PERIOD	19
10.00	MD RESET	19
11.00	WEB BASED PREPAID APPLICATION.....	19
12.00	PREPAID ENGINE	24
13.00	PREPAID AND CONNECT/DISCONNECT FEATURES	25
14.00	TAMPER & FRAUD MONITORING FEATURES:.....	25
15.00	DISPLAY OF MEASURED VALUES	30
16.00	BILLING DATA,BILLING HISTORY, LOAD SURVEY & TAMPER DATA	34
17.00	DEMONSTRATION	37
18.00	CONNECTION DIAGRAM AND TERMINAL MARKINGS.....	37
19.00	ACTIVITIES WITHIN SCOPE OF SOLUTION PROVIDER.....	37
20.00	MARKING OF METER	38
21.00	TESTS.....	39
22.00	GUARANTEED TECHNICAL PARTICULARS	42
23.00	TENDER SAMPLE	42
24.00	PRE DESPATCH INSPECTIONS	43
25.00	INSPECTION AFTER RECEIPT AT STORES (RANDOM SAMPLE TESTING)	43
26.00	TRAINING	44
27.00	GUARANTEE	44
28.00	PACKING.....	44
29.00	QUALITY CONTROL.....	45
30.00	MINIMUM TESTING FACILITIES	45
31.00	MANUFACTURING ACTIVITIES	46
32.00	QUALITY ASSURANCE PLAN	49
33.00	COMPONENT SPECIFICATION	49
34.00	SCHEDULES.....	49
	ANNEXURE - I	52
	ANNEXURE - II	54
	SCHEDULE 'A'	58

1.00 SCOPE

This specification covers the design, engineering, manufacture, assembly, stage testing, inspection and testing before dispatch and delivery at designated stores of ISI marked LT AC 10 - 60 Amps AMR compatible Prepaid Static LCD Single Phase Energy Meter of class 1.0 accuracy with communication module conforming to IS: 16444 / 2015 of the latest version suitable measurement of Energy (kWh) and Demand (kWMD) in Single Phase, Two wire system of LT single phase residential, LT single phase commercial & LT single phase temporary consumers.

The meter shall conform in all respects to high standards of engineering, design and workmanship and shall be capable of performing in continuous commercial operation, in a manner acceptable to purchaser, who will interpret the meaning of drawings and specification and shall have the power to reject any work or material which, in his judgment is not in accordance therewith. The offered material shall be complete with all components necessary for their effective and trouble free operation. Such components shall be deemed to be within the scope of Bidder's supply irrespective of whether those are specifically brought out in these specifications and / or the commercial order or not.

2.00 SERVICE CONDITIONS

The meter to be supplied against this specification shall be suitable for satisfactory continuous operation under the following tropical conditions.

a) Maximum ambient temperature	55 ⁰ C
b) Maximum ambient temperature in shade	45 ⁰ C
c) Minimum temperature of air in shade	35 ⁰ C
d) Maximum daily average temperature	40 ⁰ C
e) Maximum yearly weighted average temperature	32 ⁰ C
f) Relative Humidity	10 to 95 %
g) Maximum Annual rainfall	1450 mm
h) Maximum wind pressure	150 kg/m ²
i) Maximum altitude above mean sea level	1000 meter
j) Isoceraunic level	50 days/year
k) Seismic level (Horizontal acceleration)	0.3 g

- 1) Climate: Moderately hot and humid tropical climate conducive to rust and fungus growth.

3.00 APPLICABLE STANDARDS

While drawing these specifications, reference has been made to following Indian and International Standard specification. In case certain details are not covered in these specifications, the relevant Indian and International Standard shall be applicable.

IS: 16444 / 2015 of the latest version including CBIP Tech – report - 325 amended up to date, CEA regulations and MERC guidelines with latest amendments.

IS: 15707 / 2006: Specification for Testing, evaluation, installation & maintenance of AC Electricity Meters-Code of Practice.

IEC 62052-11 (2003) : Electricity Requirements (AC) General Requirements, Tests and Test conditions for A.C. Static Watt hour meter for active energy Class 1.0 and 2.0.

IEC 62053-21 (2003): A.C. Static Watt hour meter for active energy Class 1.and 2.0.

CEA Regulation on installation and operation of meters dtd: 17/03/2006 with all latest amendments

The equipment meeting with the requirements of other authoritative standards, which ensures equal or better quality than the standard mentioned above, also shall be considered.

For conflict related with other parts of the specification, the order of priority shall be – (i) this technical specification, (ii) IS: 16444 / 2015 of the latest version.

NOTE: Unless otherwise specified elsewhere in this specification the meters shall conform to the latest version available of the standard as specified above. If above IS/IEC reports are amended, reference has to be made to Amended IS/IEC/Report up to the date of tenderization.

4.00 SYSTEM ARCHITECTURE

4.01 24x7 Online System

Prepaid metering system should be **24x7 online system**, where prepaid meter should be capable to communicate with prepaid server. Also meter should push billing parameters, tamper information to prepaid server at regular intervals and meter should be capable to connect/disconnect the load according to commands received from prepaid server.

TECHNICAL SPECIFICATION OF SINGLE PHASE 10-60 AMPS PREPAID METER

The prepaid metering system with communication module shall comprise of following components.

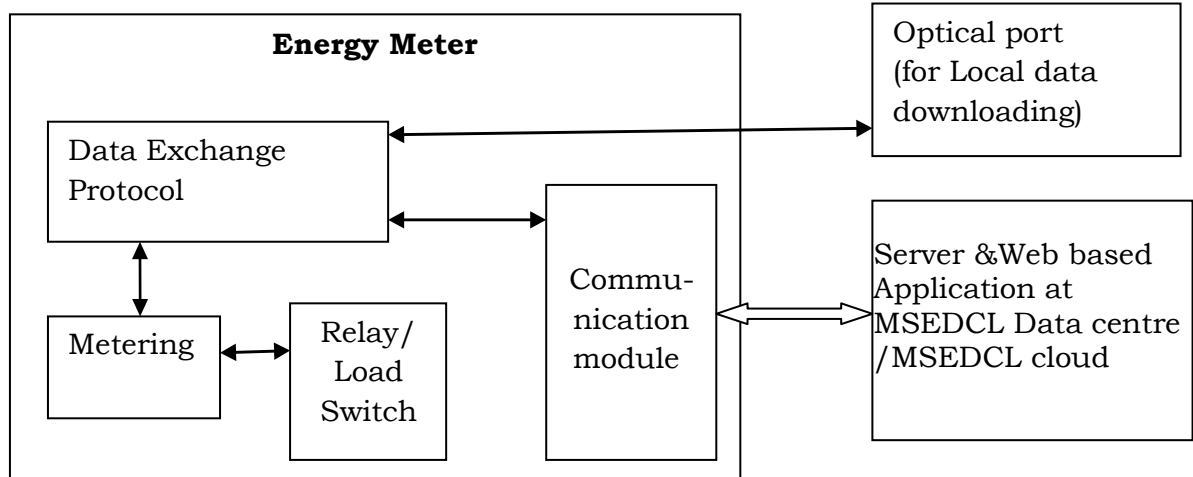

4.02 Metering :

Metering and metrology requirement shall be according to IS 16444:2015 (A.C. Static direct connected watt-hour smart meters Class 1 and 2. - specifications).

4.03 Relay/Load Switch:

The meter shall be provided with switching elements, integral with the meter enclosure, to control the flow of electricity to the load at the instance of connect/disconnect commands as per functional needs of the system.

4.04 Communication module:

The meter shall be provided with in-built/plug-in type communication module (6LoWPAN LPRF or GSM/GPRS or NB-IOT or LoRa or PLC or any other communication technology proposed by the bidder) capable of establishing wireless communication with external entities such as Prepaid server, Head End System, DCU etc. Two way communication with external entities should be possible. Communication module and technology should be proposed by the bidder.

4.05 Optical port:

The meter should have optical port for wired data download locally. The optical port complying with hardware specifications detailed in IEC – 62056 – 21. The baud rate while downloading data through optical port should be 9600. It should be possible to download the data through optical port in case of power failure.

4.06 Prepaid Engine & Web based prepaid application:

Remote server having prepaid engine and web base prepaid application with all the vending station functionalities will be hosted on remote server at MSEDCL data center/MSEDCL cloud. The bidder is responsible for uptime of remote server.

5.00 GENERAL TECHNICAL REQUIREMENTS

The equipment shall conform to the following specific parameters.

5.01 The meter to be supplied shall bear ISI mark before commencement of supply.

5.02 Class of Accuracy:

The class of accuracy of the energy meter shall be 1.0. The accuracy shall not drift with time.

5.03 Current & Voltage Rating:

The current rating shall be 10 - 60 Amps. The rated basic current (I_b) shall be 10 Amps.

The maximum continuous current (I_{max}) shall be 600% of rated basic current i.e. 60 Amps. Moreover the 10 - 60 Amps meter shall work accurately upto 120% of I_{max}, i.e. 72 Amps.

The Voltage Rating shall be 240 volts. The voltage range shall be (-) 40 % to (+) 20% of rated voltage, i.e. 144 Volts to 288 Volts.

5.04 Temperature:

The reference temperature for performance shall be 27° C. The mean temperature co-efficient shall not exceed 0.07%. Temperature rise shall be as per IS: 15884 / 2010 of the latest version.

5.05 Power Factor:

The meter shall work for Zero to unity PF (All lag or lead)

5.06 Power Consumption.

5.06.01 Voltage Circuit:

The active & apparent power consumption in voltage circuit including power supply of meter at reference voltage, reference temperature & frequency shall not exceed 5 Watts & 15 VA during the idle mode communication module. The additional power requirement during data transmission shall not exceed 7W per communication module.

5.06.02 Current Circuit:

The apparent power taken by current circuit at maximum current,

reference frequency & reference temperature shall not exceed 11.5 VA.

5.07 Starting Current.

Meter shall start registering the energy at 0.2 % of basic current (I_b).

5.08 Frequency.

The rated frequency shall be 50 Hz with a tolerance of $\pm 5\%$.

6.00 CONSTRUCTION

6.01 GENERAL MECHANICAL REQUIREMENT

The prepaid meter shall be designed and constructed in such a way as to avoid introducing any danger in normal use and under normal conditions, so as to ensure especially:

- a) personal safety against electric shock;
- b) personal safety against effects of excessive temperature;
- c) protection against spread of fire;
- d) protection against penetration of solid objects, dust and water in the meter.

6.02 Meters are required for measurement of Active Energy and shall conform to the latest edition of IS: 16444 / 2015(Alternating Current Static direct connected watt-hour smart meters Class 1 and 2 – Specification.

6.03 The meter shall measure the electrical energy consumed.

6.04 All parts, which are subject to corrosion under normal working conditions, shall be protected effectively against corrosion by suitable method to achieve durable results. Any protective coating shall not be liable to damage by ordinary handling nor damage due to exposure to air, under normal working conditions. The electrical connections shall be such as to prevent any opening of the circuit under normal conditions of use as specified in the standard, including any overload conditions specified in the standard. The construction of the meter shall be such as to minimize the risks of short-circuiting of the insulation between live parts and accessible conducting parts due to accidental loosening or unscrewing of the wiring, screws, etc. The meter shall not produce appreciable noise in use.

6.05 The meter shall be projection type, dust and moisture proof. The meter base & cover shall be made out of unbreakable, high grade, fire resistant Polycarbonate material so as to give it tough and non-breakable qualities. The meter base & cover shall be transparent. The meter body shall be type tested for IP51 degree of protection as per IS:

12063 against ingress of dust, moisture & vermin, but without suction in the meter.

6.06 METER CASE

The base and cover shall be ultra-sonically welded (continuous welding) so that once the meter is manufactured and tested at factory, it shall not be possible to open the cover at site except the terminal cover and any non-permanent deformation cannot prevent the satisfactory operation of the meter. The components shall be reliably fastened and secured against loosening. The manufacturer shall put at least one seal on meter body before dispatch. The thickness of material for meter body shall be 2 mm minimum. The holding on and sealing screws shall be held captive in the meter cover. The meter shall have a durable and substantially continuous enclosure made wholly of insulating material, including the terminal cover which envelopes all metal parts.

6.07 TERMINALS & TERMINAL BLOCK

- 6.07.01 The terminal block shall be made from high quality non-hygroscopic, fire retardant, reinforced polycarbonate (non-Bakelite) which shall form an extension of the meter case.
- 6.07.02 The material of which the terminal block is made shall be capable of passing the tests given in IS 13360 (Part 6/Sec 17) for a temperature of 135°C and a pressure of 1.8 MPa (Method A). The holes in the insulating material which form an extension of the terminal holes shall be of sufficient size to also accommodate the insulation of the conductors.
- 6.07.03 The conductors where terminated to the terminals shall ensure adequate and durable contact such that there is no risk of loosening or undue heating. Screw connections transmitting contact force and screw fixings which may be loosened and tightened several times during the life of the meter shall screw into a metal nut. All parts of each terminal shall be such that the risk of corrosion resulting from contact with any other metal part is minimized.
- 6.07.04 Electrical connections shall be so designed that contact pressure is not transmitted through insulating material.
- 6.07.05 Two screws shall be provided in each current terminal for effectively clamping the external leads or thimbles. Each clamping screw shall engage a minimum of three threads in the terminal. The ends of screws shall be such as not to pierce and cut the conductors used.
- 6.07.06 The minimum internal diameter of terminal hole shall be as per IS.

TECHNICAL SPECIFICATION OF SINGLE PHASE 10-60 AMPS PREPAID METER

- 6.07.07 The terminals, the conductor fixing screws or the external or internal conductors shall not be liable to come into contact with terminal covers.
- 6.07.08 The termination arrangement shall be extended type as per as per clause number 4.2.5 of IS: 15884 / 2010 of the latest version irrespective of rear connections.
- 6.07.09 The manufacturer shall ensure that the supporting webs between two terminals of the terminal block shall be sufficiently high to ensure that two neighboring terminals do not get bridged by dust and there shall not be any possibility of flash over between adjacent terminals of the terminal block.
- 6.07.10 The construction of the meter shall be suitable for its purpose in all respects and shall be given reasonable assurance of continuous performance in all mechanical, electrical and magnetic adjustments. The construction shall be such that the meter is not prone to produce audible noise in use. The meter cover & terminal cover shall be of injection molded in transparent UV stabilized polycarbonate in a natural transparent colour.

Polycarbonate material of only following manufacturers shall only be used:

- | | |
|------------------|---|
| a) GE PLASTICS | LEXAN 943A FOR COVER AND TERMINAL COVER |
| | LEXAN 503R FOR BASE |
| b) BAYER | GRADE CORRESPONDING TO ABOVE |
| c) DOW CHEMICALS | -----do ----- |
| d) MITSUBISHI | -----do ----- |
| e) TEJIN | -----do ----- |

The meter base shall be manufactured from high quality industrial grade material viz. Polycarbonate with 10 % glass filled which shall meet following properties to ensure higher reliability and long life of the meter case.

- 6.08 A sticker label containing warning notice in Marathi language which is to be stick up on meters front cover or printed on meter name plate with easily readable font size not less than 10 in red colour, which reads as “सावधान ! मीटरला फेरफार करण्याचा प्रयत्न केल्यास अधिकतम वेगाने वीज नोंदणी होणार.”

6.09 TERMINAL COVER

- 6.09.01 The termination arrangement shall be provided with an extended

transparent terminal cover as per clause number 4.2.5 of IS: 15884 / 2010 of the latest version irrespective of rear connections.

- 6.09.02 The terminal cover of a meter shall be sealable independently of the meter cover to prevent unauthorized tampering.
- 6.09.03 The terminal cover shall enclose the actual terminals, the conductor fixing screws and unless otherwise specified, a suitable length of external conductors and their insulation.
- 6.09.04 The fixing screws used on the terminal cover for fixing and sealing in terminal cover shall be held captive in the terminal cover.
- 6.09.05 When the meter is mounted, no access to the terminals shall be possible without breaking seals(s) of the terminal cover.
- 6.09.06 The terminal cover shall be made out of unbreakable, high grade, fire resistant Polycarbonate material so as to give it tough and non-breakable qualities. The terminal cover shall be transparent.

6.10 RATING OF TERMINALS

The terminals shall be of suitable rating and shall be capable of carrying 120% of I_{max} and made of electro-plated (or tinned) brass and shall be of replaceable type.

- 6.11 The provision shall be made on the meter for at least two seals to be put by utility user.
- 6.12 All insulating materials used in the construction of the meter shall be substantially non-hygroscopic, non ageing and of tested quality.
- 6.13 A push button shall be provided for high resolution reading of display with three decimal digits as brought out elsewhere in this specification (optional).

6.14 RESISTANCE TO HEAT AND FIRE

The terminal block, the terminal cover, the insulating material retaining the main contacts in position and the meter case shall ensure reasonable safety against the spread of fire. They shall not be ignited by thermal overload of live parts in contact with them.

The material of the terminal block shall not deflect under heating. To comply therewith, they must fulfill the tests as specified in 5.2.4 of IS: 15884 / 2010 of the latest version.

A push button shall be provided for scrolling the parameters in Alternate Display (On Demand) mode as well as for crediting emergency credit units in the meter as brought out elsewhere in the specification.

6.15 REAL TIME INTERNAL CLOCK (RTC)

The real time quartz clock shall be used in the meter for maintaining time (IST) and calendar. The RTC shall be non - rechargeable and shall be pre-programmed for 30 Years Day / date without any necessity for correction. The maximum drift shall not exceed +/- 300 seconds per year. The calendar and the clock shall be correctly set to Indian Standard Time. The RTC shall have long life (minimum 10 Years) with Non rechargeable battery.

6.16 Meter memory shall have the following details.

- Transaction history data with date & time
- All the events history with time based and category based information,
- Monthly history and consumption data of the energy consumed for the last 12 months,
- All the limiting parameters shall also be available in meter reading.

6.17 RETENTION TIME OF THE NON-VOLATILE MEMORY

For long outages, the payment meter shall be designed such that any data necessary for correct operation shall be retained for a minimum period of 10 years without an electrical supply being applied to the meter.

6.18 OUTPUT DEVICE

6.18.01 The meter shall have a test output device preferably with flashing red LED accessible from front and capable of being monitored with suitable testing equipment.

6.18.02 Output devices generally may not produce homogeneous pulse sequences. Therefore, the manufacturer shall state the necessary number of pulses to ensure that measurement uncertainty factor due to repeatability of meter is less than 1/10 of the error limits specified at different test points and consistent with desired resolution.

6.18.03 The resolution of the test output in the form of pulses of high resolution register, whether accessible on the meter through external display, shall be sufficient to conduct satisfactorily accuracy test at lowest test point defined in particular requirements in less than 5 min and starting current test in less than 10 min.

6.19 The meter shall be capable to withstand phase to phase voltage (440V) if applied between phase to neutral continuously.

TECHNICAL SPECIFICATION OF SINGLE PHASE 10-60 AMPS PREPAID METER

- 6.20 Power supply unit in the meter shall be transformer less to avoid magnetic influence.
- 6.21 Meter shall be tamper proof. No tampering shall be possible through Optical port.
- 6.22 Display parameters in the meter shall not be accessible for reprogramming at site through any kind of communication.
- 6.23 The measurement by meter shall not get influenced by injection of High frequency AC Voltage / chopped signal / DC signal and harmonics on the terminals of the meter.
- 6.24 The meter shall record and display total energy including Harmonic energy.
- 6.25 The meter shall be provided with LED/LCD indicators for communication in progress. Two separate LED/LCD indicators should be provided for data transmission (TxD) mode and data receiving (Rx) mode.

6.26 SELF DIAGNOSTIC FEATURES

- 6.30.01 The meter shall be capable of performing complete self diagnostic check to monitor the circuits for any malfunctioning to ensure integrity of data memory location all the time.
- 6.30.02 The meter shall display unsatisfactory functioning / nonfunctioning / malfunctioning of Real Time Clock, battery.
- 6.30.03 All display segments: "LCD Test" display shall be provided for this purpose.

6.27 WIRE / CABLE LESS DESIGN

The meter shall be wireless to avoid improper soldering & loose connection / contact.

- 6.28 The meter shall remain immune for the test of electromagnetic HF/RF defined under the test no. 4.0 mentioned in table 20 for EMI/EMC of IS 13779:1999 amended up to date. The meter shall remain immune for any higher signals than the present standards and MSEDCL technical specifications as indicated above.
- 6.29 The communication of energy meters shall not be affected considering the above feature state in the clause 6.28
- 6.30 The watch dog provided shall invariably protect the hanging of microprocessor during such type of tampering devices.
- 6.31 The fully tested double layered glass epoxy shall be used. The latest technology such as hybrid microcircuit or application specific

integrating circuit (ASIC) shall be used to ensure reliable performance. The mounting of components on the PCB shall be SMT (Surface Mounted Technology) Type. The electronic components used in the meter shall be of high quality from world renowned manufacturers and there shall be no drift in accuracy of the meter for at least up to 5 ½ years.

The meter PCB shall be wireless to avoid improper soldering & loose connection / contact. The PCB material shall be Glass Epoxy, fire resistance grade FR4, with minimum thickness 1.6 mm. It should be framed by A class vendor.

6.32 PCB used in meter shall be made by Surface Mounting Technology.

6.33 The meter shall be capable of being read through communication module and optical port.

6.34 LATCHING RELAY (LOAD SWITCH)

6.39.01 Meter shall have two latching relays for phase and neutral to protect the common tamper of phase and neutral interchanged, load through local earth, single wire tamper as well as to disconnect the full load.

6.39.02 The latching relay shall be bi-stable type latching switch designed and manufactured in accordance with international standard of IEC and DIN EN 61810 part 1 / VDE 0435 part 201 as well as they shall meet the overload and short circuit requirement of IEC, DIN EN 61036 / 61037 & ANSI C12. The Latching relay shall conform to the load switching capabilities as per relevant IS. The latching relay shall be with trip-free design as given in IS.

6.39.03 Precautionary measures shall be taken to protect the latching relay from adverse effects resulting from the ingress or vermin into the payment meter.

6.39.04 The latching relay shall be designed and rated to make and break at V_{ref} , I_{max} with a linear resistive load and at V_{ref} , I_b , 0.4 inductive power factor for 3,000 operations.

6.39.05 Latching relay should connect and disconnect supply according to signal received from remote server having prepaid engine.

6.39.06 Once the load is interrupted by disconnect command from prepaid engine, the latching relay shall only be operable to restore the load after a further appropriate connect command received from prepaid engine or through optical port.

6.35 The meter shall be able to disconnect the load in case of exceeding the current limit ($105\% I_{max}$) after 1 minute on stabilizing the current.

6.36 COMMUNICATION CAPABILITY

The communication capability of the meter shall be based on in built/plug-in type communication module (6LoWPAN LPRF or GSM/GPRS or NB-IOT or LoRa or PLC or any other communication technology proposed by the bidder) and optical port complying with hardware specifications detailed in IEC – 62056 – 21

6.41.01 COMMUNICATION MODULE

Functionalities of communication module are as below:

1. Establish 24*7 wireless communication with external entities such as Prepaid Server, Head End System, DCU etc. The communication should be bi-directional i.e. from meter to external entity and from external entity to meter.
2. Communication module should support both push and pull features.
3. Communication module should push continuously instantaneous parameters (as per clause No. 15.03) to prepaid engine running on prepaid server located at MSEDCL data centre/MSEDCL cloud. The interval for pushing instantaneous parameters should be configurable.
4. Events should be pushed to prepaid engine by communication module immediately after occurrence and restoration.
5. It is possible to schedule the communication module from prepaid server to fetch any data on demand.
6. Communication module should transfer the connect/disconnect signals received from prepaid server to meter.

6.41.02 The choice of communication module and technology should be based on technical feasibility best suited for given geographical area.

6.41.03 The communication between meter and prepaid server should be secure. It should not be possible to alter the contents during communication.

6.41.04 The communication technologies to be implemented should follow relevant national and international standards as applicable. Any suitable standard from International Telecommunication Union (ITU)/ International Electrotechnical Commission (IEC)/ Institute of Electrical and Electronics Engineers (IEEE) /European Standardization Organization (CEN/CENELEC/ETSI) may be considered. The bidder shall submit necessary compliance certificate from official test houses or from reputed alliances along with offer.

6.41.05 The RF technology if proposed for communication module shall be in

the frequency bands notified by Government of India.

- 6.41.06 Cellular technologies if proposed should be supporting 2G, 3G, 4G or an optical fiber communications network complying to IPv6. The necessary service level agreements (SLA) should be done by bidder with service providers.
- 6.41.07 Wireless technologies proposed need to comply with Indian statutory bodies that govern communication related aspects such as WPC (Wireless Planning Co-ordination wing).
- 6.41.08 Equipment Type Approval (ETA) is to be obtained for communication modules as per Department of Telecom, Govt. of India requirements. The bidder shall submit ETA approval issued by WPC along with offer.
- 6.41.09 Radio emission characteristics for the chosen band shall comply with latest NFAP (National Frequency Allocation Plan) and the G.S.R (General Statutory Rules) notifications from Department of Telecom, Government of India

6.41.10 GPRS COMMUNICATION MODULE

- i. The meter should have 4G communication module. The 4G module should have facility to fall back to 2G and 3G networks, where 4G network is not available.
- ii. The module should support both Data and SMS transmission. It should have GSM, GPRS/EDGE and 4G LTE features.
- iii. There should be provision to insert SIM card externally. The SIM slot should have adequate sealing arrangements.
- iv. SIMs will be provided by the utility. Also the SIM charges will be borne by the utility.
- v. The functionalities of 4G module should be as below.
 - a. The module should be capable of establishing wireless communication with external entities such as Server, Head End System etc. The communication should be bi-directional i.e. from meter to external entity and from external entity to meter.
 - b. The module should support both push and pull features.
 - c. The module should push continuously meter data to prepaid engine running on server located at MSEDCL data center/MSEDCL cloud. The interval for pushing meter data should be configurable from Head End System. Default interval for pushing data is 15 minutes and also it should be configurable.

TECHNICAL SPECIFICATION OF SINGLE PHASE 10-60 AMPS PREPAID METER

- d. Events should be pushed to prepaid engine by the module immediately after occurrence and restoration.
- e. It should be possible to schedule the module from server to fetch any data on demand.
- f. The module should transfer the connect/disconnect signals received from server to meter.
- g. The module should auto-configure itself, after insertion of SIM card.
- h. The module should support remote firmware upgrade as well as remote configuration from server.
- vi. The meter should have optical port for wired data downloading. The baud rate while downloading data through optical port should be 9600. It should be possible to download the data through optical port in case of power failure. The meter should support connect/disconnect commands through optical port.

The communication between meter and sever should be secure. It should not be possible to alter the contents during communication.

6.41.11 6LoWPAN LPRF COMMUNICATION MODULE

1. The meter should have 6LoWPAN LPRF communication module. The smart meter data using RF mesh shall be collected by Data Concentrator Units (DCUs) and transported to HES through WAN.
2. The 6LoWPAN based Internal Low Power Radio Frequency (LPRF) module shall be based on 6LoWPAN networking on sub-1 GHz (865-867 MHz).
3. The meter should have optical port for wired data downloading. The baud rate while downloading data through optical port should be 9600. It should be possible to download the data through optical port in case of power failure. The meter should support connect/disconnect commands through optical port.
4. The communication between meter and sever should be secure. It should not be possible to alter the contents during communication

6.41.12 DATA CONCENTRATOR UNIT (DCU)

- i. The Data Concentrator Unit is a gateway for communication of data between the Smart Meters and the HES. The Data Concentrator Unit receives information from the Smart Meter on a scheduled / need basis and stores the data, which can be accessed by HES for onward transfer to Server

TECHNICAL SPECIFICATION OF SINGLE PHASE 10-60 AMPS PREPAID METER

- ii. The DCU provides the central link between Smart Meters and HES, enabling continuous/periodic meter read and control. DCU shall exchange data from smart meters on RF and with HES on WAN.
- iii. Enclosure/box of DCU shall be minimum IP55 or better compliant. A suitable mounting arrangement required for DCU installation shall also be provided.
- iv. A suitable and optimum power supply shall be provided keeping in view that even in case of outage in one or two phases, DCU can be powered. DCU should be capable of withstanding surges & voltage spikes of 6KV as per IEC 61000-4-5 standards. Power supply shall be terminated on suitable sized MCB to facilitate isolation during on-site maintenance.
- v. DCU shall have battery with backup for 1 hour for normal meter reading, to push tamper event, carry out on demand reading and the network health status / connectivity continuity & check. DCU should have the suitable feature to send power outage and restoration message to the HES. The battery shall have a guaranteed life of 10 years.
- vi. DCU shall have built in Real Time Clock (RTC) with separate battery backup. The battery shall have a guaranteed life of 10 years. It shall have self diagnostic feature for RTC, memory, battery, communication module, etc. Alternatively, Software driven RTC may also be used as per agreement between supplier and utility.

6.41.13 DCU shall have following configuration functionalities:

- i. It shall be able to configure the communication with underlying nodes/meters.
- ii. It shall pull data from the field devices and push the data at configured intervals to the HES. It should also support the HES in pulling data from the field devices/meters. The data acquisition (Push/Pull) frequency shall be programmable. DCU shall be capable to prioritize control commands.
- iii. DCU shall ensure a secure communication to HES and shall have internal memory for storing interval data for at least 5 days.
- iv. DCU shall support on demand read and ping of individual/group of meters.
- v. DCU shall push events like tamper, power off etc. to HES immediately on occurrence/receipt from field devices/meters.

TECHNICAL SPECIFICATION OF SINGLE PHASE 10-60 AMPS PREPAID METER

- vi. The equipment shall be weatherproof, dustproof and constructed for outdoor installation on poles (minimum rating: IP-55). A suitable mounting provision shall be made for the equipment.
- vii. Enclosure: Provision for security sealing shall be provided and in case the gasket of the cover is used for protection against moisture, dust and insects, the gasket shall be made of weather and aging resistant material.
- viii. The list of standards followed in all the devices/equipment used in communication network shall be furnished

6.41.14 DCU Communication:

- 1. The communication architecture shall be any, as defined under IS 16444.
- 2. The DCU shall ensure the appropriate backhaul for secure transfer of data to HES. In case of GPRS/3G/4G backhaul, it shall support SIM card from any service provider. It shall have Wide Area Network (WAN) connectivity to the HES through suitable means.
- 3. DCU shall be able to communicate with meters RF mesh (license free band)
- 4. DCU shall periodically monitor meter reads/downstream commands and shall retry and reconnect in case of failed events/reads.
- 5. It shall push events like tamper, power off etc. to HES immediately on occurrence/receipt from field devices/meters. DCU shall be able to acquire and send data to HES for full capacity (as per designed for no. of meters/field devices) to ensure the performance level. Full capacity of DCU is required to be indicated in the offer.
- 6. After Power Interruption, on restoration of power supply, DCU shall establish communication with underlying devices as well as upstream application automatically.
- 7. DCU shall be able to communicate with the nearest meters depending on topographical features. For further communication among the meters, distance of the other meters with the DCU shall not be a constraint as communication of the nearest meters shall be established with other meters through appropriate mesh formation / other formation.
- 8. Remote Firmware Upgrade: The DCU shall support remote firmware upgrades as well as remote configuration from the control center. Configuration of programmable parameters of smart meters shall be done through HES
- 9. All meters falling under one DCU shall be commissioned and checked for proper communication in presence of utility in-charge.
- 10. DCU shall keep the records of minimum of the following events:

- No of packet failures
- Retry attempts
- Missed periodic readings
- Failure to connect
- Tamper events

6.41.15 Testing of the DCU:

- a. DCU shall be tested for the following:
- b. Radio interference measurement (CIS PR 22)
- c. Surge test (IEC 610004-5)
- d. Fast transient burst test (IEC 61000-4-4)
- e. Test of immunity to electrostatic discharges (IEC 61000-4-2)
- f. Test of immunity to electromagnetic HF field (IEC 61000-4-3)
- g. Resistance to heat and fire
- h. The bidder shall provide IP-55 compliance test certificate for DCU.

6.41.16 The bidder may propose any other communication technology other than communication technologies mentioned above. Bidder has to provide complete solution for meters based on such technology

7.00 Metering Protocol:

As per IS: 15959 / 2011 (Part-I) and IS:15959/2016 (Part-II) with latest amendments

8.00 TOD TIMING

There shall be provision for at least 6 (Six) TOD time zones for energy and demand. The number and timings of these TOD time Zones shall be programmable. At present the time zones shall be programmed as below.

Zone A (TZ1): 00=00 Hrs. to 06=00 Hrs. and 22=00 Hrs. to 24=00 Hrs

Zone B (TZ2): 06=00 Hrs. to 09=00 Hrs. and 12=00 Hrs. to 18=00 Hrs

Zone C (TZ3): 09=00 Hrs. to 12=00 Hrs.

Zone D (TZ4): 18=00 Hrs. to 22=00 Hrs.

9.00 MAXIMUM DEMAND INTEGRATION PERIOD

The maximum demand integration period shall be set at 30 minute as per requirement.

10.0 MD RESET

It shall be possible to reset MD by the following options:

Auto reset at 24:00 hrs at the end of each billing cycle: Automatic reset at the end of certain predefined period (say, end of the month). This option shall be programmable through prepaid server for the actual date required. No push button shall be provided for MD reset.

11.0 WEB BASED PREPAID APPLICATION

11.01 The bidder shall develop web based prepaid application which will be deployed on server at MSEDCL data centre/MSEDCL cloud.

11.02 Web based prepaid application should be developed in any platform such as Java, .Net etc.

11.03 This application should be scalable and performance of application shall not decrease with increasing number of users.

11.04 Web based prepaid application should be integrated with MSEDCL New Connection (NC) & legacy billing system. The updation made in prepaid consumer data at NC system and billing system should be reflected immediately into the prepaid application and vice-versa. Following provisions should be done.

- Change in connection type of consumer from prepaid to postpaid and vice-versa. If connection type is changed from postpaid to prepaid, there shall be provision to assign prepaid meter for such consumers.

-Provision for permanent disconnection of prepaid consumer.

11.05 Web based prepaid application should support following functionalities.

1) Login: There should provision to login into prepaid application. Separate login should be provided for consumer and MSEDCL field offices. Also there should be login with administrator role.

2) Configuration of consumers: After installation of prepaid meters, there should provision to configure the consumer and meter details into the prepaid application. This configuration is to be done through integration with MSEDCL billing system.

3) New consumer registration: Newly added consumers will be registered on MSEDCL New Connection (NC) system. Prepaid application should fetch data of newly registered consumers from this system and the same shall be updated in the database through web service.

4) Meter assignment/replacement: If meter of consumer is replaced in the field and/or connection type is changed from postpaid to prepaid,

TECHNICAL SPECIFICATION OF SINGLE PHASE 10-60 AMPS PREPAID METER

then same shall get updated in prepaid application through integration with MSEDCL New Connection / Meter replacement system.

- 5) **Tariff Change/Consumer category Change:** If tariff of consumer is changed in billing system, same shall get updated in prepaid application through integration with billing system. Also consumer status such as Live, PD, TD etc. as per billing system will be updated in prepaid application through integration with billing system.
- 6) **Recharge Facility:** A consumer should recharge his account through cash/cheque/Net banking/Credit Card/Debit Card/E- wallets/UPI etc. The balance available for that consumer will be updated accordingly after recharge is made. Also the mode of payment i.e. cash/cheque/Net banking/Credit Card/Debit Card/E-wallets/UPI should be captured and updated properly.
- 7) Consumer should be able to view history of recharges made from time to time.
- 8) When the balance remaining will reach to threshold limits, consumer should be notified through SMS.
- 9) Prepaid application should update the energy parameters such as billing, bill history, load survey data and tamper data received from meter into the database along with relevant details. This data should be exported to Text/PDF/Excel format declared by MSEDCL.
- 10) The prepaid application shall create one single file for the uploaded billing data, in ASCII format or XML file as per MIOS for individual meter reading. The billing data format is as follows:

- i. Reading captured from prepaid meters shall be submitted in one line per meter reading in following format for billing.

Parameter	Length	Position	Remark
Record Type	4 Char	01-04	PP01/PP03 (Refer table of Record Types)
Consumer Number	12 chars	05-16	Left Padded with zeros (0)
Make Code	5 chars	17-21	Shall be provided to successful bidder by MSEDCL.
Meter ID(Serial No)	8 chars	22-29	Left Padded with zeros (0)
Current Reading date	8 chars	30-37	DDMMYYYY format
Current kWh reading	8 chars	38-45	Left Padded with zeros (0)
Current KW MD	4 chars	46-49	Left Padded with zeros (0) with decimal part if any
Current KW MD date	8 chars	50-57	DDMMYYYY format
Current KW MD time	4 chars	58-61	HHMI format

ii. Last Line in bill string (Meter Reading) file, will be the check sum logic output as follows:

- Character 1 to 4 (4 characters): will be (PPT1/PPT3). (Refer table of record types)
- Character 5 to 12 (8 characters): Count of Meter Serial Number, left padding by 0.
- Character 13 to 28 (16 characters): Sum of KWh of all above meters. Total length will be 16, left padding with 0.
- Character 29 to 36 (8 characters): Sum of KW MD, total length will be 8, left padding with 0.
- Character 37 to 61 (25 characters): All zeros.

iii. Table of Record Type

Source	Type	Record Type	Prefix Required
Prepaid	Single Phase	Data	PP01
Prepaid	Single Phase	Control Record	PPT1

11) TARIFF STRUCTURE :

The web based prepaid application shall be programmable for tariff structure, tax / rebate, duty, tariff slabs etc, as per the orders given by MERC from time to time. There should be facility to define tariff structure for different tariff categories e.g. residential, commercial, Industrial, temporary-others, temporary-religious etc. Also there should be provision to update tariff structure as per MSEDCL requirements. The tariff structure should include following parameters.

a) **Fixed Charges:**

Prepaid application shall be able to deduct Fixed charges as a whole for the full month as per the applicable Tariff at the beginning of month.

b) **Energy Charges :**

The software shall have capability for defining minimum six tariff slabs. These slabs will be based on number of energy units consumed. It shall be possible to change the slabs. The tariff shall be applicable for the full month as per the tariff category.

c) **Electricity Duty:**

It shall be possible to define electricity duty percentage through prepaid application which will be levied on recharge amount. The electricity duty rate will depend upon applicable tariff category.

d) **Taxes:**

There shall be provision to define various taxes in online prepaid application which has to be levied on recharge amount. E.g. Tax on sale of electricity (ToSE), if applicable.

e) **Fuel Cost:**

The software shall have provision to define fuel cost charges for different tariff categories. These charges will be deducted from the balance of the consumer as per units consumed.

f) **Wheeling Charges:**

There shall be provision to define wheeling charges for different tariff categories. These charges will be deducted from the balance of the consumer as per units consumed.

g) **Online Payment Discount:**

The software shall have facility to define online payment discount percentage on recharge amount. Accordingly, the discount amount shall be calculated on recharge amount, if paid online.

h) **Rebate:**

The software shall have facility to define rebate percentage on recharge amount. Accordingly, the rebate shall be given on recharge amount.

i) **Debt Management:**

It shall be possible to collect the Debt from the consumers with the use of the online vending system. The Debt percentage shall be defined in the vending system.

12) EMERGENCY CREDIT :

Prepaid application shall be capable to configure for Emergency credit limit so that some defined amount could be provided to the consumer after zero balance. The amount of emergency credit will be decided by MSEDCL. When the balance of the consumer reaches to zero, the meter should not disconnect the power supply and the consumer can avail electricity until emergency credit is consumed. The amount of emergency credit should be deducted from the next recharge amount and the remaining amount should be updated against the balance.

13) HAPPY HOURS :

Prepaid application shall be programmable for happy hours and a command to disconnect power supply shall not be sent by the prepaid engine during happy hours, even if the balance of the consumer is reduced to zero. The happy hours are 17:30 to 11:00 on week days. On Sunday and fixed holidays, the happy hours are entire 24 hours. The power supply should be disconnected after the end of such happy hours. When the consumer account is recharged with new credit, it shall adjust the debited amount first and the remaining amount will be updated against the credit balance.

14) Prepaid application should generate all required reports as per

MSEDCL requirements. The reports should be exported in text/excel and PDF formats.

15) In case of meters are not communicating with server, exception report should be generated by prepaid application showing list of prepaid meters not online. Also the concerned MSEDCL officer should be notified through SMS if there is communication failure between meter and server continuously for one day.

16) It is also possible to schedule the meters for downloading of billing, bill history, tamper and load survey data on demand through this application.

17) Data upload: In case meters are not communicating with server, meter data such as energy parameters, tamper data, load survey data will be downloaded through optical port and there shall be provision to upload the same. The energy parameters uploaded will be passed to prepaid engine to update the balance of consumer.

18) Dash boards: The information available in the database should be displayed in the form of dash board as per MSEDCL requirements.

19) Monitoring and control: MSEDCL users should be able to monitor and control the prepaid metering solution.

20) Integration with MSEDCL systems: Prepaid application should be integrated with MSEDCL billing system, MSEDCL New Connection (NC) system & MSEDCL MDAS through web services. Details of new consumers registered, meter replacement, tariff change etc. should be updated in prepaid application from MSEDCL New Connection (NC) system & Billing system through web services. Meter data such as billing data, instantenous data, bill history, event information & load survey data available in prepaid application should be integrated with MSEDCL MDAS through web services.

21) Mobile App: Prepaid application functionality should also be provided through mobile application working on android and iOS. Prepaid functionalities such as prepaid recharge, view existing balance, daily usage etc. should be incorporated in MSEDCL Consumer mobile application. Consumer should be able to view information related to consumption, recharges done, instantaneous balance available etc. through mobile application. Also alerts, notifications or messages should be given to consumer through mobile application.

MSEDCL may suggest changes in above functionalities, reports in prepaid application/mobile app. Also MSEDCL may introduce new

functionalities. The bidder shall modify the prepaid application/mobile app as per the MSEDCL requirements.

The bidder shall hand over the source code of web based prepaid application to MSEDCL along with necessary credentials, documentation and training.

12.00 PREPAID ENGINE

12.01 The bidder shall develop prepaid engine which will be installed on central server at MSEDCL data centre/MSEDCL cloud. This engine should be multi threaded application which is continuously communicating with prepaid meters and working in synchronization with prepaid application. Prepaid engine should replicate the accounting process done at meter end to server. Functionalities of prepaid engine should be as follows:

12.02 **Deduction from balance:** Based on the meter data received from meter, prepaid engine should calculate the amount for energy consumed for that interval as per the applicable tariff and this amount should be deducted from the available balance of the consumer.

12.03 When the balance reaches to zero, the command should be sent to meter to disconnect the supply. If consumer recharges his account then command to reconnect supply should be sent by the system. Also it should be possible to connect/disconnect the supply of consumer on demand.

12.04 Billing, bill history, Tamper and load survey data received from the meter should be passed over to prepaid application.

12.05 MSEDCL may suggest changes in above functionalities. The bidder shall be agree to modify the prepaid engine functionalities as per MSEDCL requirements.

12.06 The bidder shall hand over the source code of prepaid engine to MSEDCL along with necessary credentials documentation and training.

13.00 PREPAID AND CONNECT/DISCONNECT FEATURES

13.01 Disconnection Mechanism:

Meter should support disconnection under following conditions:

- a. Over current
- b. Load Control Limit (Programmable and set by MSEDCL)
- c. Pre-programmed event conditions
- d. Disconnection signal from Prepaid Engine (Remote disconnection on

demand) or from optical port.

- e. In case of balance of consumer reduced to zero

13.02 Reconnection Mechanism:

Meter should support reconnection under following conditions:

- a. Local reconnection due to disconnection under over current & load control limit.
- b. Remote reconnection, after receipt of command from prepaid engine, when consumer recharges account.
- c. Reconnection after receipt of command through optical port.

14.00 TAMPER & FRAUD MONITORING FEATURES:

14.01 ANTI TAMPER FEATURES

The meter shall detect and register the energy correctly only in forward direction under any one or combination of following tamper conditions:

- (i) Reversal of phase & neutral.
- (ii) Reversal of line and load terminals: Even on interchanging the load and line wires, the meter shall register correct energy passing through the meter.
- (iii) Drawing of current through local Earth: the meter shall register accurate energy even if load is drawn partially or fully through a local earth.
- (iv) Where neutral is disconnected from the load side or from the supply side or both, the load and supply side, the meter shall disconnect the load from supply side as the latching relay in phase & neutral cannot be operated
- (v) The meter shall work without earth.
- (vi) All the above tampers will be verified at basic current at reference voltage

The potential link shall not be provided on terminal block outside the main meter cover.
- (vii) Visual indication shall be provided to safeguard against wrong connections to the meter terminals.
- (viii) The meter shall be immune to the external magnetic field (AC / DC / Permanent) upto 0.2 Tesla. If the accuracy of the meter gets affected under the influence of magnetic field more than 0.2 Tesla, then the same shall be recorded as magnetic tamper event

TECHNICAL SPECIFICATION OF SINGLE PHASE 10-60 AMPS PREPAID METER

with date & time stamping and the meter shall record energy considering the maximum value current (I_{max}) at ref. voltage and unity power factor.

- (ix) The meter shall be immune to abnormal voltage / frequency generating devices.
- (x) The meter shall remain immune for the test of electromagnetic HF/RF defined under the test no. 4.0 mentioned in table 20 for EMI/EMC of IS 13779:1999 amended up to date.
- (xi) In the event the meter is forcibly opened, even by 2 to 4 mm variation of the meter cover, same shall be recorded as tamper event with date & time stamping and the meter shall continuously display that the cover has been tampered. It is suggested that the manufacturer shall develop their software such that there will be some time delay for activation of this tamper feature and during that period only the meter cover shall be fitted. The delay in activation of software shall be for one instance only. After the meter cover is fitted, it shall get activated immediately without any delay. The delay in activation of software shall be for one instance only.
- (xii) The energy meter shall have the facility to detect the above tampers stored in meter tamper data

For above abnormal conditions, the recording of events shall be on FIFO basis.

Event data should be immediately pushed by the meter to prepaid server on occurrences and restorations of events. Also it shall be possible to retrieve the abnormal event data along with all related snap shots data through optical port and upload the same to web based prepaid application.

15.00 DISPLAY OF MEASURED VALUES

- 15.01 The display shall be permanently backlit LCD, visible from the front of the meter. The display shall be electronic and when the meter is not energized, the electronic display need not be visible.

15.02 MINIMUM CHARACTER SIZE:

The energy display shall be minimum 5 digits. The height of the display characters for the principal parameters values shall not be less than 5 mm. The size of digit shall be minimum 9 x5 mm.

- 15.03 The principal unit for the measured values shall be the kilowatt hour

TECHNICAL SPECIFICATION OF SINGLE PHASE 10-60 AMPS PREPAID METER

(kWh) and the maximum demand in kW (kWMD) along with the time.

15.04 The decimal units shall not be displayed for cumulative kWh in auto scroll mode. However it shall be displayed in push button mode for high resolution display for testing.

15.05 The meter shall be pre-programmed for following details.

Voltage: 240 V

Integration period for kWMD shall be of 30 minutes real time based.

The meter shall auto reset kW maximum demand (KW MD) at 2400 Hrs. of last day of each calendar month and this value shall be stored in the memory along with the cumulative kWh reading. No reset push button shall be provided.

The Default Display (Auto scrolling mode) shall switch to Alternate Display (On Demand Display Mode) after pressing the push button continuously for 5 seconds.

The Alternate Display (On Demand Display Mode) shall switch over to Default Display if the push button is not operated for 15 seconds.

15.06 The meter shall have facilities to measure, record and display the parameters as per IS: 16444 / 2015 of the latest version.

Where multiple values are presented by a single display, all relevant values shall be available via appropriate selection (choice of selection shall be general, for example push button).

15.07 The register shall be able to record and display starting from zero, for a minimum of 1500 h, the energy corresponding to maximum current at reference voltage and unity power factor. The register shall not rollover during this duration.

15.08 DISPLAY INDICATORS:

The following shall be displayed permanently by LED / LCD as a minimum and shall be visible from the front of the prepaid meter.

- a. Supply indication.
- b. Relay status.
- c. Earth load indication (if condition occurred).
- d. Meter cover forcibly open tamper event

The meter shall be provided with LEDs to indicate communication in progress. Two separate LED indicators should be provided for data transmission (TxD) mode and data receiving (RxD) mode.

15.09 The display parameters shall be preprogrammed at factory.

15.10 MINIMUM DISPLAY CAPABILITY (MEASURING PARAMETERS):

Display other than specified below shall be blocked.

(A) DEFAULT DISPLAY (AUTO SCROLL MODE):

The following parameters shall be capable of being displayed on the prepaid meter in default display (auto scroll mode).

(a)	Active Energy
	(a) Cumulative kWh
	(b) Units in kWh

(B) ALTERNATE DISPLAY (ON DEMAND DISPLAY MODE) (PUSH BUTTON MODE):

The following parameters shall be capable of being displayed by prepaid meter in alternate display by push button

(a)	Date & time
(b)	LCD check
(c)	Sr. No. of meter
(d)	Instantaneous Voltage
(e)	Instantaneous Current
(f)	High Resolution kWh with two decimal points
(g)	Software version of meter
(h)	Power ON Hours
(i)	No. of switch open or close operations
(j)	Maximum current & load limit set in meter
(k)	Maximum current recorded
(l)	kWMD information along with date & time
(m)	Consumption history for last 12 months (kWh).
(n)	Tamper Events

(o)	Meter Cover Open Tamper Event
-----	-------------------------------

16.00 BILLING DATA, BILLING HISTORY, LOAD SURVEY & TAMPER DATA

16.01 BILLING DATA

The billing data is summarized as below.

Sr. No.	Parameters
1.0	Real Time Clock- Date & Time
2.0	Cumulative Energy – kWh
3.0	Cumulative Energy – kWh for TZ1
4.0	Cumulative Energy – kWh for TZ2
5.0	Cumulative Energy – kWh for TZ3
6.0	Cumulative Energy – kWh for TZ4
7.0	Cumulative Energy – kVAh
8.0	Cumulative Energy – kVAh for TZ1
9.0	Cumulative Energy – kVAh for TZ2
10.0	Cumulative Energy – kVAh for TZ3
11.0	Cumulative Energy – kVAh for TZ4
12.0	Maximum demand (kW MD) with date & time.
13.0	Maximum demand (kW MD) with date & time for TZ1.
14.0	Maximum demand (kW MD) with date & time for TZ2.
15.0	Maximum demand (kW MD) with date & time for TZ3.
16.0	Maximum demand (kW MD) with date & time for TZ4.
17.0	Billing Power ON Duration in Minutes (During billing period)

16.02 BILLING HISTORY:

The meter shall have sufficient non-volatile memory for recording history of billing parameters (as per above table) for last 12 months.

16.03 INSTANTANEOUS PARAMETERS:

Instantaneous parameters are summarized as below.

Sr. No.	Parameters
1.0	Real Time Clock- Date & Time
2.0	Voltage
3.0	Phase Current
4.0	Neutral Current
5.0	Signed Power Factor
6.0	Cumulative Energy – kWh
7.0	Cumulative Energy – kVAh
8.0	Maximum demand (kW MD)
9.0	Cumulative Power ON Duration in Minutes
10.0	Cumulative Tamper Count
11.0	Cumulative Billing Count
12.0	Load Limit Function Status
13.0	Load Limit Value in kW
14.0	Relay (Load Switch) Status

For parameter No. 12 & 14 the value will be 1 if relay (load switch) is connected and 0 if disconnected

16.04 LOAD SURVEY PARAMETERS:

The load survey parameters shall be as given below.

(1)	Real Time Clock – Date and Time
(2)	Average Voltage

(3)	Block Energy – kWh
(4)	Block Energy – kVAh

The logging interval for load survey shall be 30 minutes. Load survey data shall be logged for 45 'Power On' days on non time based basis, i.e. if there is no power for more than 24 hours, the day shall not be recorded. Whenever meter is taken out and brought to laboratory the load survey data shall be retained for the period of actual use of meter. This load survey data can be retrieved as and when desired and load profiles shall be viewed graphically / analytically with the help of meter application software. The meter application software shall be capable of exporting / transmitting these data for analysis to other user software in spreadsheet format

16.05 TAMPER DATA:

Event data (as per clause No. 14) should be immediately pushed by the meter to prepaid server on occurrences and restorations of events. Also it shall be possible to retrieve the abnormal event data along with all related snap shots data through OPTICAL port and upload the same to web based prepaid application.

17.00 DEMONSTRATION

The purchaser reserves the right to ask for the demonstration of the equipment offered at the purchaser's place.

18.00 CONNECTION DIAGRAM AND TERMINAL MARKINGS

The connection diagram of the meter shall be clearly shown on inside portion of the terminal cover and shall be of permanent nature. Meter terminals shall also be marked and this marking shall appear in the above diagram. The diagram & terminal marking on sticker will not be allowed.

20.00 MARKING OF METER

20.01 NAME PLATE

Meter shall have a name plate clearly visible, effectively secured against removal and indelibly and distinctly marked with all essential particulars as per relevant standard. The manufacturer's meter constant shall be marked on the Name Plate.

In addition to the requirement as per IS, following shall be marked on the Name Plate.

Purchase Order No.

Month and Year of manufacture

Name of purchaser i.e. MSEDCL

Guarantee Five Years

ISI mark

Communication Technology with Carrier frequency

The meter Serial No. shall be Bar Coded along with Numeric No. The size of Bar Code shall not be less than 35x5 mm. Stickers for meter serial no., in any case will not be accepted.

A sticker label containing warning notice in Marathi language which is to be stick up on meters front cover or printed on meter name plate with easily readable font size not less than 10 in red colour, which reads as “सावधान ! मीटरला फेरफार करण्याचा प्रयत्न केल्यास अधिकतम वेगाने वीज नोंदणी होणार.”

21.00 TESTS

21.01 TYPE TESTS

The prepaid meter to be supplied shall be fully type tested for the properties / requirement as per IS: 16444/2015, IS 15884 / 2010 and all relevant IS and IEC of the latest version and external AC / DC magnetic influence tests as per CBIP Tech – Report 325 with latest amendments. Type test certificate shall be submitted before commencement of supply and the same shall not be more than 5 years old at the time of commencement of supply. The Type Test Reports shall clearly indicate the constructional features of the type tested meter.

The Type Test Certificate as per IS: 16444 / 2015 (For the purpose of IS 16444/2015 all definitions given in IS 16444 shall apply) shall be submitted along with the offer. Separate Type Test Reports for each type of meter to be supplied shall be submitted. All the Type Tests shall have been carried out from Laboratories which are accredited by the National Accreditation Board for Testing and Calibration Laboratories (NABL) of Govt. of India such as CPRI, Bangalore / Bhopal, ERDA Vadodara, ERTL to prove that the meter to be supplied meets the requirements of the specification. Type Test Reports conducted in manufacturers own laboratory and certified by testing institute shall not be acceptable. Type Test for prepaid features as per IS shall be confirmed for the parameters indicated elsewhere in the specification also at manufacturers' lab during inspection.

All The type test reports including additional acceptance tests of meter to be supplied shall be got approved from Chief Engineer, Testing & Quality Control before commencement of supply.

The purchaser reserves the right to demand repetition of some or all the type tests in presence of purchaser's representative at purchaser's cost.

21.02 Meters to be supplied shall pass all the acceptance and routine test as laid down in IS: 15884 / 2010 of the latest version and also additional acceptance tests as prescribed in this specification. (3 to 8 meter from a lot more than 1,000 shall be sealed randomly in the factory and will be tested for tamper events.)

21.03 ADDITIONAL ACCEPTANCE TESTS:

The following additional tests on meter to be supplied shall be carried out in addition to the acceptance tests specified in IS: 15884 / 2010 of the latest version.

(a) ACCEPTANCE TEST FOR PREPAID FEATURES:

- i) Test of credit balance & debit.
- ii) Test of friendly credit hours, Start & end time there of
- iii) Test of disconnect the output supply when credit reach to zero.
- iv) Test of reconnect the output supply on providing credit limit.
- v) Test of disconnect output supply if load / current exceeded the preset value in the meter.
- vi) Test of reconnect output supply if load / current falls below the preset value in the meter.
- vii) Test of application of tariff.

(b) OTHER ACCEPTANCE TESTS:

- i) Glow wire testing for polycarbonate material.
- ii) The meter shall withstand continuously for a period of at least 5 minutes at a voltage of 440V between phase and neutral without damage/problems,
- iii) Tamper conditions as stated in this specification,
- iv) Power consumption tests,
- v) The meter to be supplied shall comply all the tests for external AC / DC magnetic field as per CBIP Tech Report 325 with latest amendments. Moreover, the magnetic influence test for permanent magnet of 0.5 T for minimum period of 15 minutes

TECHNICAL SPECIFICATION OF SINGLE PHASE 10-60 AMPS PREPAID METER

shall be carried out, by putting the magnet on the meter body. If the accuracy of the meter gets affected during the test, then the same shall be recorded as magnetic tamper event with date & time stamping and the meter shall record energy considering I_{max} and reference voltage at unity power factor. After removal of magnet, meter shall be subjected to accuracy test as per IS: 15884 / 2010 of the latest version. No deviation in error is allowed in the accuracy as per specifications.

- vi) The meter shall withstand impulse voltage at 6 kV.
- vii) The meter shall remain immune for the test of electromagnetic HF/RF defined under the test no. 4.0 for EMI/EMC of IS 13779:1999 amended up to date. For any higher signals than the present standards and MSEDCL technical specifications indicated above.

The test as per clause no. 26.03 (c) (i) to (iv) shall be carried out at factory for each inspected lot at the time of pre-dispatch inspection.

The tests as per clause no. 26.03 (c) (v), (vi) & (vii) shall be carried out on one sample from first lot as per procedure laid down in IS: 15884 / 2010 of the latest version and CBIP Tech. Report - 325 in NABL LAB. The test report shall be got approved from Chief Engineer, Testing & Control Cell before commencement of supply.

21.04 LIMITS OF ERROR:

Limits of variation in percentage error due to change in voltage shall not exceed the values given in the following table

Sr. No.	Influence quantities	current Value	Power factor	Limits of variation in % error for class 1 meters
a)	Voltage variation - 15% to +10%	I_b	1	0.7
		I_b	0.5 lag	1.0
b)	Voltage variation - 40% & + 20%	I_b	1	1.1
		I_b	0.5 lag	1.5

- (i) The meter shall be tested at (-) 15% and at (-) 40% of reference voltage as well as (+) 10% and (+) 20% of reference voltage and shall record energy within limits of variation indicated above. However the meter shall continue to register energy up to 50% of the rated voltage.
- (ii) For other influence quantities like frequency variation the limits of variation in percentage error will be as per IS: 15884 / 2010 of the

latest version.

22.00 GUARANTEED TECHNICAL PARTICULARS

The tenderer shall also furnish the particulars giving specific required details of Meter in schedule 'A' attached. The offers without the details in Schedule 'A' stands rejected.

23.00 TENDER SAMPLE

Tenderer are required to submit 11 (Eleven) nos. of sample meters as per IS: 16444 / 2015 (amended upto date) with communication module as per technical specification with valid type test certificates as per IS: 16444 / 2015 (amended upto date), CBIP tech report 325 (amended upto date) from any of the NABL accredited Lab & valid BIS certificate, connecting telephonic cable with connectors fixed to cable, API / Exe file with documentation and web based prepaid application prepaid engine, documentation, Exe / API for validating downloaded meter data, etc. of each offered type / item along with their offer to EE (SM) in the office of the Chief Engineer, MSEDCL, Material Management Cell, 1st Floor, Prakashgad, Bandra (E), Mumbai – 400 051 on or before the time & date stipulated for submission of offer for testing the sample meters in third party NABL Lab like CPRI, ERDA, ERTL, etc. and testing the offered API with BCS and vending software & documentation etc. by our IT Department as per technical specifications for testing of data downloading and prepaid features etc. The type tests carried out as per IS: 16444 / 2015 (amended update) during last five years from the date of opening of the tender shall be valid. The offer of those eligible bidders shall only be considered if the meter sample passes the tests at NABL Lab & MSEDCL IT Section. The results of NABL Lab & MSEDCL IT Section shall not be disputed and shall be binding on the bidder.

The required information such as Manufacturer's Name or Trade Name, Sr. No., ISI Certification No. etc. shall be on stickers to be affixed on outer portion of sample meters being submitted along with the offer. Such information shall not be embossed or printed on any part of the sample meter.

Out of these, two samples shall be without Ultrasonic welding to confirm constructional features.

24.00 PRE DESPATCH INSPECTIONS

All acceptance tests and inspection shall be carried out at the place of manufacturer unless otherwise specially agreed upon by the manufacturer and purchaser at the time of purchase. The

manufacturer shall offer to the inspector representing the purchaser, all the reasonable facilities, free of charge, for inspection and testing, to satisfy him that the material is being supplied in accordance with this specification.

The Company's representative / Engineers attending the above testing shall carry out testing on suitable number of meters as per sampling procedure laid down in IS: 15884 / 2010 of the latest version and additional acceptance test as per this specification and issue a test certificate approval to the manufacturer and give clearance for dispatch. All the meters offered for inspection shall be in sealed condition. The seals of sample meter taken for testing & inspection shall be break open & resealed after inspection. The routine tests of latching relay shall also be carried out & confirmed. The first lot of meter may be jointly inspected by the Executive Engineer, Testing Division and the Executive Engineer, Inspection Wing.

25.00 INSPECTION AFTER RECEIPT AT STORES (RANDOM SAMPLE TESTING)

For carrying out "Random Sample Testing (RST), the sample meter will be drawn from any one of the stores against inspected lot and same shall be tested at respective Testing and Quality Assurance units at Aurangabad, Bhandup, Kolhapur, Nagpur, Nashik & Pune. Sample meter shall be drawn as per Appendix "H" of IS: 13779 / 1999 (amended up to date). Sample meter will be tested by MSEDCL Testing Engineer in presence of supplier's representative jointly for (i) starting current, (ii) Limits of error, (iii) Repeatability of error, (iv) No Load Test as per IS: 15884 / 2010 of the latest version (v) Test for prepaid feature as per clause no. 26.03 (a). The RST shall be carried out by the Testing Division allotted by Chief Engineer, MM Cell.

The 5 days advance intimation shall be given to the supplier and if the supplier fails to attend the joint inspection on the date informed, the testing will be carried out by our testing engineer in absence of supplier's representative. If the meter fails in above random sample testing, the lot will be rejected.

26.00 TRAINING

The bidder / manufacturer shall arrange various training programmes for administration training, user training and trouble shoot training free of cost with supported documents like system software manual, system operation manual. Training shall be imparted to at least 100 officers for user training and at least 5 officers for administration training.

27.00 GUARANTEE

The prepaid meters with communication module and allied software / hardware shall be guaranteed for the period of five years from the date of successful commissioning certificate from the concerned Circle Office of MSEDCL or five and half years from the date of dispatch whichever is earlier.

28.00 PACKING

28.01 The prepaid meter with communication module, CMRI etc. shall be suitably packed in order to avoid damage during transit or handling. Each meter and CMRI may be suitably packed in the first instance to prevent ingress of moisture and dust and then placed in a cushioned carton of a suitable material to prevent damage due to shocks during transit.

The lid of the carton may be suitably sealed. A suitable number of sealed cartons may be packed in a case of adequate strength with extra cushioning.

The cases may then be properly sealed against accidental opening in transit. The packing cases may be marked to indicate the fragile nature of the contents.

28.02 The following information shall be furnished with the consignment:

- (i) Name of the consignee
- (ii) Details of consignment
- (iii) Destination
- (iv) Total weight of the consignment
- (v) Sign showing upper / lower side of the crate
- (vi) Sign showing fragility of the material
- (vii) Handling and unpacking instructions
- (viii) Bill of Material indicating contents of each package and spare material.

29.00 QUALITY CONTROL

29.01 The purchaser has a right to send a team of experienced engineers for assessing the capability of the firm for manufacturing and testing of meters as per this specification.

The team shall be given all assistance and co-operation for inspection and testing at the bidder's works.

29.02 Meters supplied shall give service for a long period without drifting from original calibration & performance must be near to zero percent failure.

30.00 MINIMUM TESTING FACILITIES

30.01 Manufacturer shall possess fully computerized automatic Meter Test Bench System having in-built constant voltage, current and frequency source with facility to select various loads automatically and print the errors directly for carrying out routine and acceptance Tests as per IS: 15884 / 2010 of the latest version. Test Reports for each and every meter shall be generated. The list of testing equipments shall be enclosed.

30.02 The manufacturer shall have the necessary minimum testing facilities for carrying out the following tests:

- a) Insulation resistance measurement
- b) No load condition
- c) Starting current
- d) Accuracy requirement
- e) Power consumption
- f) Repeatability of error
- g) Transportation test – as per clause no. 26.03 (b)
- h) Tamper conditions - as per clause no. 15.00
- i) Prepaid Feature Testing Facility as per clause no. 26.03 (a) & IS.
- j) The manufacturer shall have duly calibrated RSS meter of class 0.1 or better accuracy.
- k) The manufacturer shall have Glow Wire Testing facility

30.03 METER SOFTWARE

The Bidders will have to get appraised & obtain Capability Maturity Model Integration CMMI – Level III as on the date of tender.

31.00 MANUFACTURING ACTIVITIES

The manufacturer shall submit the list of plant and machinery along with the offer.

A. Meter shall be manufactured using SMT (Surface Mount Technology) components and by deploying automatic SMT pick and place machine and reflow solder process. The loops/wired joints must be avoided on PCB. Further, the Bidder shall own or have assured access (through hire, lease or sub-contract, documentary proof shall be attached with the offer) of above facilities.

B. Quality shall be ensured at the following stages:

TECHNICAL SPECIFICATION OF SINGLE PHASE 10-60 AMPS PREPAID METER

- a) At PCB manufacturing stage, each Board shall be subjected to computerized bare board testing.
- b) At insertion stage, all components shall undergo computerized testing for conforming to design parameter and orientation
- c) Complete assembled and soldered PCB shall undergo functional testing using Automatic Test Equipments (ATEs).
- d) Important:

Prior to final testing and calibration, all meters shall be subjected to ageing test (i.e. Meters will be kept in heating chamber for 72 hours at 55° C temperature at full load current. After 72 hours, meter shall work satisfactory) to eliminate infant mortality.

- C. The calibration of meter shall be done in-house on a computerized testing bench having stabilized power supply.
- D. The bidders shall submit the list of all (imported as well as indigenous) components to be used in meter, separately along with the offer. List of makes of components is attached herewith as a guide line (Annexure - II).
- E. Bought out items:

A detailed list of bought out items which are used in the manufacturing of the meter, shall be furnished indicating the name of firms from whom these items are procured. The bidder shall also give the details of quality assurance procedures followed by him in respect of the bought out items.

- F. List of Plant and Machinery used for Energy meter Production.

Sr. No.	List of Plant and Machinery used for Energy meter Production		
1	Fully automatic testing Bench with ICT for link less meter	testing testing	Routine Testing and Calibration of Meter
2	Semi automatic testing Bench with MSVT	testing	Routine Testing and Calibration of Meter
3	IR Tester		Insulation testing
4	HV Tester		Insulation testing

TECHNICAL SPECIFICATION OF SINGLE PHASE 10-60 AMPS PREPAID METER

5	Error calculators	Error testing
6	Long duration Running test set ups	Reliability Testing
7	Reference Meter class 0.1 accuracy	Error calculation
8	Ultrasonic welding Machines	Welding of meter
9	Automatic Pick And Place Machines	Automatic placing of SMT components
10	Solder Paste Printing Machine	SMT soldering
11	Soldering Furnace IR reflow	SMT soldering
12	PCB Scanner	For testing of PCBs
13	ATE functional tester	For testing of Components
14	Programmiers and Program Loaders	Chip Programming Tools
15	CAD PCB designing setups	PCB designing
16	Furnace IR type for Hybrid Micro Circuits	resistance network and HMC manufacturing
17	Laser Trimming Machines	trimming of resistances for higher accuracy measurement
18	Wave Soldering Machines	Wave soldering of PCBs
19	Humidity Chamber	Accelerated testing for Life cycle
20	Dry Heat Test Chamber	Accelerated testing for Life cycle

TECHNICAL SPECIFICATION OF SINGLE PHASE 10-60 AMPS PREPAID METER

21	Thermal Shock Chamber	Accelerated testing for Life cycle
22	PRO - E Mechanical Design Stations	Mechanical CAD stations
23	Spark Erosion Tool fabricating Machine	Tool fabrication and Die manufacturing
24	CNC wire Cut Tool Fabrication machine	Tool fabrication and Die manufacturing
25	CNC Milling Machine for composite tool fabrication	Tool fabrication and Die manufacturing
26	Injection Moulding Machine	Moulding of plastic parts
27	Vibration testing Machine	Vibration testing of Meter
28	Glow Wire Test machine	Testing of Plastic Material
29	Fast transient burst testing setup	Type testing of Meter
30	Short term over Current testing setup	Type testing of Meter
31	Magnetic and other tamper testing setups	Tamper Testing
32	Impulse Voltage Testing Setup	Type testing of Meter
33	Composite Environmental testing chambers	Type testing of Meter

32.00 QUALITY ASSURANCE PLAN

32.01 The tenderer shall invariably furnish QAP as specified in Annexure - I along with his offer the QAP adopted by him in the process of manufacturing.

32.02 Precautions taken for ensuring usage of quality raw material and sub

component shall be stated in QAP.

33.00 COMPONENT SPECIFICATION

As per Annexure - II enclosed.

34.00 SCHEDULES

The tenderer shall fill in the following schedules and submit along with the offer. If the schedules are not submitted duly filled in with the offer, the offer shall be rejected.

Schedule `A' Guaranteed Technical particulars (As per parameters uploaded on e - Tendering site.)

The discrepancies if any between the specification and the catalogs and/or literatures submitted as part of the offer by the bidders, the same shall not be considered and representations in this regard will not be entertained.

If it is observed that there are deviations in the offer in Guaranteed Technical Particulars other than those specified in the deviation schedules then such deviations shall be treated as deviations.

ANNEXURE - I

Quality Assurance Plan

- A. The bidder shall invariably furnish the following information along with his bid, failing which his bid shall be liable for rejection. Information shall be separately given for individual type of material offered.
- i. Statement giving list of important raw materials, names of sub-suppliers for the raw materials, list of standards according to which the raw materials are tested. List of test normally carried out on raw materials in presence of Bidder's representative, copies of test certificates :
 - ii. Information and copies of test certificates as in (i) above in respect of bought out accessories.
 - iii. List of manufacturing facilities available.
 - iv. Level of automation achieved and list of areas where manual processing exists.
 - v. List of areas in manufacturing process, where stage inspections are normally carried out for quality control and details of such tests and inspections.
 - vi. List of testing equipment available with the bidder for final testing of equipment specified and test plan limitation. If any, vis-a-vis the type, special acceptance and routine tests specified in the relevant standards. These limitations shall be very clearly bought out in schedule of deviation from specified test requirements.
- B. The successful bidder shall within 30 days of placement of order, submit following information to the purchaser.
- i. List of raw materials as well as bought out accessories and the names of sub-suppliers selected from those furnished alongwith offers.
 - ii. Type test certificates of the raw materials and bought out accessories if required by the purchaser.
 - iii. Quality assurance plan (QAP) with hold points for purchaser's inspection. The quality assurance plant and purchasers hold points shall be discussed between the purchaser and bidder before the QAP is finalized.
- C. The contractor shall operate systems which implement the following:
- i. Hold point: A stage in the material procurement or workmanship process beyond which work shall not proceed without the documental approval of designated individuals organizations. The purchaser's

TECHNICAL SPECIFICATION OF SINGLE PHASE 10-60 AMPS PREPAID METER

written approval is required to authorize work to progress beyond the hold points indicated in quality assurance plans.

- ii. Notification point: A stage in the material procurement or workmanship process for which advance notice of the activity is required to facilitate witness. If the purchaser does not attend after receiving documented notification in accordance with the agreed procedures and with the correct period of notice then work may proceed.

D. The successful bidder shall submit the routine test certificates of bought out accessories and central excise passes for raw material at the time of routine testing if required by the purchaser and ensure that Quality Assurance program of the contractor shall consist of the quality systems and quality plans with the following details.

- i. The structure of the organization.

The duties and responsibilities assigned to staff ensuring quality of work.

The system for purchasing taking delivery and verification of material.

The system for ensuring quality workmanship.

The system for retention of records.

The arrangement for contractor's internal auditing.

A list of administration and work procedures required to achieve and verify contract's quality requirements these procedures shall be made readily available to the project manager for inspection on request.

- ii. Quality Plans :

An outline of the proposed work and programme sequence.

The structure of the contractor's organization for the contract.

The duties and responsibilities assigned to staff ensuring quality of work.

Hold and notification points.

Submission of engineering documents required by the specification.

The inspection of materials and components on receipt.

Reference to the contractor's work procedures appropriate to each activity.

Inspection during fabrication / construction.

Final inspection and test.

ANNEXURE - II

Component Specification

The make/grade and the range of the components should be from the following list.

Sr. No.	Component function	Requirement	Makes
1	Measurement or computing chips	The measurement or computing chips used in the Meter shall be with the Surface mount type.	<p>USA: AnalogDevices, Cyrus Logic, Atmel, Philips, Teridian. Dallas, ST, Texas Instruments, Motorola, Maxim, National Semiconductors, Freescale, Onsemiconductors</p> <p>Germany: Siemens.</p> <p>South Africa: SAMES.</p> <p>Japan: NEC, Toshiba, Renasas, Hitachi.</p> <p>Austria: AMS</p> <p>Holland: Philips (N X P)</p> <p>Taiwan: Prolific</p>
2	Memory chips	<p>The memory chips shall not be affected by external parameters like sparking, high voltage spikes or electrostatic discharges. Meter shall have non volatile memory (NVM). No other type of memory shall be used for data recording and programming. (The life of the NVM is highest)</p> <p>There shall be security isolation between metering circuit, communication circuit, and power circuit.</p>	<p>USA: Atmel, Teridian, National Semiconductors, Philips, Texas Instruments, ST, Microchip, Spanson (Fujitsu), Ramtron</p> <p>Japan:Hitachi, Renasas</p> <p>Germany: Siemens</p>
3	Display modules	<p>a) The display modules shall be well protected from the external UV radiations.</p> <p>b) The display visibility shall be sufficient to read the Meter</p>	<p>Display TEK/KCE/RCL Display /Suzhou heng Xiamen instruments/ Veritronics</p> <p>Singapore: E-smart, Bonafied Technologies, Display Tech,</p> <p>Korea:Advantek, Jebon, Union Display Inc.,</p>

TECHNICAL SPECIFICATION OF SINGLE PHASE, 10 - 60 AMPS PREPAID METER

		<p>mounted at height of 0.5 meter as well as at the height of 2 meters (refer 3.2 d for viewing angle).</p> <p>c) The construction of the modules shall be such that the displayed quantity shall not be disturbed with the life of display (PIN Type).</p> <p>d) It shall be trans-reflective HTN (HTN – Hyper Twisted Nematic (120°)) or STN (STN – Super Twisted Nematic (160°)) type industrial grade with extended temperature range. HTN – Hyper Twisted Nematic (120°) STN – Super Twisted Nematic (160°)</p>	<p>Japan: Hitachi, Tianma, Sony, L&G, Holtek, Haijing.</p> <p>Malaysia: Crystal Clear Technology.</p> <p>Hong kong: Genda</p> <p>China: Success, Tianma</p>
4	Electronic components	<p>The active & passive components shall be of the surface mount type & are to be handled & soldered by the state of art assembly processes.</p>	<p>USA: National Semiconductors, Atmel, Philips, Texas Instruments, BC Component Analog devices, ST, Maxim, Siemens, PHYCOMP, YAGEO, DRALORIC, KOA, WELWYN, OSRAM, Kemet, Onsemiconductors, Freescale, Intersil, Raltron, Fairchild, Muruta, Agilent, AVX, Abracon, Sipex, Diode Inc., Honeywell, Power Integration, Fox, Roham</p> <p>Japan: Hitachi, Oki, AVZ or Ricon, Toshiba, Epson, Kemet, Alps, Muruta, TDK, Sanyo, Samsung, Panasonic</p> <p>India: Keltron, Incap, VEPL, PEC, RMC, Gujarat Polyavx, Prismatic, MFR Electronic components Pvt. Ltd., Cermet, CTR.</p> <p>Korea: Samsung</p>

TECHNICAL SPECIFICATION OF SINGLE PHASE, 10 - 60 AMPS PREPAID METER

			<p>Germany: Vishay, Epcos, Diotech, Kemet, Infineon</p> <p>Taiwan: Yageo</p>
5	Battery	<p>Only non rechargeable battery shall be used for RTC as well as display in absence of Power since the life & Reliability of these are better than the rechargeable batteries.</p>	<p>USA: Maxell, Renata</p> <p>Japan: Panasonic, Sony, Mitsubishi, Sanyo</p> <p>Germany: Varta, Tedirum</p> <p>France: Saft</p> <p>Korea: Tekcell, Vitzrocell</p>

SCHEDULE 'A'
GUARANTEED TECHNICAL PARAMETERS

ITEM NAME	LT AC SINGLE PHASE, 10 -60 AMPS PREPAID STATIC ENERGY METER AS PER IS: 16444 - 2015 WITH COMMUNICATION MODULE FOR COMMUNICATION FOR USE ON LT CONSUMER INSTALLATIONS	
SR. NO.	GUARANTEED TECHNICAL PARAMETERS	GTP VALUES
1.0	MAKE & TYPE	TEXT
2.0	APPLICABLE STANDARD	TEXT
3.0	ACCURACY CLASS 1.00 (YES/NO)	BOOLEAN
4.0	METER BEARS ISI MARK (YES/NO)	BOOLEAN
5.0	RATED VOLTAGE 240 V (YES/NO)	BOOLEAN
6.0	VOLTAGE RANGE (-) 40% TO (+) 20% OF RATED VOLTAGE (YES/NO)	BOOLEAN
7.0	FREQUENCY 50 HZ +/- 5% (YES/NO)	BOOLEAN
8.0	RATED BASIC CURRENT 10 AMPS (YES/NO)	BOOLEAN
9.0	MAXIMUM CONTINUOUS CURRENT I _{MAX} 60 AMP (YES/NO)	BOOLEAN
10.0	METER WORKS ACCURATELY UPTO 120% OF I _{MAX} , I.E. 48 AMPS (YES/NO)	BOOLEAN
11.0	STARTING CURRENT 0.2 % OF I _B . (YES/NO)	BOOLEAN
12.0	POWER CONSUMPTION IN VOLTAGE CIRCUIT 5 W & 15 VA (YES/NO)	BOOLEAN
13.0	POWER CONSUMPTION IN CURRENT CIRCUIT 11.5 VA (YES/NO)	BOOLEAN
14.0	POWER FACTOR ZERO TO UNITY (ALL LAG OR LEAD) (YES/NO)	BOOLEAN

TECHNICAL SPECIFICATION OF SINGLE PHASE 10 - 60 AMPS PREPAID METER

15.0	STANDARD REFERENCE TEMPERATURE FOR PERFORMANCE IS 27°C (YES/NO)	BOOLEAN
16.0	MEAN TEMPERATURE CO-EFFICIENT DOES NOT EXCEED 0.07% (YES/NO)	BOOLEAN
17.0	TEMPERATURE RISE IS AS PER IS: 15884 / 2010 OF THE LATEST VERSION. (YES/NO)	BOOLEAN
18.0	METER BASE & COVER MADE OF UNBREAKABLE, TOUGH, HIGH GRADE, FIRE RESISTANT TRANSPARENT POLYCARBONATE MATERIAL (YES/NO)	BOOLEAN
19.0	METER BODY TYPE TESTED FOR IP 51 DEGREE OF PROTECTION AS PER IS 12063 (YES/NO)	BOOLEAN
20.0	FURNISH PHYSICAL WATER ABSORPTION VALUE	TEXT
21.0	FURNISH THERMAL HDDT VALUE	TEXT
22.0	FLAMMABILITY V2 (YES/NO)	BOOLEAN
23.0	FURNISH FLAMMABILITY VALUE	TEXT
24.0	GLOW WIRE TEST AT 650° C	TEXT
25.0	TENSILE STRENGTH	TEXT
26.0	FLEXURE STRENGTH	TEXT
27.0	MODULUS OF ELASTICITY	TEXT
28.0	IZOD IMPACT STRENGTH NOTCHED 23° C	TEXT
29.0	FURNISH PHYSICAL WATER ABSORPTION VALUE	TEXT
30.0	TERMINAL BLOCK IS MADE FROM HIGH QUALITY NON-HYGROSCOPIC, FIRE RETARDANT, REINFORCED POLYCARBONATE (NON-BAKELITE) (YES/NO)	BOOLEAN
31.0	MATERIAL OF WHICH TERMINAL BLOCK IS MADE IS CAPABLE OF PASSING TESTS GIVEN IN IS: 13360 (PART 6/SEC 17) FOR A TEMPERATURE OF 135° C AND A PRESSURE OF 1.8 MPA (METHOD A) (YES/NO).	BOOLEAN

TECHNICAL SPECIFICATION OF SINGLE PHASE 10 - 60 AMPS PREPAID METER

32.0	EXTENDED TRANSPARENT TERMINAL COVER IS AS PER CLAUSE NUMBER 4.2.5 OF IS: 15884 / 2010 OF THE LATEST VERSION (YES/NO)	BOOLEAN
33.0	TRANSPARENT TERMINAL COVER IS SEALABLE INDEPENDENTLY (YES/NO)	BOOLEAN
34.0	PROPER SIZES OF GROOVES ARE PROVIDED AT BOTTOM OF TERMINAL COVER (YES/NO)	BOOLEAN
35.0	METER BASE & COVER ARE ULTRA-SONICALLY WELDED (CONTINUOUS WELDING) (YES/NO)	BOOLEAN
36.0	THICKNESS OF MATERIAL FOR METER 2 MM MINIMUM (YES/NO)	BOOLEAN
37.0	SCREWS USED ON TERMINAL COVER FOR FIXING & SEALING IN TERMINAL COVER ARE HELD CAPTIVE IN TERMINAL COVER (YES/NO)	BOOLEAN
38.0	TERMINALS ARE OF SUITABLE RATING & ARE CAPABLE OF CARRYING 120% OF I _{MAX} & MADE OF ELECTRO-PLATED (OR TINNED) BRASS & ARE OF REPLACEABLE TYPE (YES/NO).	BOOLEAN
39.0	TERMINAL BLOCK, TERMINAL COVER, INSULATING MATERIAL RETAINING MAIN CONTACTS IN POSITION & METER CASE ENSURE REASONABLE SAFETY AGAINST SPREAD OF FIRE. THEY DO NOT IGNITE BY THERMAL OVERLOAD OF LIVE PARTS IN CONTACT WITH THEM (YES/NO).	BOOLEAN
40.0	MATERIAL OF TERMINAL BLOCK DOES NOT DEFLECT UNDER HEATING &. TO COMPLY THEREWITH, FULFILLS TESTS SPECIFIED IN 5.2.4 OF IS: 15884 / 2010 OF THE LATEST VERSION (YES/NO).	BOOLEAN
41.0	RTC PRE-PROGRAMMED FOR 30 YEARS DAY / DATE (YES/NO)	BOOLEAN
42.0	MAXIMUM DRIFT OF RTC	TEXT
43.0	RTC HAS LONG LIFE OF 10 YEARS (YES/NO)	BOOLEAN

TECHNICAL SPECIFICATION OF SINGLE PHASE 10 - 60 AMPS PREPAID METER

44.0	PROVISION TO PUT AT LEAST TWO SEALS ON METER (YES/NO)	BOOLEAN
45.0	METER MEMORY HAS DETAILS AS PER CLAUSE NO. 6.16. (YES/NO)	BOOLEAN
46.0	NON-VOLATILE MEMORY IS FOR A MINIMUM PERIOD OF 10 YEARS (YES/NO)	BOOLEAN
47.0	OPERATION INDICATOR PROVIDED IN THE FORM OF BLINKING LED / LCD (YES/NO)	BOOLEAN
48.0	RESOLUTION OF TEST OUTPUTS SUFFICIENT TO CONDUCT SATISFACTORILY ACCURACY TEST AT LOWEST TESTPOINT IN LESS THAN 5 MIN & STARTING CURRENT TEST IN LESS THAN 10 MIN. (YES/NO)	BOOLEAN
49.0	METER CONSTANT INDELIBLY PROVIDED ON NAME PLATE (YES/NO)	BOOLEAN
50.0	PUSH BUTTONS ARRANGEMENT FOR HIGH RESOLUTION READING & SCROLLING THE PARAMETERS IN ALTERNATE DISPLAY (ON DEMAND) MODE	TEXT
51.0	METER ACCURACY DOES NOT GET AFFECTED BY MAGNETIC FIELD FROM ALL SIDES OF METER (YES/NO)	BOOLEAN
53.0	METER CAPABLE TO WITHSTAND PHASE TO PHASE VOLTAGE (440 V) IF APPLIED BETWEEN PHASE TO NEUTRAL FOR CONTINUOUSLY (YES/NO)	BOOLEAN
54.0	POWER SUPPLY UNIT IS TRANSFORMER LESS (YES/NO)	BOOLEAN
56.0	METER IS TAMPER PROOF & NO TAMPERING IS POSSIBLE THROUGH OPTICAL PORT (YES/NO).	BOOLEAN
57.0	DISPLAY PARAMETERS IN METER ARE NOT ACCESSIBLE FOR REPROGRAMMING AT SITE THROUGH ANY KIND OF COMMUNICATION (YES/NO).	BOOLEAN

TECHNICAL SPECIFICATION OF SINGLE PHASE 10 - 60 AMPS PREPAID METER

58.0	COMPLETE METERING SYSTEM & MEASUREMENT NOT AFFECTED BY EXTERNAL ELECTROMAGNETIC INTERFERENCE AS PER CL. NO. 6.25 OF TECH. SPECS. (YES/NO)	BOOLEAN
59.0	METER MEETS REQUIREMENT OF CBIP TECH. REPORT 325 (YES/NO)	BOOLEAN
61.0	METER RECORDS AND DISPLAYS TOTAL ENERGY INCLUDING HARMONIC ENERGY (YES/NO).	BOOLEAN
62.0	METER PCB IS WIRELESS (YES/NO)	BOOLEAN
63.0	METER MANUFACTURED USING SMT (YES/NO)	BOOLEAN
64.0	METER IS CAPABLE OF BEING READ THROUGH IN BUILT COMMUNICATION MODULE AND OPTICAL PORT (YES/NO).	BOOLEAN
65.0	COMMUNICATION MODULE USED IN METER	TEXT
66.0	COMMUNICATION TECHNOLOGY AND COMMUNICATION PROTOCOL USED TO TRANSFER DATA FROM METER TO SERVER	TEXT
67.0	CARRIER FREQUENCY USED FOR DATA COMMUNICATION	TEXT
68.0	BI-STABLE TYPE & MANUFACTURED IN ACCORDANCE WITH INTERNATIONAL STANDARD OF IEC & DIN EN 61810 PART 1 / VDE 0435 PART 201, TWO LATCHING RELAYS FOR PHASE & NEUTRAL ARE PROVIDED (YES/NO).	BOOLEAN
69.0	LATCHING RELAYS MEET OVERLOAD & SHORT CIRCUIT REQUIREMENT OF IEC, DIN EN 61036 / 61037 & ANSI C12 AND CONFIRM TO LOAD SWITCHING CAPABILITIES AS PER RELEVANT IS (YES/NO)	BOOLEAN
70.0	LATCHING RELAYS ARE WITH TRIP-FREE DESIGN AS PER IS (YES/NO).	BOOLEAN

TECHNICAL SPECIFICATION OF SINGLE PHASE 10 - 60 AMPS PREPAID METER

71.0	LATCHING RELAYS ARE DESIGNED & RATED TO MAKE & BREAK AT VREF, I _{MAX} WITH A LINEAR RESISTIVE LOAD AND AT VREF, I _B , 0.4 INDUCTIVE POWER FACTOR FOR 3,000 OPERATIONS (YES/NO).	BOOLEAN
72.0	AS THE BALANCE CREDIT DECREASES BEYOND PRE-DEFINED LEVEL, LATCHING RELAYS DISCONNECT SUPPLY TO LOAD (YES/NO).	BOOLEAN
73.0	METER DISCONNECTS LOAD IN CASE OF EXCEEDING CURRENT LIMIT (120% I _{MAX}) AFTER 1 MINUTE ON STABILIZING THE CURRENT (YES/NO).	BOOLEAN
74.0	COMMUNICATION CAPABILITY OF METER IS BASED ON COMMUNICATION MODULE AND HARDWARE PORT COMPATIBLE WITH OPTICAL PORT SPECIFICATIONS (YES/NO).	BOOLEAN
75.0	COMMUNICATION MODULE IN METER IS ABLE TO TRANSFER DATA TO PREPAID ENGINE AND RECEIVE COMMANDS FROM PREPAID ENGINE (YES/NO)	BOOLEAN
76.0	METER HAS WIRED COMMUNICATION WITH OPTICAL PORT FOR DOWNLOADING ALL TYPES OF DATA FROM THE METER (YES/NO).	BOOLEAN
77.0	METER IS NOT ACCESSIBLE FOR REPROGRAMMING AT SITE THROUGH ANY KIND OF COMMUNICATION FOR ANY ALTERATION IN THE FACTORY SETTINGS (YES/NO).	BOOLEAN
78.0	OPTICAL PORT PROVIDED FOR DATA DOWNLOADING (YES/NO)	BOOLEAN
79.0	SEALING ARRANGEMENT FOR ABOVE PORTS IS PROVIDED (YES/NO)	BOOLEAN
80.0	OPTICAL PORT SUPPORT DEFAULT & MINIMUM BAUD RATE OF 9600 BPS (YES/NO)	BOOLEAN
81.0	TOD TIME ZONES PROVIDED (YES/NO)	BOOLEAN

TECHNICAL SPECIFICATION OF SINGLE PHASE 10 - 60 AMPS PREPAID METER

82.0	PROVISION TO SET MAXIMUM DEMAND INTEGRATION PERIOD AT 30 MINUTE AS PER REQUIREMENT (YES/NO).	BOOLEAN
83.0	AUTO RESET AT 24:00 HRS AT THE END OF EACH BILLING CYCLE OR AT THE END OF CERTAIN PREDEFINED PERIOD (SAY, END OF THE MONTH) IS PROVIDED (YES/NO)	BOOLEAN
84.0	AN LED FOR POWER ON INDICATION IS PROVIDED(YES/NO).	BOOLEAN
85.0	LED PROVIDED FOR POWER ON INDICATION BLINKS DURING COMMUNICATION(YES/NO).	BOOLEAN
86.0	DEBIT LIMIT UPTO FIVE DIGITS INR IS PROVIDED INTO PREPAID ENGINE (YES/NO)	BOOLEAN
87.0	METER IS CAPABLE TO UPDATE CREDIT BALANCE AND BALANCE UNITS VIA PREPAID APPLICATION AND OPTICAL PORT (YES/NO)	BOOLEAN
88.0	PREPAID APPLICATION IS ABLE TO CONFIGUREAMOUNT FOR ENERGY CHARGES, FIXED CHARGES, TAXES ETC. AS PER TARIFF APPLICABLE (YES/NO)	BOOLEAN
89.0	METER DISCONNECTS OUTPUT SUPPLY WHEN CREDIT REACHES TO ZERO EXCEPT EMERGENCY CREDIT LIMIT (YES/NO)	BOOLEAN
90.0	PREPAID ENGINE IS CAPABLE TO CONFIGURE FOR EMERGENCY CREDIT LIMIT BEFORE DISCONNECTION OF OUTPUT SUPPLY AFTER END OF HAPPY HOURS (YES/NO)	BOOLEAN
91.0	PREPAID ENGINE IS ABLE TO EXPORT THE BILLING DATA AS PER MSEDCL FORMAT GIVEN IN CLAUSE NO. 11.05(10) (YES/NO)	BOOLEAN
92.0	ALL ANTI-TAMPER FEATURES AS PER CLAUSE 14.00 ARE PROVIDED (YES/NO)	BOOLEAN

TECHNICAL SPECIFICATION OF SINGLE PHASE 10 - 60 AMPS PREPAID METER

93.0	PERMANENT BACKLIT LCD TYPE DISPLAY IS PROVIDED (YES/NO)	BOOLEAN
94.0	5 NUMBER OF DIGITS FOR ENERGY DISPLAY PROVIDED (YES/NO)	BOOLEAN
95.0	MINIMUM SIZE OF DIGITS (10X5 MM) (YES/NO)	BOOLEAN
96.0	METER PRE-PROGRAMMED FOR (a) 240 V (YES/NO)	BOOLEAN
97.0	(b) INTEGRATION PERIOD OF 30 MIN FOR MD (YES/NO)	BOOLEAN
98.0	(c) AUTO RESET KWMD AT 2400 HRS. OF LAST DAY OF EACH CALENDAR MONTH (YES/NO)	BOOLEAN
99.0	(d) NO RESET PUSH BUTTON PROVIDED FOR MD RESET (YES/NO)	BOOLEAN
100.0	DISPLAY INDICATORS BY LED / LCD PROVIDED AS PER CLAUSE NO. 15.10 (YES/NO)	BOOLEAN
101.0	PARAMETERS IN AUTO SCROLL MODE DISPLAYED FOR MINIMUM 10 SECONDS INCLUDING LCD CHECK (YES/NO).	BOOLEAN
102.0	DEFAULT DISPLAY SWITCHES TO ALTERNATE DISPLAY AFTER PRESSING THE PUSH BUTTON CONTINUOUSLY FOR 5 SECONDS (YES/NO)	BOOLEAN
103.0	ALTERNATE DISPLAY SWITCHES TO DEFAULT DISPLAY IF PUSH BUTTON IS NOT OPERATED FOR 15 SECONDS (YES/NO)	BOOLEAN
104.0	KWMD PROVIDED (YES/NO)	BOOLEAN
105.0	METER HAS NON-VOLATILE MEMORY FOR RECORDING HISTORY OF BILLING PARAMETERS FOR LAST 12 MONTHS (YES/NO).	BOOLEAN
106.0	PROVISION FOR LOAD SURVEY FOR 30 MINUTES & FOR LAST 45 POWER ON DAYS FOR SPECIFIED PARAMETERSON FIFO (YES/NO)	BOOLEAN

TECHNICAL SPECIFICATION OF SINGLE PHASE 10 - 60 AMPS PREPAID METER

107.0	METER RECORDS TAMPER EVENTS AS SPECIFIED IN SPECIFICATION (YES/NO).	BOOLEAN
108.0	METER KEEPS RECORDS FOR MINIMUM 100 EVENTS. (OCCURRENCE + RESTORATION) FOR ABNORMAL CONDITIONS ON FIFO BASIS (YES/NO).	BOOLEAN
109.0	IT IS POSSIBLE TO RETRIEVE ABNORMAL EVENT DATA ALONG WITH ALL RELATED SNAP SHOTS DATA THROUGH OPTICAL PORT AND UPLOAD THE SAME TO PREPAID APPLICATION (YES/NO)	BOOLEAN
110.0	METERING PROTOCOL TO BE IMPLEMENTED BY THE BIDDER	TEXT
111.0	PREPAID ENGINE IS ABLE TO SEND CONNECT/DISCONNECT SIGNAL TO COMMUNICATION MODULE IN METER ACCORDING TO BALANCE OF CONSUMER(YES/NO)	BOOLEAN
112.0	PERMANENT NATURE CONNECTION DIAGRAM OF METER IS SHOWN ON INSIDE PORTION OF TERMINAL COVER (YES/NO)	BOOLEAN
113.0	CLEARLY VISIBLE, EFFECTIVELY SECURED, INDELIBLY & DISTINCTLY MARKED NAME PLATE WITH ALL ESSENTIAL PARTICULARS AS PER RELEVANT STANDARD & SPECIFICATION IS PROVIDED (YES/NO)	BOOLEAN
114.0	METER IS TYPE TESTED (YES/NO)	BOOLEAN
115.0	TYPE TEST REPORT NUMBER & DATE OF METER	TEXT
116.0	GUARANTEE 5 YEARS FROM INSTALLATION OR FIVE & HALF YEARS FROM DATE OF DESPATCH (YES/NO)	BOOLEAN
117.0	15 NOS. OF SAMPLE METERS AS PER IS: 13779 / 1999 (AMENDED UPTO DATE) WITH COMMUNICATION MODULE FOR CONNECTIVITY AS PER TECHNICAL SPECIFICATION ALONG WITH CONNECTING TELEPHONIC CABLE WITH CONNECTORS FIXED TO CABLE, API / EXE FILE WITH DOCUMENTATION, BCS AND VENDING STATION SOFTWARE ETC IS SUBMITTED ALONGWITH OFFER (YES/NO).	BOOLEAN

TECHNICAL SPECIFICATION OF SINGLE PHASE 10 - 60 AMPS PREPAID METER

118.0	IN HOUSE TESTING FACILITIES ARE AVAILABLE FOR (a) INSULATION RESISTANCE MEASUREMENT (YES/NO)	BOOLEAN
119.0	(b) NO LOAD CONDITION (YES/NO)	BOOLEAN
120.0	(c) STARTING CURRENT TEST (YES/NO)	BOOLEAN
121.0	(d) ACCURACY TEST REQUIREMENT (YES/NO)	BOOLEAN
122.0	(e) POWER CONSUMPTION (YES/NO)	BOOLEAN
123.0	(f) TRANSPORTATION TEST (YES/NO)	BOOLEAN
124.0	(g) FULLY COMPUTERISED METER TEST BENCH SYSTEM FOR CARRYING OUT ROUTINE AND ACCEPTANCE TEST IS AVAILABLE (YES/NO)	BOOLEAN
125.0	(h) MANUFACTURER HAS CALIBRATED STANDARD METER OF 0.1 CLASS ACCURACY (YES/NO)	BOOLEAN
126.0	(i) VERIFIATION OF DATA DOWNLOADING WITH COMMUNICATION MODULE (YES/NO)	BOOLEAN
127.0	(j) GLOW WIRE TESTING (YES/NO)	BOOLEAN
128.0	FURNISH PRINCIPLE OF OPERATION OF METER OUTLINING METHODS AND STAGES OF COMPUTATIONS OF VARIOUS PARAMETERS STARTING FROM INPUT VOLTAGE AND CURRENT SIGNALS INCLUDING SAMPLING RATE IF APPLICABLE (YES/NO)	TEXT
129.0	MANUFACTURING ACTIVITIES ARE AS PER CLAUSE 31.00 (YES/NO)	BOOLEAN
130.0	QAP SUBMITTED AS PER ANNEXURE-I (YES/NO)	BOOLEAN
131.0	AGEING TEST IS CARRIED OUT ON METER (YES/NO)	BOOLEAN
132.0	WHETHER YOU AGREE TO SUPPLY METERS AS PER ANEXURE-D, I.E. TECHNICAL SPECIFICATIONS OF THE TENDER. (YES/NO)	BOOLEAN