

**TECHNICAL SPECIFICATIONS OF 11KV, 22KV, 33KV HORN GAP FUSE  
WITH POLYMER INSULATOR**

**MATERIAL SPECIFICATIONS CELL**

TECHNICAL SPECIFICATION  
OF

11KV, 22KV, 33KV HORN GAP FUSE  
WITH POLYMER INSULATOR

**TECHNICAL SPECIFICATIONS OF 11KV, 22KV, 33KV HORN GAP FUSE  
WITH POLYMER INSULATOR**

**Table of Contents**

CLAUSE NO.	CONTENTS	PAGE NO.
1.00	SCOPE	3
2.00	SERVICE CONDITIONS	3
3.00	MATERIALS	3
4.00	PIN INSULATOR	3
5.00	GENERAL REQUIREMENTS	4
6.00	WORKMANSHIP	4
7.00	GALVANIZING	4
8.00	TYPE TESTS	4
9.00	DOCUMENTATION	5
10.00	INSPECTION	5
11.00	SCHEDULE	6
	ANNEXURE - A	7
	SCHEDULE - 'A': GTP 11 KV, 22 KV & 33 KV HORN GAP FUSE WITH POLYMER INSULATOR	8-10
	DRAWING	

**TECHNICAL SPECIFICATIONS OF 11KV, 22KV, 33KV HORN GAP FUSE  
WITH POLYMER INSULATOR**

**1.00 SCOPE**

This specification covers the Design, manufacture testing at works and supply of Horn Gap Fuses with Polymer Insulator of 11kV, 22kV & 33kV voltage class.

**2.00 SERVICE CONDITIONS**

The equipment to be supplied against this Specification shall be suitable for mounting on outdoors structures for protection of transformers and tapping points under the following tropical conditions.

**Environmental Conditions**

- |  |                       |
|--|-----------------------|
| a) Maximum ambient temperature   | 55° C                 |
| b) Maximum ambient temperature in shade  | 45° C                 |
| c) Minimum temperature of air in shade   | 35° C                 |
| d) Maximum daily average Temperature   | 40° C                 |
| e) Maximum yearly weighted average Temperature   | 32° C                 |
| f) Relative Humidity   | 10 to 100 %           |
| g) Maximum Annual rainfall   | 1450 mm               |
| h) Maximum wind pressure   | 150 Kg/m <sup>2</sup> |
| i) Maximum altitude above mean sea level   | 1000 meters           |
| j) Isoceraunic level   | 50 days/year          |
| k) Seismic level (Horizontal acceleration)   | 0.3 g                 |
| l) Climate: Moderately hot and humid tropical climate conducive to rust and fungus growth. |                       |

**3.00 MATERIALS**

The Horn Gap Fuse units shall be manufactured as per details given in the Drawing attached. The various components shall conform to the following Specifications :

- i) M.S. Channel, flat and round conform to I.S. 2062 (2011) amended up to date (structural steel standard quality having tensile strength of 42-54 kg/sq.mm.)
- ii) Bolt and Nuts : These shall conform to the following IS Specifications.  
IS : 1367-2014 (amended upto date)  
IS : 4218-1999 (amended upto date)  
IS : 1363-2018(amended upto date)
- iii) For galvanizing, zinc conforming to Grade 98.5 of IS- 209/1992 (amended up to date) shall be used.
- iv) Arcing Horn & Connectors should be of one piece Aluminium Strip. Aluminium strip should be as per drawing enclosed.

**4.00 PIN INSULATORS**

The pin type insulators used for the Horn Gap Fuse Unit shall conform to IEC: 61109-2008 (amended upto date) in all respects with regard to mechanical and electrical requirements.

**TECHNICAL SPECIFICATIONS OF 11KV, 22KV, 33KV HORN GAP FUSE  
WITH POLYMER INSULATOR**

The electrical characteristics of the insulators shall be as follows :

Sr. No.	System Voltage	Lightning Impulse Withstand Voltage in kV	Power Frequency Withstand Voltage in kV		Power Frequency Flashover Voltage in kV		Creepage Distance in mm	FRP Rod Dia. in mm
			Dry	Wet	Dry	Wet		
1.	11 kV	75	55	35	85	50	320	24
2.	22 kV	125	75	55	120	85	560	34
3.	33 kV	170	95	75	135	95	900	34

Minimum failing loads for Pin Insulators should be 5 kN for 11kV and 10kN for 22kV & 33kV.

### **5.00 GENERAL REQUIREMENTS**

The Horn Gap Fuse sets are required for protection on 11kV, 22kV and 33kV systems. They will be mounted outdoors on suitable structures. These sets will be exposed to atmospheric conditions and therefore, shall be robust in construction. In the drawing, the construction of the fuse units has been shown using Polymer Pin Insulators.

### **6.00 WORKMANSHIP**

The casting shall be of good finish and free from flaws, blow holes and other defects. The edges of the fittings shall be smoothly rounded.

The M.S. flat, round etc. before any work is done on them, shall be carefully leveled, straightened and bent or forged to the shape given in the drawing by methods which will not injure the materials. No rough edges shall be permitted anywhere through out the work.

Similar parts shall be uniform and interchangeable with each other.

The welding work wherever required shall be carried out properly and the same shall not open under climatic conditions.

Holes in channel shall be drilled or machine punched. All burrs left by drilling or punch shall be completely removed. The Bolts and Nuts shall be well forged and free from inequalities, flaws and other defects. The heads shall be solid and in every respect well formed and shall not fail when the bolts are tested to fracture at their full section for Tensile Stress.

The washers shall be clearly cut off or punched and entirely free from cracks after Punching.

### **7.00 GALVANIZING**

All ferrous parts (Bolts, Nuts, Washers, M.S. Flats, Clamps and M.S. round holding clamps etc. for the insulator and Horn Gap Fuses) shall be hot dip galvanized. The galvanizing shall conform to IS : 2633-1986 (amended up to date) in all respect. After galvanizing, the surfaces shall be free from all sharp edges and metal. The threading on nut and bolt shall be cut before galvanizing. The quality of the galvanizing shall be determined by the tests given in IS: 2633 of 1986 (amended up to date). Wherever the welding is done, the galvanizing shall be done after welding.

### **8.00 TYPE TESTS**

#### **8.01 HORN GAP FUSE**

The following Type Tests shall be carried out on HG Fuses as per IS 9385-1980 (Part-II) amended upto date.

- a) Dielectric Tests-
  - i) Lightning Impulse Voltage Withstand Test
  - ii) Dry Power Frequency Voltage Withstand Test
  - iii) Wet Power Frequency Voltage Withstand Test

**TECHNICAL SPECIFICATIONS OF 11KV, 22KV, 33KV HORN GAP FUSE  
WITH POLYMER INSULATOR**

b) Temperature Rise Test shall be done at 100A Current

The manufacturer/tenderer shall clearly indicate what inhouse testing facilities they have for testing the H.G. Fuses.

All the above type tests shall be carried out as per IS 9385-1980 (Part II) amended upto date at laboratories which are accredited by the National Accreditation Board of Testing and Calibration Laboratories (NABL) of Govt. of India. These type tests should have been carried out within five years prior to the date of opening of this tender.

## **8.02 PIN INSULATOR**

The tenderer will clearly & specifically indicate the name of manufacturer of the Pin Insulator. Accordingly following Type Tests shall be carried out on Pin Insulators.

Sr. No.	Type Test	Test Procedure/Standard
1.	Dry Lightning Impulse Withstand Voltage test	IEC 61109 (Clause No. 11.1)
2.	Wet power frequency test	IEC 61109 (Clause No. 11.1)
3.	Damage Limit proof test and test of tightness of the interface between end fittings & Insulator housing	IEC 61109 (Clause No. 11.2)
4.	Radio Interference test	IEC 60437
5.	Recovery of Hydrophobicity test	Annexure 'A'
6.	Chemical Composition test for Silicon Content	Annexure 'A' or any other test method acceptable to the owner
7.	Brittle Fracture resistance test	Annexure 'A'

All the above type tests shall be carried out at laboratories which are accredited by the National Accreditation Board of Testing and Calibration Laboratories (NABL) of Govt. of India. These type tests should have been carried out within five years prior to the date of opening of this tender.

The Tenderer shall submit all the Type Test reports of HG Fuse & Pin Insulators as per relevant IS to the office of the Chief Engineer (Testing & QC) and get it approved as per Tender conditions.

## **9.00 DOCUMENTATION**

The Horn Gap Fuse units shall be manufactured as per details given in the drawing attached. The Tenderer shall furnish following drawings to the office of Chief Engineer (Testing & QC ) and get it approved as per Tender conditions.

- i) GA drawing of Horn Gap Fuse with Polymer Pin Insulator
- ii) Drawing of Polymer Pin Insulator

## **10.00 INSPECTION**

The inspection may be carried out by the MSEDCL at any stage of manufacture. The successful Tenderer shall grant free access to the MSEDCL's representative at a reasonable time when the work is in progress. Inspection and acceptance of any equipment under this specification by the MSEDCL, shall not relieve the supplier of his obligation of furnishing equipment in accordance with the specification and shall not prevent subsequent rejection if the equipment is found to be defective. The supplier shall keep the MSEDCL informed in advance, about the manufacturing programme so that arrangement can be made for inspection.

**TECHNICAL SPECIFICATIONS OF 11KV, 22KV, 33KV HORN GAP FUSE  
WITH POLYMER INSULATOR**

**11.00 SCHEDULE:**

The tenderer shall fill in the following schedule which form part of tender Specification & offer. If the schedule is not submitted duly filled in with the offer, the offer shall be liable for rejection.

SCHEDULE 'A' – GUARANTEED TECHNICAL PARTICULARS

**TECHNICAL SPECIFICATIONS OF 11KV, 22KV, 33KV HORN GAP FUSE  
WITH POLYMER INSULATOR**

ANNEXURE - A

**Tests on Insulator units**

1. RIV Test (Dry)

The insulator along with complete hardware fittings shall have a radio interference voltage level below 100 micro volts at one MHz when subjected to 50 Hz AC voltage of 10kv, 20kV & 30 kV for 11kV, 22kV & 33kV class insulators respectively under dry condition. The test procedure shall be in accordance with IS:8263 /IEC:437/CISPR 18-2.

2. Brittle Fracture Resistance Test

Brittle fracture test shall be carried out on naked rod along with end fitting by applying “1n HNO<sub>3</sub> acid” (63 g conc. HNO<sub>3</sub> added to 937 g water) to the rod. The rod should be held 80% of SML for the duration of the test. The rod should not fail within the 96-hour test duration. Test arrangement should ensure continuous wetting of the rod with Nitric acid.

3. Recovery of Hydrophobicity & Corona test

The test shall be carried out on 4mm thick samples of 5cm X 7cm.

- (i) The surface of selected samples shall be cleaned with isopropyl alcohol. Allow the surface to dry and spray with water. Record the Hydrophobicity classification in line with STRI guide for Hydrophobicity classification. Dry the sample surface.
- (ii) The sample shall be subjected to mechanical stress by bending the sample over a ground electrode. Corona is continuously generated by applying 12 kV to a needle like electrode placed 1mm above the sample surface. The test shall be done for 100 hrs.
- (iii) Immediately after the corona treatment, spray the surface with water and record the HC classification. Dry the surface and repeat the corona treatment as at clause 2 above. Note HC classification. Repeat the cycle for 1000 hrs. or until an HC of 6 or 7 is obtained. Dry the sample surface.
- (iv) Allow the sample to recover and repeat hydrophobicity measurement at several time intervals. Silicone rubber should recover to HC 1 – HC 2 within 24 to 48 hours, depending on the material and the intensity of the corona treatment.

4. Chemical Composition test for Silicon Content

The content of silicon in the composite polymer shall be evaluated by EDX (Energy Dispersion X- ray) Analysis or Thermo-gravimetric analysis. The test may be carried out at CPRI or any other NABL accredited laboratory.

**TECHNICAL SPECIFICATIONS OF 11KV, 22KV, 33KV HORN GAP FUSE  
WITH POLYMER INSULATOR**

**SCHEDULE – ‘A’  
GUARANTEED TECHNICAL PARTICULARS  
11kV HORN GAP FUSE WITH POLYMER INSULATOR**

Sr. No.	Particulars	MSEDCL Requirement	To be offered by Bidder
1.	Name of Manufacturer	Mfg to give details	Text
2.	Works Address	Mfg to give details	Text
3.	Manufacturers Type	Mfg to give details	Text
4.	Standard according to which the HGF are manufactured	IS 9385-1980 (Part-II) amended upto date	Text
5.	Rated Voltage	12 kV	Text
6.	Rated Frequency	50 Hz	Text
7.	Continuous current Rating	100 Amp	Text
	Lightning Impulse Withstand Voltage (Positive & Negative Polarity)		
a.	Across the Isolating distance	85 kV (Peak)	Text
b.	To Earth & Between Poles	75 kV (Peak)	Text
9.	Power Frequency Withstand Voltage (Dry & Wet)		
a.	Across the Isolating distance	32 kV	Text
b.	To Earth & Between Poles	28 kV	Text
10.	Temperature Rise	Within permissible limit as per IS 9385-1980 (Part-II) amended upto date	Text
11.	Outdoor/Indoor	Outdoor	Text
12.	Type of mounting	Vertical or Horizontal	Text
13.	Contact Clearance	225 mm	Text
14.	Size of Base Channel	75mmx40mmx5mm	Text
15.	Aluminium Strip for HG Fuse	30mmx5mmx425mm	Text
16.	11kV Polymer Pin Insulator		
a.	Applicable Standard	IEC 61109-2008 amended upto date	Text
b.	Make of Pin Insulator	Mfg to give details	Text
c.	Minimum failing load	5 kN	Text
d.	CD of Pin Insulator (min.)	320 mm	Text
e.	Number of Insulators per Pole	2 Nos.	Text
f.	Diameter of FRP Rod	24mm	Text
17.	Total weight of Horn Gap Fuse	Mfg. to give details	Text



**TECHNICAL SPECIFICATIONS OF 11KV, 22KV, 33KV HORN GAP FUSE  
WITH POLYMER INSULATOR**

**SCHEDULE – ‘A’  
GUARANTEED TECHNICAL PARTICULARS  
22kV HORN GAP FUSE WITH POLYMER INSULATOR**

Sr. No.	Particulars	MSEDCL Requirement	To be offered by Bidder
1.	Name of Manufacturer	Mfg to give details	Text
2.	Works Address	Mfg to give details	Text
3.	Manufacturers Type	Mfg to give details	Text
4.	Standard according to which the HGF are manufactured	IS 9385-1980 (Part-II) amended upto date	Text
5.	Rated Voltage	24 kV	Text
6.	Rated Frequency	50 Hz	Text
7.	Continuous current Rating	100 Amp	Text
8.	Lightning Impulse Withstand Voltage (Positive & Negative Polarity)		
a.	Across the Isolating distance	145 kV (Peak)	Text
b.	To Earth & Between Poles	125 kV (Peak)	Text
9.	Power Frequency Withstand Voltage (Dry & Wet)		
a.	Across the Isolating distance	60 kV	Text
b.	To Earth & Between Poles	50 kV	Text
10.	Temperature Rise	Within permissible limit as per IS 9385-1980 (Part-II) amended upto date	Text
11.	Outdoor/Indoor	Outdoor	Text
12.	Type of mounting	Vertical or Horizontal	Text
13.	Contact Clearance	300 mm	Text
14.	Size of Base Channel	75mmx40mmx5mm	Text
15.	Aluminium Strip for HG Fuse	30mmx5mmx425mm	Text
16.	22 kV Polymer Pin Insulator		
a.	Applicable Standard	IEC 61109-2008 amended upto date	Text
b.	Make of Pin Insulator	Mfg to give details	Text
c.	Minimum failing load	10 kN	Text
d.	CD of Pin Insulator (min.)	560 mm	Text
e.	Number of Insulators per Pole	2 Nos.	Text
f.	Diameter of FRP Rod	34mm	Text
17.	Total weight of Horn Gap Fuse	Mfg. to give details	Text

**TECHNICAL SPECIFICATIONS OF 11KV, 22KV, 33KV HORN GAP FUSE  
WITH POLYMER INSULATOR**

**SCHEDULE – ‘A’  
GUARANTEED TECHNICAL PARTICULARS  
33kV HORN GAP FUSE WITH POLYMER INSULATOR**

Sr. No.	Particulars	MSEDCL Requirement	To be offered by Bidder
1.	Name of Manufacturer	Mfg to give details	Text
2.	Works Address	Mfg to give details	Text
3.	Manufacturers Type	Mfg to give details	Text
4.	Standard according to which the HGF are manufactured	IS 9385-1980 (Part-II) amended upto date	Text
5.	Rated Voltage	36 kV	Text
6.	Rated Frequency	50 Hz	Text
7.	Continuous current Rating	100 Amp	Text
8.	Lightning Impulse Withstand Voltage (Positive & Negative Polarity)		
a.	Across the Isolating distance	195 kV (Peak)	Text
b.	To Earth & Between Poles	170 kV (Peak)	Text
9.	Power Frequency Withstand Voltage (Dry & Wet)		
a.	Across the Isolating distance	80 kV	Text
b.	To Earth & Between Poles	70 kV	Text
10.	Temperature Rise	Within permissible limit as per IS 9385-1980 (Part-II) amended upto date	Text
11.	Outdoor/Indoor	Outdoor	Text
12.	Type of mounting	Vertical or Horizontal	Text
13.	Contact Clearance	375 mm	Text
14.	Size of Base Channel	75mmx40mmx5mm	Text
15.	Aluminium Strip for HG Fuse	30mmx5mmx425mm	Text
16.	33 kV Porcelain Pin Insulator		
a.	Applicable Standard	IEC 61109-2008 amended upto date	Text
b.	Make of Pin Insulator	Mfg to give details	Text
c.	Minimum failing load	10 kN	Text
d.	CD of Pin Insulator (min.)	900 mm	Text
e.	Number of Insulators per Pole	2 Nos.	Text
f.	Diameter of FRP Rod	34mm	Text
17.	Total weight of Horn Gap Fuse	Mfg. to give details	Text

3 MOUNTING HOLES OF 15MM DIA.

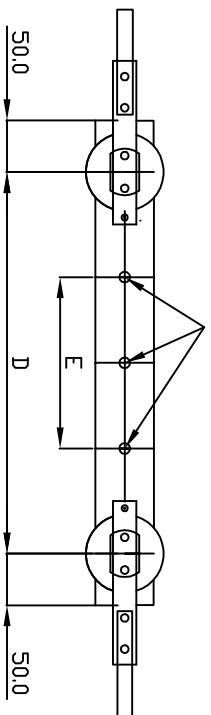

BRASS SCREW WITH WING NUT WITH FLATTENED END

## ELECTRICAL GRADE ONE PIECE, AL. FLAT STRIP

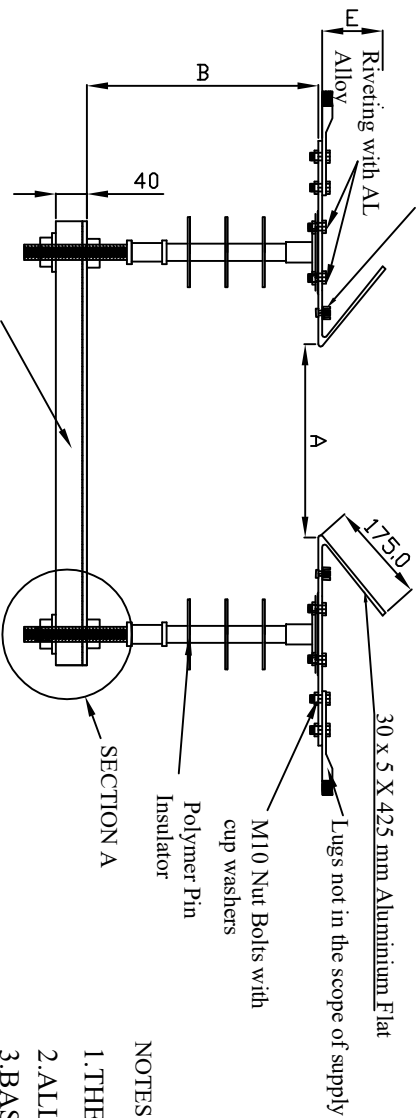
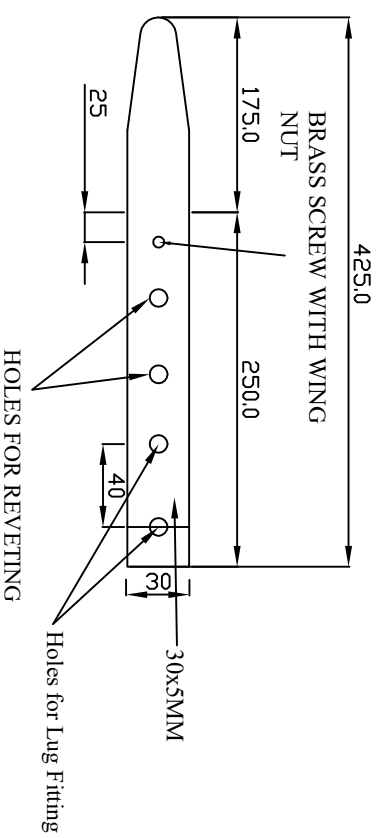

Base Channel MS HDG  
75x40x5mm

SYSTEM VOLTAGE	A MM	B MM	D MM	E MM
11KV	225	325	480	150
22KV	300	500	550	150
33KV	375	700	675	150

NOTES:-

1. THE ALUMINIUM STRIP 30X5MM FOR HG & CONNECTOR
2. ALL NUTS, BOLTS, WASHERS, FLAT, ROD ARE HOT DIP GALVANISED.
3. BASE CHANNEL IS HOT DIP GALVANISED.
4. PIN INSULATOR CONFORMS TO IEC 61109-2008 (AMMENDED UPTO DATE) & SHALL HAVE MINIMUM FAILING LOAD OF 5KN FOR 11KV AND 10KN FOR 22 & 33KV.
5. THE END FITTINGS OF INSULATOR SHALL BE MADE OF SPHEROIDAL GRAPHITE CAST IRON or MALLEABLE CAST IRON or FORGED STEEL or ALUMINIUM ALLOY
6. THE WING NUT SHALL NOT FALL DOWN & THE END OF BOLTS SHOULD BE FLAT ENDED & ARE OF BRASS.
7. ALL DIMENSION ARE IN MM
8. TOLERANCE IS AS PER RELEVANT IS

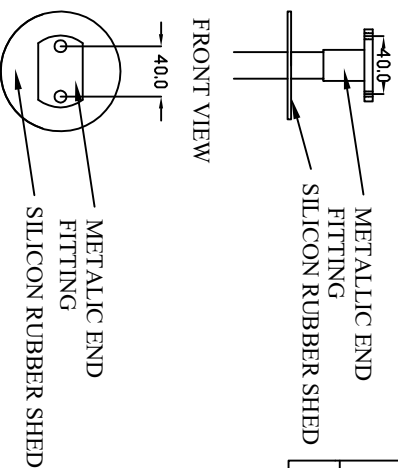

FRONT VIEW

TOP VIEW

PIN INSULATOR FOR TOP  
END FITTING ASSEMBLY

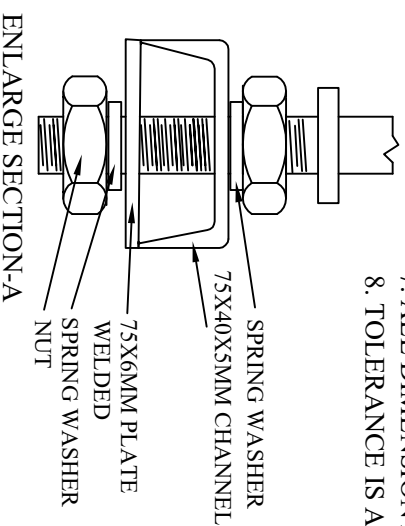

ENLARGE SECTION-A

MSEDCL

TITLE:-  
General Arrangement drawing of  
11KV, 22KV, 33KV Horn Gap  
Fuse with Polymer Pin Insulator

DRG. NO.:- 11/22/33KV HGF- POLYMER