

## Maharashtra State Electricity Distribution Co. Ltd.

Tender Details		01-02-2021 04:55:16
Tender Code	MMD/T-NSC-01/0121	
Tender Type	Works Tender	
Type Of Bid	Two Bid	
Description	Supply, installation and FMS activity for 5 years for LTAC Three Phase 10 - 60 Amps Prepaid Static Energy Meter as per IS: 16444-2015 with Communication module for Agriculture connections under Ag. HVDS Scheme in entire state of Maharashtra	
Estimated Cost (In Lakhs)	7663.73	
Basis of prices	NA	
Tender Validity	NA	
Delivery Requirement (In Months)	NA	
Tender on rate contract basis	NO	
Tender Fee (In INR)	25000	
GST In INR (@18% on Tender Fee: SAC	4500	
Total Tender Fee Amount including GST in INR.	29500	
Contact	Mr Manoj Dhabarde , 8879413602 ,cemmcsedcl@gmail.com	
Pre-Qualifying Req	As per QR Cl. No. 2.4 of Tender Document	
Budget Type	Capex	
Scheme Code	Ag HVDS	
Scheme Name	Scheme not applicable	
Department	Material Management Cell	
Office Type	HO	
Location Type	Corporate Office	
Designation	Executive Engineer(Distribution)	
Pre-Bid Meeting Address	Office of Chief Engineer (MMD), Maharashtra State Electricity Distribution Co. Ltd., Materials Management Department, Plot No. G-9, "Prakashgad" First floor, Prof. Anant Kanekar Marg, Bandra (E), Mumbai – 400 051.	
Bid Opening Address	Office of Chief Engineer (MMD), Maharashtra State Electricity Distribution Co. Ltd., Materials Management Department, Plot No. G-9, "Prakashgad" First floor, Prof. Anant Kanekar Marg, Bandra (E), Mumbai – 400 051.	
Version No	1	
Call for Deviation	NO	
Is Annexure C1 Applicable	NA	
Is Manufacturer Applicable	NO	

Is Trader Applicable	NO
Minimum % of Offered Quantity	NA
Is Power Supplier Applicable	NO
Tender Sale Start Date	01-02-2021 17:30
Tender Sale End Date	22-02-2021 12:00
Bid Start Date	01-02-2021 17:35
Bid End Date	22-02-2021 15:00
Pre-Bid Meeting Date	09-02-2021 12:00
Techno-Commercial Bid opening on	22-02-2021 15:30
Price Bid opening on	Will be declared later
Annexure C1 Opening Date	NA
Winner Selection Date	Will be declared later



**MAHARASHTRA STATE ELECTRICITY  
DISTRIBUTION CO. LTD.**

**Request for Proposal**

Tender for Supply, installation and FMS activity for 5 years for LTAC Three Phase 10 - 60 Amps Prepaid Static Energy Meter as per IS: 16444-2015 with Communication module for Agriculture connections under Ag. HVDS Scheme in entire state of Maharashtra.

**Tender No: MMD/T-NSC-01/0121**

**Estimated Tender Cost: Rs. 76.64 Crores**

CHIEF ENGINEER,  
Maharashtra State Electricity Distribution Co. Ltd.,  
Materials Management Deptt.,  
Plot No. G-9, "Prakashgad" First floor,  
Prof. Anant Kanekar Marg,  
Bandra (E), Mumbai - 400 051.  
E-mail: cemmcsedcl@gmail.com

## 1.0 INTRODUCTION

### 1.1 Overview:

Maharashtra State Electricity Distribution Company Ltd (MSEDCL) has its operations in the North East area of Mumbai and rest of Maharashtra State with a customer base of around 2 Crore 80 Lakhs. MSEDCL expends substantial effort and resources in realizing its mission of 'Ensuring Excellence in Customer Services'.

### 1.2 Objective:

MSEDCL has taken a decision to provide 1,50,000 nos. of Three phase prepaid meters under Ag. HVDS Scheme. These three Phase Prepaid meters are required for New Ag. connections as well as replacement of some of the existing Ag connections released under Ag. HVDS Scheme spread over entire state of Maharashtra..

The main objective is to provide supply and installation of LT AC Three Phase 10-60 A Prepaid Static Energy Meters as per IS: 16444-2015 with communication module and FMS activity viz. Establishment and maintenance of communication between meter and server, Application Server, Communication (Data + SMS), pre-paid metering solutions & Training etc. The Prepaid meter data using communication module shall be transported to HES through WAN.

As per the scope of consumers to be covered, the agencies have to supply the meters to the nearest MSEDCL store as per the Dispatch instructions. For installation at site the store in charge will issue the meters to the agency after acceptable in Random sample testing of the lot supplied. The working manual is attached as Annexure-IX.

These meters are to be installed for 1,50,000 nos. of Ag. consumers spread over entire state of Maharashtra .Meter data of these LT Ag consumers meters to be acquire automatically from the remote for 5 years avoiding any manual intervention, monitor important distribution parameters, use of meter data for accurate billing purposes and generate exceptions and MIS reports for proper planning, monitoring, decision support and taking corrective actions on the business activities by Management. The list of Ag. consumers to be covered is attached as Annexure-XIII.

The above objective is achieved by providing an automatic meter reading (AMR) based data logging LT AC Three Phase 10-60 A Prepaid Static Energy Meters.

## 1.3 Implementation of Prepaid meters in MSEDCL

### 1.3.1 Commissioning:

The commissioning of Prepaid Meters is one time job after installation of these meters in field.

### 1.3.2 Intent of the Project:

The intent of the tender is to select agencies supplying and installing the LT AC Three Phase 10-60 A Prepaid meters along with allied materials for service connections wherever required on Ag. consumer & can implement the solution for Prepaid meter readings in a time bound manner. The prospective bidder shall quote the meter cost, installation charges and FMS Charges per meter for a period of 5 years from the date of installation of meters.

## 2.0 SCOPE OF WORK

### 2.1 Project

The scope of the project covers supply and installation of Meters along with allied materials for service connections, Establishment and maintenance of communication between meter and server, Application Server, Communication (Data + SMS), pre-paid metering solutions & Training etc.

The work involves following activities:

- i. To remove meters from some of the existing Three phase LT Ag consumers released under Ag. HVDS Scheme spread over entire state of Maharashtra & uploading the details of meter including reading at the time of removing the meter. These removed meters are to be credited to MSEDCL office by the agency.
- ii. Providing and fixing 1,50,000 nos. of LTAC Three Phase 10 - 60 Amps Prepaid Static Energy Meter as per IS: 16444-2015 with Communication module as per MSEDCL's technical specifications along with allied materials for service connections wherever required. These Three Phase Prepaid meters are required for New Ag. connections as well as replacement of some of the existing Ag connections released under Ag. HVDS Scheme as and where basis spread over entire state of Maharashtra & communication of the same through Central Server (FMS) for the period of 5 years as specified in technical specification The list of Ag. consumers to be covered is attached as Annexure-XIII..
- iii. Installation of SIM cards (made available under MSEDCL NBSP contract) and establishment of connectivity between meter & central server. SIM cards of service providers such as Vodafone, Airtel and Reliance Jio shall be provided by MSEDCL under NBSP umbrella scheme. The cost of SIM card & recurring monthly charges shall be borne by MSEDCL. However, the bidder has to decide for location wise service provider and inform the service provider wise SIM requirement to MSEDCL .
- iv. Seamless Integration of meters with existing systems / software / solutions of MSEDCL & integration with Data Centre /Disaster Recovery Centre for making the same operational is in the scope of bidder.
- v. Meter Replacement details (Old meter reading final reading, new meter initial reading, date of meter replacement etc.) to be fed by bidder directly to Central Server using MSEDCL New Connection App; mobile app. Required access and training for using the app will be given to successful bidder.

#### 2.1.1 Facility Management Services (FMS) Activities For Prepaid Meters / Communication connectivity scope :

- i. Setting up data connectivity between prepaid meter & central server. SIMs of empanelled service providers will be provided by MSEDCL. Selection of service provider having best network strength at site will be responsibility of agency.
- ii. Ensuring 24\*7 data connectivity between prepaid meter & central server.
- iii. In case of communication failure between Prepaid meter and central server bidder has to resolve issue within 72 hours & establish communication between meter & server. Also bidder shall make alternate arrangements to download the prepaid meter data through optical port, at its own cost. In such cases the bidder should read the meter data through optical port and the downloaded data should be uploaded to prepaid application. Any failure to meet this requirement shall attract penalty as per SLA with bidder for maintenance & support during warranty and FMS periods.
- iv. In case of non-communication due to SIM card issues, agency should resolve SIM issues after reporting to concerned service provider. Escalation matrix of all empanelled service providers will be shared with successful agency.
- v. In case of non-communication due to issues of communication module in meter, agency has to replace such meters/ communication module (in case of pluggable communication module)

- vi. Agency should monitor prepaid engine & web based prepaid application remotely and ensure 24\*7 uptime of these applications.
- vii. The bidder should facilitate the signing of SLA and agreement between bidder and MSEDCL.
- viii. The bidder shall ensure and commit its SLA for maintenance and support during Warrantee and FMS periods of contract.
- ix. MSEDCL has its own in house developed MDAS module. The features of MSEDCL MDA solution are described below:
  - a. The Meter Data Acquisition System can acquire data from various meter make Energy Meters connected through serial communication using in-built/plug-in type GPRS communication module capable of establishing wireless communication with external entities such as Prepaid server, Head End System etc. Two way communication with external entities should be possible.
  - b. The data extraction can be granular (based on type of data e.g. billing, instantaneous, load profile, etc.) and incremental in order to minimize the data volume.
  - c. The scheduling features allows to user to configure the acquisition schedules for a location, set of meters or for the office hierarchy such as division, subdivision.
  - d. The system maintains complete history of metering points, consumer details and can compare data points of the same or different metering points.
  - e. Supports report server integration.
  - f. The system is scalable and integration with other applications of MSEDCL.
- x. The Successful Bidder is supposed to do the necessary seamless integration with MSEDCL's existing Meter Data Acquisition system and legacy systems.

### **2.1.2 Web Based Prepaid Application**

As per the clause no. 11 of Technical specifications.

### **2.2 Variation of Scope:**

MSEDCL will have full-undisputed discretionary rights to add or reduce the scope of work/area of interest as per its requirements and agency will have to comply accordingly. Anytime during the contract period, MSEDCL may modify its business process/workflow as per its requirements and agency will have to comply with it, without any adverse commercial implications. MSEDCL will have full undisputed discretionary rights to continue solution implementation after the tender contract period.

### **2.3 Project Deliverables:**

The project deliverables will include, but are not limited to:

- i. Project plan along with proposed solution document.
- ii. Communication equipment's .
- iii. Technical specification / Data sheet of module details and chipset details
- iv. Software and hardware tools used for network planning, analysis and debugging.
- v. System manual / user manual and data collection software used.
- vi. Web based data collection software should be handed over to MSEDCL along with source code with documentation. Also this software shall be integrated with MSEDCL MDAS application.
- vii. Configuration tool, if any, used for service provider settings / network settings shall be supplied to MSEDCL.

## 2.4 QUALIFYING REQUIREMENTS:-

The Bidder must meet the qualification criteria detailed as under:

- I) Bidder may be either original meter manufacturer or system integrator (AMI solution provider) with authorization of OEM or consortium of meter manufacturer & system integrator. Joint Venture companies can also participate.
- II) Bidder must meet the qualifying requirements of both meter manufacturer & system integrator (AMI solution provider) individually and in case of consortium /Joint Venture collectively by the members of consortium / Joint Venture, except where specifically mentioned.
- III) If the individual bidder is not meter manufacturer then it shall also fulfill all the qualifying requirements of Meter Manufacturer through the OEM, further should be an authorized implementation partner of OEM products proposed in the bid and should possess all the necessary authorizations of the OEM in order to supply, customize, implement and support their OEM solutions.
- IV) The Bidder/ lead bidder (in case of consortium) must be a single entity having at least one permanent establishment of its own office in India ,registered in India under companies Act 1956 or Companies Act 2013, or firm registered with Registrar of firms and societies in India who fulfills the eligibility criteria. The Bidder/members of consortium should not have been blacklisted by *any Ministry of GoI / GoM / state owned electricity distribution utility and still in force.*
- V) The bidder /lead bidder shall be registered on MSEDCL's e-tender website.
- VI) The Members of consortium should have collective turnover of 60% of estimated cost of the tender or Rs. 100.00 Crores whichever is higher at least in any one of the last three financial years, however minimum turnover of System Integrator in any one of last 3 financial years shall be 20 Cr.
- VII) The Lead bidder (in case of a consortium) shall be responsible for all the deliverables under the contract & shall have the authority to conduct all businesses for and on behalf of any and all the parties during the bidding process and, in the event the bidder is awarded the Contract, during contract execution.
- VIII) The Lead bidder (in case of a consortium) shall be bound to MSEDCL for the fulfillment of all the provisions of the entire Contract, while the other member of consortium shall be jointly and severally responsible for their portion of work in accordance with the contract terms.
- IX) The OEM shall have ISO 9001:2008 certifications or shall have CMMI Level 3 (minimum) Certification or equivalent International standard certification.
- X) In case of non-performance (slippage in milestones, scope & quality of work, discipline, etc. as assessed by utility) and / or bankruptcy of any of the consortium member (AMI/AMR etc.), the bidder (Lead member in case of a consortium) shall take necessary remedial action at no additional cost to the project cost already quoted at the time of bidding for the project.

### **(A) Qualifying requirement for meter manufacturer :**

- I) Should be original manufacturers of L.T.A.C. Static Energy Meters.
- II) The turnover in any one of the last three financial years shall be 60% of estimated cost of the tender or Rs. 100.00 Crores whichever is higher.
- III) Shall have supplied minimum 12.5 lakhs static meters during the last three financial years.

- IV) Shall have minimum experience of three years of supply or manufacturing for static energy meters up to the end of the last financial year.
- V) The offers of Indian subsidiary company, whose parent company is located abroad fulfilling the qualifying requirements, shall be considered provided the Indian participant subsidiary company fulfils the minimum experience of three years of supply or manufacturing of static energy meters up to the end of the last financial year. Further, the conditions of turnover (i.e. Rs. 100.00 Crores or 60% of estimated cost of tender whichever is higher) during any one of the last three financial years and supply of minimum quantity of 5 lakhs static energy meters during the last three financial years out of which 2 Lakhs meters shall have been supplied in immediate preceding financial year can be fulfilled by the parent company located abroad on behalf of their Indian subsidiary company. The parent company shall furnish undertaking for accepting responsibility for supplying quality meters as per specifications and execution of the contract on behalf of its India based subsidiary unit who has participated in the tender in Annexure-I.
- VI) In case of offers of Foreign bidders/manufacturers, they shall fulfill Qualifying Requirement as per Sr. No. [I], [II] and [III] above.
- VII) The offer from any one of Indian manufacturing companies which are sister companies of the same group and with the same management having majority of common Directors and share holders shall be considered provided they are jointly fulfilling the Qualifying Requirements as per Sr. No. [I] , [II] and [III] above.
- VIII) Bidder must possess the following certifications at the time of submission of the bid.
  - a) The meter shall bear ISI mark as per IS:16444/2015 amended up to date.
  - b) ISO 9000.
  - c) ISO 14000.Or IEC Certificate
- IX) The participating firm should submit valid NABL accreditation Certification that they have in house National Accreditation Board for Testing and Calibration Laboratories (NABL) Lab for testing of Energy Meters or equivalent International accreditation certification.
- X) The participating firms have to submit ISO 9001:2008 certifications or Capability Maturity Model Integration (CMMI Level - III) certificate or equivalent International standard certification along with offer.
- XI) The participating firms have to submit R & D certification from Department of Science and Industrial Research (DSIR) or equivalent International standard certification along with offer. However, those firms which are not having R & D certification but have applied for R&D Certification, they shall submit this certificate before opening of Commercial Bid (Price Bid) of subject tender. Non submission of Certification before opening of Commercial Bid (Price Bid) from bidders, their offer shall not be considered for further evaluation.

**(B) Qualifying requirement for AMI solution provider:**

- I) The AMI solution provider should have a cumulative turnover of at least Rs. 20 Crores in any one of the last 3 financial years.
- II) AMI solution provider should have successfully executed at least 2 AMI/AMR projects involving an installation of at least 10,000 meters/modems with successful integration with head end system



against the projects from year 2011-12 and onwards. The AMI/AMR project should have been operational for at least 2 years as on date of opening of the bid.

- III) Should have at least 25 employees having work experience of 5 years and have worked in IT Sector in electricity distribution on its payroll as on 31st March 2020.

# Manufacturer's Authorization (To be obtained from OEMs)

Date:  
Tender No.:  
Alternative No.:

To

WHEREAS \_\_\_\_\_

who are official manufacturers of \_\_\_\_\_ having factories at \_\_\_\_\_ do hereby authorize \_\_\_\_\_ to submit a Bid in relation to the Invitation for Bids indicated above, the purpose of which is to provide the following Goods, manufactured by us \_\_\_\_\_ contract and to subsequently negotiate and sign the Contract.

We hereby extend our full guarantee and warranty in accordance with respect to the Goods offered by the above firm in reply to this Invitation for Bids. We also confirm that we are fully aware of the scope of work and have complete knowledge of the terms and conditions of the refereed tender.

Name \_\_\_\_\_

In the capacity of: \_\_\_\_\_

Signed \_\_\_\_\_

Duly authorized to sign the Authorization for and on behalf of \_\_\_\_\_

Date \_\_\_\_\_

## 2.5 TIME OF PERFORMANCE:

- I) Contract period requirement:  
 For supply of meters - 6 month from date of LoA .  
 For installation of meters - 8 month from date of LoA .  
 The 10% of ordered quantity is required to be supply within 2 months from date of LoA & the balance quantity in equated monthly lots within delivery schedule of 4 months.  
 The contract period for ordered quantity will be spread over the contract period of tender in proportion to the quantities quoted by the firms.  
 Time period of contract is 68 months from date of LoA by the employer, which includes survey, removal of existing meters, supply and installation of new Three Phase Prepaid Meters on consumer installations implementation & integration of prepaid solution and five years for FMS activity of above installed three phase meters through MDAS/Central Server.
- II) Further it shall be ensured by the bidder that the supply of Three Phase Prepaid meters, should start after placement of LoA and subsequent activity of installation & readings/ FMS activity shall be started in the immediate subsequent month. The bidder accordingly shall submit their milestones and strictly adhere to it.
- III) The bidder should complete field survey and installation of Three Phase Prepaid Meters in-line with tender specification. No extra time for implementation or extension of contract period is allowed unless specifically agreed to in writing by the EMPLOYER.

## 2.6 ACCEPTANCE OF SUPPLIES/INSPECTION:

- I) The supplier shall normally offer at a time, the entire quantity required to be delivered every month as per the delivery schedule indicated at Annexure 'B' of A/T for the purpose of inspection by the Purchaser. However, in exceptional circumstances, the supplier may be allowed to offer quantity at a time not less than 50% of the quantity required to be delivered every month.
- II) Materials shall be inspected by the Purchaser's Executive Engineer/or the representative authorized by the Purchaser before dispatch. An intimation in the prescribed proforma about the date on which materials shall be ready for inspection, indicating approximate quantity, shall have to be given to the Chief Engineer (MMD), Maharashtra State Electricity Distribution Co. Ltd., 'Prakashgad'. 1st floor, Station Road, Bandra (East), Mumbai - 400 051, in advance failing which, the supplier shall be responsible for delay in delivery on account of inspection. On receipt of such intimation, the materials shall be inspected within 20 days. The materials shall be dispatched only after inspection and approval of same by the Inspector. The inspection approval letter shall be valid for a period of 30 days from the date of issue of letter to enable the supplier pack the material and arrange transportation thereof so that material should be reached at the respective consignee within 30 days from the date of inspection approval letter. After this period of 30 days, the validity of this inspection approval letter will lapse. If the supplier fails to dispatch or the material is not reached within 30 days to respective consignees, the approval of purchaser is to be sought by the supplier for revalidation of inspection approval letter.

- III) The supplier shall notify the names of the consignees to whom the inspected lot would be despatched. The Inspector shall intimate change in destination, if any, at the time of inspection approval and accordingly the material shall be despatched. The supplier shall get the copies of inspection approval letter together with witness certificate duly signed by the concerned Inspecting Officer IN BLUE INK only and also mention reference or inspection approval letter on the challan / invoice, failing which any delay occurred in getting the S.R. Notes from the consignees would be solely to supplier's account.
- IV) Factory address, from which the bidder has to supply the material, shall be as indicated in the latest approved on line vendor registration form on e-tendering through which the bidder has submitted the offer.
- V) In the event, during the inspection by the Purchaser's Inspecting Officer, if it is observed that the quantity actually offered for inspection is less than the quantity indicated for inspection in the inspection call, the Purchaser shall be entitled to recover from the supplier, the actual expenses incurred for arranging the inspection, and the supplier shall not dispute the amount to be recovered.
- VI) The supplier shall submit the test certificates/reports from any approved laboratory or the laboratory of his own for the respective quantity of material, before dispatch. The material shall not be dispatched unless and until the test certificates are approved by the Purchaser.
- VII) All the necessary help shall be extended by the supplier to the authorized representative of the Purchaser to carry out testing of equipment/materials.

### 2.7 MILE STONES :To be submitted along with techno-commercial offer.

Milestone for Three Phase Prepaid Meters	Qty. in Nos.	Timelines (Month wise)	% age penalty on Price
1	2	3	4
Supply	To be filled by the bidder	As per Cl. 2.5 of RFP	After the completion of timeline, LD @ 0.5% of committed lot value per week or part-thereof with maximum 10% of the contract value may be levied from the bill of the contractor
Installation	To be filled by the bidder	As per Cl. 2.5 of RFP	
FMS / Meter reading through AMR	To be filled by the bidder	Immediate subsequent month of installation of each meter.	

- 2.8 The minimum quantity to be offered by the bidder shall be 20% of the tender quantity failing which the offer is liable for rejection. The L-1 will be arrived as per package cost.

### 3.0 BIDDING PROCEDURE AND INSTRUCTION TO BIDDERS

#### 3.1 ELIGIBILITY TO BID

The bidding process will be open to any agency who satisfies the **Qualifying requirement as per clause no 2.4.**

1. Bidder is eligible to submit only one bid.
2. Bids will be accepted by MSEDCL for those Bidders who have confirmed for their participation as mentioned in the Tender.

The bidder will be responsible for submitting the proposal and it will be the single point-of-contact for all information and clarification throughout the Procurement Process.

#### 3.2 To be qualified for award of Contract, bidder shall also submit:

- I) Copies of original documents defining the constitution or legal status, place of registration and principal place of business for the bidder; and
- II) A written power of attorney / letter of authorization authorizing the signatory of the bid to commit the bidder; and Audited annual accounts including balance sheets and other financial statements for any of the three (3) consecutive financial years (FY16-17, FY17-18, FY18-19 & FY19-20);and
- III) Authority to seek references from the bidder's Bankers along with details of the Banks;
- IV) Proposals regarding work methods, scheduling and resourcing which shall be provided in sufficient detail to confirm the bidder's capability to complete the work in accordance with scope of work and the time for completion, including qualifications and experience of personnel proposed for the contract.
- V) The bidder shall submit the declaration along with the bid as below.
  - a. *The business dealings with the agency have not been debarred by any Ministry of GoI / GoM/ state owned electricity distribution utility and still in force.*
  - b. *The Directors, Proprietors, Partners, Employee(s) or owner of the agency have not been either jointly or severally guilty of malpractices in relation to its business dealings with the Government or MSEDCL during the last five years.*

#### 3.3 Overview of bidding process

The Bidding Process would comprise of following sequential steps. MSEDCL reserves the right to reject all or any of the Bidders or Bids or discontinue or cancel the bidding process without assigning any reason whatsoever. These include the following:

1. It will be 'Single Bid Two Stage' tender process.
2. The key features of the tender in the form of Invitation for Bid will be released by MSEDCL on the MSEDCL website <http://www.mahadiscom.in> on tender release date.
3. Entire bidding document shall be available only in electronic format (soft copy) and is to be downloaded from Employer's website <http://www.mahadiscom.in> (or directly from URL <https://etender.mahadiscom.in/eatApp/>) from tender release date onwards. It shall be the bidder's responsibility to ensure that the entire bid document is downloaded from the requisite website. No hard copy of tender document will be provided. All the subsequent instructions/corrigendum to the

bidding document etc. shall also be available on the website mentioned above.

4. To clarify any points on the tender, MSEDCL will organize a Pre-Bid Meeting, wherein all the interested bidders can participate. This meeting is not mandatory for the bidders.
5. The response to the Tender has to be submitted by the bidder who will be designated as a Bidder for the purpose of this Tender. The entire bidding process will be e-Tendering process. Bidder has to submit the documents through E-tender application in soft copy i.e. PDF as well as word/xls format
6. MSEDCL will open the Technical & Commercial Bid and the technically qualified Bidders will be informed based on the evaluation.
7. The technically qualified bidders may be asked to present their technical capabilities either by onsite presentation at MSEDCL or demonstration of Proof of Concept before the price bid is opened.
8. Technically Qualified Bidder's Price Bid will be taken forward for comparison & the Lowest Price Bid will be declared as the Bid Winner.
9. In case the bidder is successful, the contract agreement will be signed between MSEDCL and the Bidder.

## 4. CONTENTS OF THE BID

### Tender Fee & Bid Security (EMD)

#### a) Tender Fee

A Non-Refundable Tender Fee of **Rs. 25,000 (Rupees Twenty Five Thousand Only)** plus 18% Goods and service tax (GST) shall be furnished only by way online payment through e-tendering website.

#### b) Bid Security (EMD)

The bidder should pay the Earnest Money @ 0.50% (Half Percent) value of the offered quantity of Tender in the form of BG as per the Annexure – IV (A) enclosed with tender documents having validity of 120 days from opening of tender. Interest shall not be allowed on EMD.

However, bidders from the following categories are exempted from payment of earnest money deposit.

- 1) All Government and semi Government institutions under Govt. of Maharashtra and Zilla Parishad in Maharashtra and fully owned undertaking of any State Govt. and Govt. of India only for the items manufactured by such institutions.
- 2) Micro and Small Enterprises registered under Micro, Small and Medium Enterprises Development Act-2006 only for the items mentioned in their permanent registration certificate at the time of vendor registration.
- 3) The bidder registered with N.S.I.C. and those who have attached valid N.S.I.C. Registration Certificate for the items mentioned in their permanent registration certificate at the time of vendor registration.

The benefits mentioned in (1) to (3) above shall be available only to those items approved during the registration process and subsequent updates in registration up to the date of submission of this tender.

Exempted bidders should upload a latest valid certificate issued by any approved body of 'Ministry of Small & Medium Enterprises' (MSME) such as 'National Small Industries Corporation' (NSIC) or 'District Industries Centre' (DIC) for EMD exemption.

- i. Bidder should upload the Scanned copy along with the Bid documents on E-Tender website. However, Bidder will have to submit the Bank Guarantee to the MSEDCL on or before the last date of Submission of Tender.
- ii. Any tender not accompanied by the requisite Earnest Money Deposit (EMD) shall be rejected and shall not be considered for evaluation.
- iii. The bid security of the successful bidder shall be returned after (i) acceptance of LOA by the bidder and (ii) the contract performance security is furnished by the bidder and accepted by the owner.
- iv. Unsuccessful bidder's bid security will be discharged/returned as promptly as possible.
- v. The bid security may be forfeited:
  - (a) If the bidder withdraws its bid, except that written notice of the withdrawal of bid is received by the employer prior to the deadline for submission of bids; or
  - (b) If the bidder does not accept the correction of its bid price, pursuant to Tender Conditions; or
  - (c) if the bidder is determined, at any time prior to award of contract, to have engaged in corrupt, malpractice or fraudulent practices in competing for the contract; or
  - (d) In the case of a successful bidder, if it fails within the specified time limit to:
    - (i) Sign the Contract Agreement, or
    - (ii) Furnish the required contract performance security

- vi. No interest shall be payable by the owner on the above bid security.
- vii. MSEDCL will not entertain any request for adjusting the EMD from the bidder's due/running bills or from the EMD/Security Deposit of any other tender participated by the bidder.
- viii. Offers received without Tender Fee and EMD are liable for rejection.

**4.1 Confirmation on submission of documents& Mandatory requirements**

A summary sheet confirming whether all documents/requirements have been met along with page reference to where in the Bid have compliance to these requirements which have been described / included should be furnished by the bidder (Refer Annexure - X):

**4.2 Technical and Commercial Bid**

This part of the bid consists of all the documents/ requirements except the price bid schedule Annexure – VI.

Note: submitting the bid to the e-tender web site confirms compliance of all the commercial conditions by the bidder.

**4.3 Price Bid**

The Price Bid should be submitted as per (Annexure – VI).

The bid shall contain no erasures or overwriting, except to correct errors made by the Bidder, in which case the person or persons signing the bid shall initial such corrections. Price should be quoted in number & words. In case of discrepancy and or difference in the value between the Quoted price in Number and as expressed in words, lower of the two/beneficial to MSEDCL shall be considered .



## 5.0 GENERAL BID INSTRUCTIONS

### 5.1.1 Intent of Bid Specification

The intent of this bid specification is to enter into single contract covering completely the scope of work specified in the accompanied specification forming completely coordinated and engineered package, all in accordance with the specifications as detailed out in the various sections of this bid document. MSEDCL in order to implement the project will be entering into single responsibility contract with the successful bidder. Bids not covering the entire scope of work as detailed in the Bid Specification will be treated as non-responsive and hence rejected.

**However, MSEDCL reserves the right to split the scope in any number of contracts or may award contract for partial scope of work.**

### 5.1.2 Conflict of Interest

- i. Each Bidder shall submit only **one bid** for each contract (Tender). A bidder who submits or participates in more than one bid for same tender will be disqualified.
- ii. All bidders found to be in conflict of interest shall be disqualified. A bidder may be considered to have a conflict of interest with one or more parties in a bidding process if they:
  - a. Have controlling shareholders in common; or
  - a. Receive or have received any direct or indirect subsidy from any of them; or
  - b. have the same legal representative for purposes of a bid; or
  - c. have a relationship with each other, directly or through common third parties, that puts them in a position to have access to information about or influence on a bid of another bidder, or influence the decisions of the Employer regarding the bidding process; or
  - d. submit more than one bid for any particular contract package in the bidding process. This however does not limit the participation of subcontractors in more than one bid or as bidders in one bid and subcontractors in other bids simultaneously; or
  - e. participated as a consultant in preparing the design or technical specifications of the goods and related services or works that are the subject of a bid.

For verification of conflict of interest, a copy of Articles of Association & Memorandum of Association in case of company & in case of partnership firm, a copy of partnership deed is required to be submitted by bidders along with bid.

### 5.1.3 Compliance to MSEDCL Ethical Standards

MSEDCL attaches top most priority to adherence to the highest ethical standards in all its transactions and expects the same from all entities it enters into any relationship with.

Accordingly, it expects every Bidder to observe the highest standard of ethics and integrity during the bidding process and if successful, during all stages of the project. If a bidder is found to have indulged in any corrupt or fraudulent practice or in any practice which is not in conformity with the highest ethical standards, then the bid will stand rejected. In such a case, MSEDCL may even go to the extent of black-listing the bidder and barring it from responding to any future enquiries / tenders floated by it.

To ensure uniformity in understanding of corrupt and fraudulent practices between MSEDCL and the bidders, the same has been defined below:

- a) The term 'corrupt practice' means behavior on the part of officials in the public or private sectors by

which they improperly and unlawfully enrich themselves and/or those close to them, or induce others to do so, by misusing the position in which they are placed, and it includes the offering, giving, receiving or soliciting of anything of value to influence the action of any such official in the procurement process or in contract execution; and

- b) The term 'fraudulent practice' means a misrepresentation of facts in order to influence procurement process or the execution of a contract to the detriment of the Employer, and includes collusive practice among bidders (prior to or after bid submission) designed to establish bid prices at artificial non-competitive levels and to deprive the Employer of the benefits of free and open competition.
- c) By signing the Bid Forwarding Letter, the Bidder represents that for the software & services it supplies, it is the owner of the Intellectual Property Rights. Willful misrepresentation of these facts shall be considered a fraudulent practice without prejudice to other remedies that the Purchaser may take.

#### **5.1.4 Important Notes**

The Bidder shall note the following:

- i. Bid documents are not transferable.
- ii. Not more than one bid for the work shall be submitted by one Bidder or one firm of Bidders.
- iii. If the Bidder deliberately gives wrong information in his bid to create circumstances for the acceptance of its bid, the Owner reserves the right to reject such bid and/or cancel the order if placed.
- iv. Bid documents submitted by the Bidder shall become the property of the Owner and the Owner shall have no obligation to return the same to the Bidder.
- v. Bid must cover the entire scope of work (as a full package) as specified in this tender document.
- vi. Bid covering partial scope of work shall not be acceptable.

#### **5.1.5 Bidder to inform himself fully:**

- i. The Bidder shall make independent enquiry and satisfy himself as to all the required information, inputs, conditions and circumstances and factors which may have any effect on its bid price and also on the execution of work covered under these specifications and documents. In assessing the bid it is deemed that the Bidder has inspected and examined the site conditions and its surroundings, examined the laws and regulations in force in India, the transportation facilities available, the conditions of roads, bridges, ports, etc. for unloading and/or transporting heavy pieces of material and to have based its equipment size and fixed its price taking into account all such relevant conditions and also the risks, contingencies and other circumstances which may influence or affect the execution of the works as specified in these bid specification.
- ii. In their own interest, the Bidders are requested to familiarize themselves with the Income Tax Act, the Companies Act, the Customs Act and all other related acts and laws prevalent in India. The Owner shall not entertain any request for clarifications from the Bidders regarding such local laws and the conditions. However, the owner shall direct the bidder from where to obtain such assistance provided the request for such assistance is received well in advance. However, non-receipt of such information shall not be a reason for the bidder to request for extension in opening date of the bid. The Bidder shall understand and agree that before submission of its bid all such factors, as generally brought out above, have been fully investigated and considered while submitting the bid. No claim for financial adjustment to the contract awarded under this specification and documents shall be entertained by the owner. The Owner shall also not permit any change in time schedule or any

financial adjustment arising thereof which are based on lack of clear information for such site conditions, laws and regulations and other related information and/or its effect on the price quoted in the bid.

- iii. Availability of Acts & Regulations: The various acts and regulations referred in these documents are normally available for sale on the following address:

Deputy controller, Public Department, Govt. of India, New Delhi, 110006, INDIA

OR

With leading authorized booksellers

#### **5.1.6 Interpretation of Bid Documents**

If any is in doubt as to the true meaning of any part of the bid document or scope of work to be executed, he shall at once submit a written request in English language for clarification or interpretation of the doubt in question. Such request should reach the owner not later than 4 days prior to the date set for submission of the bids.

This written request shall be submitted in triplicate to MSEDCL on the following address:

Chief Engineer (MMD)

Maharashtra State Electricity Distribution Co. Ltd. "Prakashgad",  
First Floor, Prof. Anant Kanekar Marg, Station Road, Bandra (East),  
Mumbai 400 051 (INDIA)

Appropriate interpretation shall be given in the form of a supplementary notice which will be updated on the website <http://www.mahadiscom.in>. MSEDCL shall respond to any request for clarification of the Bid Documents, which it receives not later than 4 days (four) prior to the deadline for submission of bids prescribed by MSEDCL. No oral or other interpretation shall be considered as binding on MSEDCL.

#### **5.1.7 Amendment of Bidding Documents**

- i. At any time prior to the deadline for submission of bids, the Owner may, for any reason, whether at its own initiative or in response to a clarification requested by a prospective Bidder, modify the bidding documents by amendment.
- ii. The amendment shall be published on the website [www.mahadiscom.in](http://www.mahadiscom.in) and shall be binding on the bidders.
- iii. In order to afford prospective Bidders reasonable time in which to take the amendment into account in preparing their bids, the Owner may, at its discretion, extend the deadline for the submission of bids.

#### **5.1.8 Cost Incurred in Responding to Tender**

MSEDCL will not be responsible or liable for any costs being incurred by individual Bidders in preparing their response to this Tender nor will it be under any obligation to reimburse the same or any part thereof to any Bidder. Each Bidder must bear all costs being incurred by it in responding to this Tender. MSEDCL will also not be responsible for providing any facility or infrastructure to any bidder to facilitate its preparation of its bid.

#### **5.1.9 Language, Font Size etc.**

The bid must be prepared in English language only. All supporting documents submitted as a part of bid must be in English language. Further, all communication with respect to the bid including any accompanying document, must be in English language only. Clarifications sought on the Tender Document must also be in English. While the Bidders are free to submit their response in color, the text in both the original and the copies of the Bid must be black in color, font of size not less than 10.

### 5.1.10 Bid Validity Period

All bids, not rejected for any other reason, will remain valid for a period of 180 days after the date of opening of the technical bid prescribed in the Tender Document or as communicated by MSEDCL. MSEDCL reserves the right to reject a bid which is not valid for the prescribed period of 180 days as non-responsive, without any explanation.

### 5.1.11 Extension of Period of Bid Validity

In exceptional circumstances, MSEDCL may request all the Bidders consent to an extension of the period of validity of their respective bid. The request and the response thereto will be made in writing. Extension of validity period by the Bidder must be unconditional. The bid EMD provided in the form of BG will also have to be accordingly extended. A Bidder will have the right to refuse the request without forfeiting the bid security. A Bidder granting the request will not be permitted to modify his bid.

### 5.1.12 Date for Submission of the Bid

#### a) Deadline for Submission of Bid

The tender is to be submitted online on or before the due date and time for submission of the bid on the MSEDCL e-tendering website. It is advisable to submit the digitally signed bids sufficiently in advance of due date and time so as to avoid last minute trafficking at server. The prospective bidder should be well aware about the online submission of the bid. Any complaint for delay in submission of the bid due to any technical reason will not be entertained.

MSEDCL reserves the right to reject any or all tenders at our discretion without assigning any reason whatsoever.

#### b) Extension of Bid Submission deadline

MSEDCL may, at its sole discretion, decide to extend this deadline for submission of Bids. In such a case, all rights and obligations of MSEDCL and Bidders previously subject to the deadline will thereafter be subject to the new deadline.

#### c) Bids Received Late

As this is e-Tendering Process, the bidder will not be able to upload their bids after the expiry of due date & Time. Any bid received by MSEDCL after the expiry of the specified deadline for submission of bids will be considered as rejected. The Bidders must take all responsibility of submitting the Bids within the prescribed deadline. MSEDCL will not accept any excuse of non-receipt / non-delivery/non-uploading of the Bids.

## 5.2 EVALUATION OF BID/AWARD OF CONTRACT

### 5.2.1 Opening of Bids

MSEDCL shall open the bids at its office located at the address mentioned below:

Chief Engineer (MMD)  
Maharashtra State Electricity Distribution Co. Ltd. "Prakashgad",  
First Floor, Prof. Anant Kanekar Marg, Station Road, Bandra (East),  
Mumbai 400 051 (INDIA)

If any change is there in address the same will be informed to bidder well in advance. Bids received before the dead line of the submission of the bid will be opened on the date and time of opening as indicated in Invitation for Bid. Bidder may view the Bid Opening Online on the e-Tendering Website. Bidders wishing to be present at the time of such opening may send their duly authorized

representative. Maximum of 2 persons per bidder shall attend. Their signatures shall be obtained in a register evidencing their presence at the time of opening & certifying that all bids submitted were opened.

The bids shall be opened in the following sequence:

1. The Tender Fee & EMD is verified first. The bids of those bidders who have not paid the Tender fee or EMD will not be opened and evaluated further.
2. The Technical bid will be opened online on e-tendering website on due date.
3. Price Bid will be opened in online on e-tendering website after completion of the Evaluation process of Technical Bid and the date & time will be informed to the technically qualified bidders in advance.

During the process of technical evaluation, MSEDCL may require the technical presentation from the bidders which would also be the part of evaluation. If the MSEDCL is not satisfied with the proposed solution of the Bidder, then MSEDCL reserves the unconditional & undisputed rights to disqualify the Bidder from Tendering Process.

The purchaser will open the Price Bids (as defined in Tender Clause) of only those Bidders who qualify in technical bid evaluation. The date, time and place for opening the Price Bids will be communicated to the technically qualified bidders. The Bidders may attend the opening or view the Bid Opening Online on the e-Tendering Website.

Bids or modifications thereto may be rejected if they are not addressed as prescribed in the Tender Document. Bids may be rejected outright if it is not accompanied by the prescribed Bid security. Bids rejected during the bid opening phase will not be considered for further evaluation.

MSEDCL may at its sole discretion, seek clarification from the bidders to assist in the evaluation, comparison and an examination of bids. The request for clarification and the response will be in writing. If the response to the clarification is not received before the expiration of deadline prescribed in the request, MSEDCL reserves the right to make its own reasonable assumptions at the risk and cost of the Bidder.

### **5.2.2 Deviations**

No deviation to this tender document is allowed. The bidder has to submit the Annexure – VII ‘**No Deviation Form**’.

### **5.2.3 Alternative Offer**

No alternative offer will be accepted.

### **5.2.4 Preliminary Examination of Bids**

The Purchaser will examine the bids to determine whether they are complete, whether any computational errors have been made, whether required securities (EMD amount) have been furnished, whether the documents have been properly signed, and whether the bids are generally in order. The Purchaser will ensure that each bid is from an eligible Bidder.

Arithmetical errors will be rectified on the following basis.

If there is a discrepancy between the unit price and the total price, which is obtained by multiplying the unit price and quantity, or between subtotals and the total price, the unit or subtotal price shall prevail, and the total price shall be corrected.

If there is a discrepancy between words and figures, lower of the two/beneficial to the MSEDCL shall be

considered. If a Bidder does not accept the correction of errors, its bid will be rejected and its bid security (EMD) may be forfeited.

The Purchaser may waive any minor nonconformity, or irregularity in a bid that does not constitute a material deviation, provided such waiver does not prejudice or affect the relative ranking of any Bidder.

Prior to the detailed evaluation, the Purchaser will determine whether each bid is complete, and is substantially responsive to the Bidding Documents. For the purposes of this determination, a substantially responsive bid is one that conforms to all the terms, conditions, and specifications of the Bidding Documents without material deviations, exceptions, objections, conditionality or reservations. A material deviation, exception, objection, conditionality, or reservation is:

1. One that limits in any substantial way the scope, schedule, quality, or performance of the desired SUPPLY, INSTALLATION & FMS ACTIVITY FOR THREE PHASE PREPAID METER; or
2. One that limits, in any substantial way that is inconsistent with the Bidding Documents, the Purchaser rights or the successful Bidder's obligations under the Contract; and
3. Acceptance of which would unfairly affect the competitive position of other Bidders who have submitted substantially responsive bids.

If a bid is not substantially responsive, it will be rejected by the Purchaser and may not subsequently be made responsive by the Bidder by correction of the nonconformity. The Purchaser's determination of bid responsiveness will be based only on the contents of the bid submitted.

### **5.2.5 Evaluation and Comparison of Bids**

The evaluation of responsive bids shall be done in 2 stages:

#### **a) STAGE-I: RESPONSE TO QUALIFYING REQUIREMENTS**

These are mandatory requirements to be met by the Bidder. Only those bidders who meet all the mandatory requirements as provided in this document shall be considered for stage II evaluation.

#### **b) STAGE – II: EVALUATION OF THE PRICE BID**

Bidders who qualify in the Stage I of evaluation will be considered for stage II evaluation and Price Bids will be opened only for these bidders.

The lowest bid (L-1) will be arrived by considering the package cost of (A)+(B) of Annexure VI and the bidder whose bid is lowest in the reverse bid, will be considered as successful bidder L-1 bidder i.e. L-1 will be arrived as per package cost. All bidders who have qualified in Stage II evaluation and have quoted within range of 5% or above 5% in comparison with the lowest rate may be asked to match the lowest (L1) rate.

After matching with L-1 rate, matching bidders may be awarded remaining quantity /towns at MSEDCLs discretion in order to fulfil the scope of tender.

### **5.2.6 Contacting the Purchaser**

- i. From the time of bid opening to the time of Contract award, if any Bidder wishes to contact the Purchaser on any matter related to the bid, he shall do so in writing.
- ii. If a Bidder tries to influence the Purchaser directly or otherwise, interfere in the bid evaluation process and the Contract award decision, his bid will be rejected.

### **5.2.7 Purchaser's Right to Accept or Reject Any or All Bids**

- i. The Purchaser reserves the right to accept or reject any bid or to annul the bidding process and reject all bids at any time prior to Contract award, without thereby incurring any liability to the Bidders.
- ii. The Purchaser reserves the right to negotiate with the Bidder who becomes eligible for award of the contract as per Tender conditions.

- iii. MSEDCL reserves the right to reject any or all the price bids or Tender at its own discretion without assigning any reason whatsoever.

### **5.2.8 Notification of Award**

- i. Notwithstanding anything contained in this document, MSEDCL reserves the right to accept or reject any bid, and to annul the bidding process and reject all bids, at any time prior to award of contract, without thereby incurring any liability to the affected Bidder or Bidders or any obligation to inform the affected Bidder or Bidders the grounds for the MSEDCL's action.
- ii. Subject to above clause, the owner shall award the contract to the successful bidder whose bid has been determined to be substantially responsive and has been determined as the lowest evaluated bid provided further that the bidder is assessed to be qualified to satisfactorily perform the contract.
- iii. Notification of award of contract shall be made in writing through a 'Notice of Award', i.e. Letter of Award to the successful Bidder. This letter of award may be in writing by registered letter or by cable or FAX, to be confirmed in writing by registered letter or courier service or by speed post that its bid has been accepted.
- iv. Till such time the formal contract is signed, the letter of award issued by the owner to the successful bidder and its acceptance by the bidder shall be construed as a contract document and conditions of contract contained in these documents shall become applicable.

### **5.2.9 Signing Of Contract**

- i. The successful bidder after submission of contract performance guarantee and its acceptance by the owner shall have to sign contract agreement with the Owner within fourteen (14) calendar days from the date of Letter of Award. This agreement shall be signed at the office of the owner in Mumbai on a date and time to be jointly decided.
- ii. The contractor shall send one copy of the final draft agreement to the Owner for his scrutiny and approval within fourteen days (14) of issue of letter of award by the Owner. The contractor shall sign the Form of Contract Agreement on a Rs. 100/- Stamp Paper (non-judicial) issued in Maharashtra and returns it to Owner.
- iii. The Contractor shall provide, before signing of the contract, appropriate power of Attorney and other requisite materials. The contractor shall provide free of cost to the Owner all the engineering data, drawings and descriptive materials submitted with the Bid, in at least six (6) copies to form a part of the contract, immediately after issue of Letter of Award accepting the bid.
- iv. All charges for preparing the contract documents including legal fee, stamp fee etc. shall be borne by the successful Bidder. The contract shall be signed in two original. One to be retained by the owner and one by the bidder. After signing of the contract, the contractor shall furnish to the owner 3 true copies of the signed contract agreement duly bound.
- v. If the successful Bidder fails to sign the contract, the same shall constitute sufficient ground for the annulment of the award of work and also the forfeiture of contract performance guarantee/security, in which event the owner may make the award to the next lowest evaluated responsive bidder or call for new bids.
- vi. All the conditions given in this document shall form the part of the contract. Based on the information submitted by the bidder in response to the instruction to bidder additional clauses may also have to be incorporated and shall be mutually agreed to.

### 5.2.10 Contract Performance Security

- i. The successful bidder shall provide to the owner within fourteen (14) days of issue of letter of intent, the contract performance guarantee as per the provisions of the clause mentioned in this document.
- ii. The contract performance security shall be denominated solely in Indian Rupees, and shall be in the form of an unconditional and irrevocable Bank Guarantee issued by a Nationalized or Scheduled Bank.

### 5.3 Check List

- i. The bidders are requested to go through carefully the instructions for preparation of their bids. Conditions elaborated in “General Conditions of Contract” and “Special Conditions of the Contract” may be borne in mind while bid preparation. The bid shall fully meet the technical requirement specified in this tender document.
- ii. The bidders may depute their representative to visit the site to get any additional information and to check the site conditions personally.
- iii. The bidder may submit additional information, which in his opinion shall help the owner to evaluate the bid. Bidder shall use continuation sheets wherever necessary.
- iv. The Bidders are requested to duly fill in the check list enclosed with Bid (Annexure – X). This check list gives only certain important items, to facilitate the bidder to make sure that the necessary data/information is provided by the Bidder in its proposal. This, however, does not relieve the bidder of its responsibility to make sure that his proposal is otherwise complete in all respects.

#### 5.3.1. Bid Data Sheet

1. The Chief Engineer Material Management Department (MMD), on behalf of Maharashtra State Electricity Distribution Company Limited (the Employer), hereby invites sealed bids from eligible bidders.
2. Entire bidding document is available online on <http://works.mahadiscom.in/eTender/etender> as per date indicated below. Any changes in the Bid Schedule, corrigendum etc. shall also be notified via MSEDCL's website. Prospective bidders are therefore requested to regularly check the website for any updates.
3. **Tender Cost: Rs. 76.64 Crores**
4. **Tender Fee:** Rs 25,000/-+ 18% GST  
The bidder should submit non-refundable Bid Fee of Rs 25,000/-+ 18% GST paid through online payment only, prior to the dead line for submission of bids as per the procedure led by the MSEDCL.
5. **Bid Security:**  
The bid must be accompanied with Bid Security for an amount equal to 0.5% of offered quantity for covering the entire scope of work. The bid security shall be denominated in Indian Rupees only.

**THE CHIEF ENGINEER**  
**(Material Management Dept.)**  
**“Prakashgad” First floor, A.K.Marg,**  
**Bandra(E),Mumbai-400051.**  
**E-mail- cemmcsedcl@gmail.com, cemmcsedcl@mahadiscom.in**



## 6. GENERAL CONDITIONS OF CONTRACT

### 6.1 DEFINITIONS

Definitions: In the contract (as hereinafter defined) the following words and expressions shall have meaning hereby assigned to them except where the context otherwise requires.

- i. "EMPLOYER" or "Owner" or "Purchaser" or "Principal" or "MSEDCL" means Maharashtra State Electricity Company Limited having its Registered Office at Prakashgad, Bandra (East), Mumbai 400051 and includes Employer's representatives or successors or assigns. Employer's representatives include "Project Manager".
- ii. "Project Manager" or "Project Coordinator" means the person appointed by MSEDCL in the manner provided in Tender to perform the duties delegated by MSEDCL.
- iii. "Manager" means any assistant of the Project Manager or any other employee or agent appointed from time to time by the EMPLOYER or the Project Manager to perform the duties related to this contract.
- iv. 'Site' shall mean the locations and places wherever business activities are conducted by the EMPLOYER.
- v. "Contractor" or "Supplier" or "Vendor" or "Bidder" or "SUPPLY, INSTALLATION& FMS ACTIVITY FOR PREPAID METER Bidder" or "System Integrator" (SI) shall mean whose tender has been accepted and shall include his/her/its/their heirs, executors, administrators, legal representatives/ successors/assigns and his/her/its/their Indian Agents approved by the EMPLOYER. SI/Bidder can be a company or a corporation and is the agency who provides all necessary services for the successful implementation of the project deliverables. SI/Bidder must be a single entity. No Consortium shall be allowed.
- vi. "Party" means the Owner or the Vendor, as the case may be and parties mean both of them.
- vii. "Successful Bidder" Successful Bidder means, the bidders whose bid has been accepted meeting MSEDCL's requirement in all respects and stands Lowest among acceptable bids.
- viii. "Contract" or "Work Contract" or "Work Order" means invitation to tender, instructions to Bidders, tender with all the enclosures thereto, articles of agreement, General conditions of Contract, Special conditions of Contract, specifications, price schedule, diagrams/drawings together with the letter of intent / contract itself (Work Order / Purchase Order) and other documents and correspondence specifically indicated therein.
- ix. "Scope" means "Scope of product vendor, Implementation Partner & service provider as covered in Section II" of this document, which forms part of these documents
- x. "GCC" means General Conditions of Contract and "SCC" means Special Conditions of Contract which form part of these documents

- xi. "Tender Specification" shall mean the GCC, SCC, SCOPE as mentioned at Section 2, Instructions to Bidders read with notice to inviting tender and subsequent clarification if any furnished by the EMPLOYER for the purpose of submitting the offer by the Bidder.
- xii. "CC" means the Conditions of Contract.
- xiii. "SUPPLY, INSTALLATION& FMS ACTIVITY FOR PREPAID METER" covers the entire scope of this tender document.
- xiv. "Notice in Writing" or "Written Notice" as per clause 4.2 Notices.
- xv. "Schedule" or "Work Schedule" shall mean the accepted schedules between the Bidder and the EMPLOYER forming part of the contract.
- xvi. "Letter of Intent (LOI)/ Notice of award/ Letter of Award (LOA)" means intimation from the EMPLOYER by a letter / fax / email to the Bidder that his tender has been accepted in accordance with the provisions contained in that letter / fax / email.
- xvii. "Contract Price" means the sum indicated in the LOI subject to such additions thereto or deductions there from as may be made under the Provisions hereinafter contained
- xviii. "Date of award of contract" shall mean the date of issue of Letter of Intent or the date of issue of acceptance of tender or date of contract whichever is earlier.
- xix. "Approval of the EMPLOYER" shall mean the written approval by the EMPLOYER or his authorized representative of a document, a diagram / drawing or other particulars of matters in relation to the contract.
- xx. Words importing persons shall include firms, companies, corporations, associations or body of individuals whether incorporated or not. Words importing masculine gender or singular number shall also include the feminine gender and plural number and vice-versa where the contract so requires or permits.
- xxi. The contract and all correspondence between the EMPLOYER and the Bidder shall be in English language.
- xxii. "In charge" of Bidder is a person from the Implementation Partner/System Integrator appointed by Bidder. He will be deemed as authorized agent of the Bidder.
- xxiii. The headings to various clauses of this contract shall not be deemed to be part thereof or be taken into consideration in the interpretation or construction thereof of the contract.
- xxiv. "Technical Requirements" mean the requirements mentioned & referred in the Scope of Work given in Section II.

- xxv. "Implementation Schedule" means the Implementation Schedule documented in the Agreed and Finalized Project Plan.
- xxvi. "Bidding Documents" refers to the collection of documents issued by the MSEDCL to instruct and inform bidders of the processes for bidding, selection of the winning bid, and Contract formation, as well as the Contractual conditions governing the relationship between the MSEDCL and the Bidder .
- xxvii. Bidder's Representative" means any person nominated by the Bidder and named as such in the Contract Agreement and approved by the MSEDCL in the manner provided Tender (Bidder 's Representative) to perform the duties delegated by the Bidder .
- xxviii. "System" or "Subsystem" means any application component, developed application or module to meet the technical requirements that may be supplied, installed, tested, and commissioned individually before Commissioning of the entire SUPPLY, INSTALLATION& FMS ACTIVITY FOR PREPAID METER.
- xxix. "Services" means all technical, logistics, management, and any other Services to be provided by the Bidder under the Contract to supply/ develop, install, implement, customize, integrate, and make operational the proposed SUPPLY, INSTALLATION& FMS ACTIVITY FOR PREPAID METER. Such Services may include, but are not restricted to Installation, Commissioning, Go-Live, testing and Training.
- xxx. "The Project Plan" means the document to be developed by the Bidder and approved by MSEDCL based on the requirements of the Contract and the Development and Implementation Plan included in the bid. For the sake of clarity, "the Agreed and Finalized Project Plan" refers to the version of the Project Plan approved by the MSEDCL. The project plan may be changed/ modified during the course of the project. Should the Project Plan conflict with the Contract in any way, the relevant provisions of the Contract, including any amendments, shall prevail.
- xxxi. "Materials" means all the deliverables as per the agreement to be provided to MSEDCL under the Contract.
- xxxii. "Intellectual Property Rights" means any and all copyright, moral rights, trademark, patent, and other intellectual and proprietary rights, title and interests worldwide, whether vested, contingent or future including without limitation all economic rights and all exclusive rights to reproduce, fix, adapt, modify, translate, create derivative works from, extract or re-utilize data from, manufacture, introduce into circulation, publish, distribute, sell, license, sublicense, transfer, rent, lease, transmit or provide access electronically, broadcast, display, enter into computer memory, or otherwise use any portion or copy, in whole or in part, in any form, directly or indirectly, or to authorize or assign others to do so.
- xxxiii. "Offered Product for evaluation purposes" means the product offered by the vendor or its version predecessors.
- xxxiv. "Delivery" means delivery of different items at employer's site as per the scope given in Tender.

- xxxv. "Installation" means that the System or a Subsystem installed on the hardware and made available for Commissioning as provided in Tender.
- xxxvi. "Day" means calendar day of the Gregorian calendar.
- xxxvii. "Week" means seven (7) consecutive Days, beginning the day of the week as is customary in the India.
- xxxviii. "Month" means calendar month of the Gregorian calendar.
- xxxix. "Year" means a period of twelve (12) consecutive Months.
- xl. "Effective Date/ Kick-off Date" means the date of signing of the Contract Agreement, for the purpose of determining the Delivery, Installation, and Acceptance dates for the "SUPPLY, INSTALLATION& FMS ACTIVITY FOR THREE PHASE PREPAID METER".
- xli. "Contract Period" is the time period during which this Contract governs the relations and obligations of the MSEDCL and Bidder in relation to the SUPPLY, INSTALLATION& FMS ACTIVITY FOR THREE PHASE PREPAID METER

## **6.2 NOTICES**

Any notice, request or consent required or permission to be given or made pursuant to this contract shall be in writing. Any such notice, request or consent shall be deemed to this contract shall be in writing. Any such notice, request or consent shall be deemed to have been given or made when delivered in person addressed to an authorized representative of the party with whom the communication is, or were sent by registered mail, telex, telegram or facsimile to such Party at the address specified in the clause of submission of proposal.

## **6.3 INTERPRETATION**

- i. Language: All Contract Documents, all correspondence, and communications to be given shall be in English and the Contract shall be construed and interpreted in accordance with that language.
- ii. If any of the Contract Documents, correspondence, or communications are prepared in any language other than English, the translation of such documents, correspondence, or communications shall prevail in matters of interpretation. The originating party, with respect to such documents, correspondence, and communications, shall bear the costs and risks of such translation.
- iii. Headings: The headings and marginal notes in the CC are included for easy reference and shall neither constitute a part of the Contract nor affect its interpretation.
- iv. Persons: Words importing persons or parties shall include firms, corporations, and government entities.

- v. Entire Agreement: The Contract constitutes the entire agreement between the MSEDCL and Bidder with respect to the subject matter of Contract and supersedes all communications, negotiations, and agreements (whether written or oral) of parties with respect to the subject matter of the Contract made prior to the date of Contract.
- vi. Amendment: No amendment or other variation of the Contract shall be effective unless it is in writing, is dated, expressly refers to the Contract, and is signed by a duly authorized representative of each party to the Contract.
- vii. Severability: If any provision or condition of the Contract is prohibited or rendered invalid or unenforceable such prohibition, invalidity, or unenforceability shall not affect the validity or enforceability of any other provisions and conditions of the Contract.

## **6.4 RELATIONSHIP AND LIMITED AUTHORITY**

- i. The Bidder shall not have, nor shall he represent himself as having, any authority to commit the Board to any contract, agreement, or other legal commitments in the name of or binding on the Board or to pledge or extend credit in the name of the Board. The Bidder shall perform the scope and services hereunder as an independent Bidder and not as an employee, agent, partner or joint venture partner of the Board.

## **6.5 OBLIGATIONS OF THE SUPPLY, INSTALLATION & FMS ACTIVITY FOR THREE PHASE PREPAID METER**

### **i. GENERAL**

#### Standard of Performance

The bidder shall always act, in respect of any matter relating to this Contract or to the Services, as faithful advisor to the Owner.

### **ii. CONFIDENTIALITY**

The Bidder and their Personnel shall not, during the term and within two years after the expiration of this Contract, disclose any proprietary or confidential information relating to the Project, the services, this contract or the Owner's business or operations without the prior written consent of the Owner.

### **iii. DISCLOSURE**

The Bidder shall agree that the MSEDCL has the right to fully disclose this contract and the identity of the Bidder, if such disclosure is required by legal authority or necessary to satisfy lender(s) information requests in support of GoM approval process etc.

### **iv. INDEMNITY**

The Bidder assumes responsibility for and shall indemnify and save harmless the EMPLOYER, from all liability, claims, costs, expenses, taxes and assessments including penalties, punitive damages, attorney's fees and court cost which are, or may be required with respect to any breach of the Bidder's obligations under the Contract, or for which the Bidder has assumed responsibility under the Contract, including those imposed under any

contract, local or national and international law or laws, or in respect of all salaries, wages or other compensation of all persons employed by the Bidder in connection with performance of any work covered by the Contract. The Bidder shall execute and deliver such other further instruments to comply with all the requirements of such laws and regulations as may be necessary there under to confirm and effectuate the Contract and to protect the EMPLOYER.

The EMPLOYER shall not be in any way held responsible for any accident or damages incurred or claims arising there from during discharge of the obligations by Bidder under this contract.

**v. Liability of the Bidder**

Subject to additional provision, if any, the Bidder's liability under this contract shall be as provided by the Applicable Law

**vi. Bidder's actions requiring owner's prior approval**

The Bidder shall obtain the Owner's prior approval in writing before taking any of the following actions:

- i) Appointing or removing any member of the Personnel as are listed in their bid ("Bidder's Key Personnel")
- ii) Taking up a similar kind of project elsewhere during discharge of duties /obligations under this contract.

**vii. Assignment And Subletting**

The Bidder shall not transfer or sublet or assign the contract or any part thereof or any benefit or interest therein or there under. In the event of the Bidder contravening this condition, the EMPLOYER shall be entitled to place the contract elsewhere on the Bidder's account and at his risk and then the Bidder shall be liable for any loss or damage which the EMPLOYER may sustain in consequence or arising out of such replacing of contract.

**viii. Patent Infringement**

The Bidder shall protect, indemnify and save harmless the EMPLOYER, his customers and users of his products, against all liability, including cost, expenses, claims, suits or proceedings at law in equity or otherwise, growing out of or in connection with any actual or alleged patent infringement (including process patents, if any) or violation of any license and will defend or settle at the Bidder's own expense any such claims, suits or proceedings.

The EMPLOYER will notify the Bidder in writing of any such claim, suit, action or proceeding coming to his attention, giving authority and all available information and assistance for the Bidder's defense of the same. The Bidder shall appoint a counsel at his own expenses in consultation with the EMPLOYER to collaborate in the defense of any such claim, suit, action or proceeding.

**ix. Reporting Obligations**

The Bidder shall submit, to the Owner, the final project report along with the documents in the format as needed by the owner.

## 6.6 TERMINATION OF THE CONTRACT

Termination for Purchaser's Convenience: The Purchaser may at any time terminate the Contract for any reason by giving the Bidder a ninety days (90) notice of termination that refers to this Clause.

- i. Upon receipt of the notice of termination under above Clause, the Bidder shall either as soon as reasonably practical or upon the date specified in the notice of termination cease all further work, except for such work as the Purchaser may specify in the notice of termination for the sole purpose of protecting that part of the "SUPPLY, INSTALLATION OF THREE PHASE PREPAID METER AND IMPLEMENTATION OF FMS" already executed, or any work required to leave the site in a clean and safe condition. In addition, the Bidder, subject to the payment specified in below Clause, shall deliver to
  - A. The Purchaser the parts of the "SUPPLY, INSTALLATION OF THREE PHASE PREPAID METER AND IMPLEMENTATION OF FMS" executed by the Bidder upto the date of termination;
  - B. The extent legally possible, assign to the Purchaser all right, title, and benefit of the Bidder to the "SUPPLY, INSTALLATION OF THREE PHASE PREPAID METER AND IMPLEMENTATION OF FMS" , or Subsystem, as at the date of termination, and, as may be required by the Purchaser;
  - C. The Purchaser all non-proprietary drawings, specifications, and other documents prepared by the Bidder as of the date of termination in connection with the "SUPPLY, INSTALLATION OF THREE PHASE PREPAID METER AND IMPLEMENTATION OF FMS".
- ii. In the event of termination of the Contract under above Clause, the Purchaser shall pay to the Bidder the payment for invoices submitted prior to the effective date of termination.

### iii. Termination for Bidder's Default

- A. The Purchaser, without prejudice to any other rights or remedies it may possess, may terminate the Contract forthwith in the following circumstances by giving a notice of termination and its reasons therefore to the Bidder, referring to this Clause.
  - a. If the Bidder becomes bankrupt or insolvent, has a receiving order issued against it, compounds with its creditors, or, if the Bidder members are corporation, a resolution is passed or order is made for its winding up (other than a voluntary liquidation for the purposes of amalgamation), a receiver is appointed over any part of its undertaking or assets, or if the Bidder takes or suffers any other analogous action in consequence of debt;
  - b. If the Bidder assigns or transfers the Contract or any right or interest therein in violation of the provision of Tender Clause (Assignment and subletting);
  - c. If the Bidder, in the judgment of the Purchaser, has engaged in corrupt or fraudulent practices in competing for or in executing the Contract, including but not limited to willful misrepresentation of facts concerning ownership of Intellectual Property Rights in, or proper authorization and/or licenses from the owner to offer, the hardware, software, or materials provided under this Contract;
  - d. If the Tenderer, before contract award, has committed a transgression through a violation of any of the terms under contract agreement or in any other form such as to put his reliability or credibility as Tenderer in to question, the Principal is entitled to disqualify the tenderer from the tender process or to terminate the contract, if already signed for such reason;
  - e. If the tenderer, after the Contract award has committed a transgression through a violation of any of the tender terms or in any other form such as to put his reliability or credibility as Tenderer in to question, the Principal is entitled also to exclude the Tenderer / Contractor

from future contract process. The imposition and duration of the exclusion will be determined by the severity of the transgression. The severity will be determined by the circumstances of the case, in particular the number of transgressions, the position of the transgressors within the company hierarchy of the Tenderer / Contractor and the amount of damage. The exclusion will be imposed for a minimum of 6 months and a maximum of 3 years.

- B.** If the Bidder:
- a. Has abandoned or repudiated the Contract;
  - b. Has without valid reason failed to supply & installation and implementation of meter reading through DCU in project area as per Milestone (Annexure – XI) submitted by the bidder.
  - c. Has failed to submit minimum 75 % meter data/readings through DCU for consecutive three months period in the awarded project area.
  - d. Persistently fails to execute the Contract in accordance with the contract or persistently neglects to carry out its obligations under the Contract without just cause;
  - e. Refuses or is unable to provide sufficient Materials, Services, or labour to execute and complete the SUPPLY, INSTALLATION OF THREE PHASE PREPAID METER AND FMS in the manner specified in the Agreed and Finalized Project Plan furnished at rates of progress that give reasonable assurance to the Purchaser that the Bidder will implement as above solution in given area, then, the Purchaser may, without prejudice to any other rights it may possess under the Contract, give a notice to the Bidder stating the nature of the default and requiring the Bidder to remedy the same. If the Bidder fails to remedy or to take steps to remedy the same within fourteen (14) days of its receipt of such notice, then the Purchaser may terminate the Contract forthwith by giving a notice of termination to the Bidder that refers to this Clause.
  - f. Upon receipt of the notice of termination, the Bidder shall, either immediately or upon such date as is specified in the notice of termination:
    - a. Cease all further work, except for such work as the Purchaser may specify in the notice of termination for the sole purpose of protecting that part of the “SUPPLY, INSTALLATION OF THREE PHASE PREPAID METER AND IMPLEMENTATION OF FMS” already executed or any work required to leave the site in a clean and safe condition;
    - b. Deliver to the Purchaser the parts of the “SUPPLY, INSTALLATION OF THREE PHASE PREPAID METER AND FMS by the Bidder up to the date of termination, subject to the receipt of payment stated in clause.
    - c. To the extent legally possible, assign to the Purchaser all right, title and benefit of the Bidder to the “SUPPLY, INSTALLATION OF THREE PHASE PREPAID METER AND FMS IMPLEMENTATION” or subsystems as at the date of termination, Contract.
    - d. Deliver to the Purchaser all drawings, specifications, and other documents prepared by the Bidder as at the date of termination in connection with the “SUPPLY, INSTALLATION OF THREE PHASE PREPAID METER AND FMSIMPLEMENTATION”.
    - e. After termination of contract, infrastructure installed by the agency such as DCU, Gateways, data collection software etc. shall be handed over to MSEDCL. All hardware and software installed during the contract period will be treated as MSEDCL property.
- iv.** The Purchaser may enter upon the site, expel the Bidder, and complete the “SUPPLY, INSTALLATION OF THREE PHASE PREPAID METER AND IMPLEMENTATION OF FMS itself or by employing any third party. Upon completion of the “SUPPLY, INSTALLATION OF THREE PHASE PREPAID METER AND IMPLEMENTATION OF FMS” or at such earlier date as the Purchaser thinks appropriate, the Purchaser shall give notice to the Bidder that such Bidder’s Equipment will be returned to the Bidder at or near the site and shall return such Bidder’s Equipment to the Bidder in accordance with such notice. The Bidder shall thereafter without delay and at its cost remove or arrange removal of the Bidder’s Equipment from the site.



## 6.7 FORCE MAJEURE

- i. If at any time during the continuance of the Contract, the performance in whole or in part by either party or any obligations under the Contract shall be prevented or delayed by reason of any war, hostilities, act of public enemy, civil commotion, sabotage, fire, floods, explosions, epidemics, quarantine restrictions and Acts of God (hereinafter referred to as 'Events') and provided notice of the happening of any of the above mentioned Event duly certified by Indian Chamber of Commerce in case of Indian Parties or International Chamber of Commerce, Paris, France in case of foreign parties) is given by either party to the other within fifteen(15) days from the date of occurrence thereof, the EMPLOYER shall have the right by reason of such Event to terminate the Contract without however affecting the right to any claim for damages on the Bidder in respect of such non-performance or delay in performance. However, in the event of the EMPLOYER having agreed, the services under the Contract shall be resumed after such Event has come to end/ceases to exist. Should one or both the parties be prevented from fulfilling their contractual obligations by a state of force majeure lasting continuously for a period of at least 6 months and the EMPLOYER not having terminated the Contract by that time, the two parties shall consult each other regarding the further implementation of the Contract with the provision that if no mutually satisfactory arrangement is arrived at within a period of 3 months from the expiry of 6 months referred to above, the Contract shall be deemed to have expired at the end of the 3 months referred to above. The above mentioned expiry of the Contract will imply that both the parties have obligations to reach an agreement regarding the winding up and financial settlement of the Contract.
- ii. In addition to above, the situation arising because of theft of meters, meter burnt and damage at any time during the continuance of the Contract will be covered under force majeure clause subject to due verification by MSEDCL.

## 6.8 FAIRNESS AND GOOD FAITH

### i. Good Faith

The parties undertake to act in good faith with respect to each other's rights under this contract and to adopt all reasonable measures to ensure the realization of the objectives of this contract.

### ii. Operation of Contract

The parties recognize that it is impractical in this contract to provide for every contingency, which may arise during the life of this contract, and the parties hereby agree that it is their intention that this contract shall operate fairly as between them and without detriment to the interest of either of them.

## 6.9 SETTLEMENT OF DISPUTES

- i. The decisions, opinions, directions, certificates of valuation of the MSEDCL with respect to all or any of the matters under Tender clauses and special conditions of contract for the decision of which specific provisions have been made here of, which matters here in referred to as "excepted matters" shall be final and conclusive and binding on the parties hereto shall be without appeal.
- ii. Any notice to be given to the Bidder under the terms of these conditions shall be considered as duly served if the same shall have been delivered to, left for, or posted by registered post to

the address of the Bidder at their registered office or address given in the tender. Similarly, any notice to be given to the EMPLOYER shall be considered as duly served, if the same shall have been delivered to, left for, or posted by registered post to the EMPLOYER'S office at Mumbai

- iii. The Agreement shall in all respects be construed and carried into effect and rights and liabilities of the parties hereto shall be regulated according to the laws of India.
- iv. Mutual Settlement of Disputes : Except where otherwise provided for in the contract, all questions and dispute relating to any matter directly or indirectly connected with this agreement shall in the first place be resolved through mutual discussions, negotiations, deliberation and consultations between both the parties.
- v. Conciliation: If the effort to resolve all or any of the disputes through mutual settlement fails, such disputes shall be referred to the conciliator to be appointed by the mutual agreement of both the MSEDCL and the Bidder. The conciliator shall make the settlement agreement after the parties reach agreement and shall give an authenticated copy thereof to each of the parties. The settlement agreement shall be final and binding on the parties. The settlement agreement shall have the same status and effect of an arbitration award. The venue of Conciliation shall be Mumbai, Maharashtra, India.
- vi. Arbitration: Any disputes, differences, whatsoever, arising between the parties out of or relating to the construction, meaning, scope, operation or effect of this Contract shall be settled between the MSEDCL and the Bidder amicably as mentioned in Tender. If however, MSEDCL and the Bidder are not able to resolve their disputes / differences amicably as aforesaid the said disputes / differences shall be settled by Arbitration. The Arbitration proceedings, in case of foreign Contractor shall be regulated and governed by the rules of Arbitration and Conciliation of International Chamber of Commerce, Paris. The venue shall be Mumbai, Maharashtra, India.
- vii. The arbitration proceedings in case of Indian Contractor shall be regulated and governed by Arbitration and Conciliation Act, 1996 and the statutory modification thereof to the said act if any. Each party shall appoint its arbitrator; the two arbitrators so appointed shall appoint a third arbitrator who shall be the presiding arbitrator. The Arbitral Tribunal shall give a reasoned award. The award made in pursuance thereof shall be binding on the parties. The arbitration shall be governed and regulated in all respect according to Laws of India. The venue shall be Mumbai, Maharashtra, India.
- viii. The further progress of any work under the contract shall unless otherwise directed by the EMPLOYER continue during the arbitration proceedings and no payment due or payable by the EMPLOYER shall be withheld on account of such proceedings. It shall not be open to arbitrator(s) to consider and decide whether or not such work shall continue during the arbitration proceedings.
- ix. The courts at Mumbai, Maharashtra, India shall alone have jurisdiction and the applicable laws shall be the Laws of India.

## 6.10 Policy & Procedure for Debarring of Agency from Business Dealings with MSEDCL

(...In addition to Tender and other conditions and relevant Law)

### 1. Scope:

- 1.1 MSEDCL reserves its right to debar any Agency from any business dealings with it, if such Agency is found to have committed deception, fraud or misconduct or any other act which is not in the interest of MSEDCL in the execution of contracts awarded or any of its action(s) fall into any such categories as laid down in this policy.
- 1.2 The provisions of this policy will be effective on investigations conducted or misconduct/irregularities noticed on the part of any Agency in all contracts awarded on or after the date of implementation of this policy.

### 2. Definitions:

In this policy, unless the context otherwise requires:

- 2.1 **Agency** shall mean Contractor / Supplier / Purchaser / Bidder/ Vendor/ MSEDCL approved sub-contractor of a Contractor to whom work has been awarded. It shall include, but not limited to, a public limited company or a private limited company, a firm whether registered or not, a proprietorship, any individual, a cooperative society or an association or a group of persons engaged in any commerce, trade, industry, or constituents of an unincorporated Joint Venture Company, etc.
- 2.2 **Bid/ Tender** shall mean an offer, proposal or quote for goods, services or works in response to solicitation issued for such goods, services or work by MSEDCL.
- 2.3 **'Competent Authority' and 'Appellate Authority'** shall mean the following :-  
 For Purchase Order (LOA) value up to & below 10 Cr., the Director Project / Director Operation shall be the 'Competent Authority'. The Chairman & Managing Director (CMD) shall be 'Appellate Authority' in respect of such cases.  
 For Purchase Order (LOA) value above 10 Cr., the Chairman & Managing Director (CMD) shall be the 'Competent Authority'. The Board of Directors shall be the 'Appellate Authority' in respect of such cases.
- 2.4 **'Enquiring Committee'** (EC) shall mean the following:-  
 The Committee comprising Chief Engineer (MM Dept), Chief General Manager (I/A) and Chief Legal Advisor shall be the Enquiring Committee
- 2.5 **Debarring;** - Business dealings with an agency may be debarred if it is considered not desirable to continue the business with the agency. It means action taken by the Competent Authority / Appellate Authority pursuant to this policy prohibiting agency from directly or indirectly performing any work for or otherwise participating in MSEDCL bid / tender including to prohibit agency from submitting a bid, having a bid considered, or entering into any work / contract during a specified period of time as set forth in debarment order.
- 2.6 **'Purchase Order Issuing Authority (LOA)' & 'Vender Approving Authority(VA)'**: Shall mean the person(s) designated to act for and on behalf of MSEDCL for the discharge of his duties in execution of the Work / Project / Job / Role, and shall include but not limited to the Regional Director(s), Executive Director(s), Chief Engineer(s), Superintending Engineer(s), Executive Engineer(s), etc.

### 3. **Grounds for Debarring:**

3.1 Debarring from business dealings can be initiated against the Agency if involved or committed any of the following misconduct / irregularities:

- a) The Directors, Proprietors, Partners, Employee(s) or owner of the agency have been either jointly or severally guilty of malpractices such as fraud including but not limited to submission of fake or forged documents / certificates / guarantees, substitution of tenders, etc. in relation to its business dealings with the Government or MSEDCL, during the last five years.
- b) The business dealings with the agency have been debarred by any Ministry of GoI / GoM / state owned electricity distribution utility and still in force.
- c) The agency is found to have been in default in paying any dues resulting in incurring financial loss to the MSEDCL by virtue of an order and/or direction of any Statutory Authority or Court or Arbitration, etc. for making such payment in respect of the agency concerned.
- d) The agency is repeatedly found to be non performing in execution of 3 (three) or more contracts and / or in rectification of critical / major defects pointed out by MSEDCL or any person authorized by MSEDCL, in last 5 (five) years.

The grounds given above are only illustrative and not exhaustive. The Competent Authority may decide to debar an Agency according to the seriousness of the ground.

3.2 a) The Competent Authority shall decide depending upon the level of severity in defaults from the agency, the period of debarring. In case of major lapses and a criminal or fraudulent type of issues involved therein, the First Information Report (FIR) to Police Department shall be lodged.

b) If any one or more Partner / Directors of any debarred Agency firm promotes or forms a new contracting firm or a sister-concern firm of the said debarred Agency, then it shall also be considered as a debarred firm.

### 4. **Competent Authority (CA) and Appellate Authority (AA) for Debarment:**

Considering the above mentioned grounds for Debarring from business dealings can be initiated against the Agency, after due scrutiny by the Purchase Order issuing authority (LOA) or Vender Approving Authority (VA) and shall serve upon the 'Show Cause Notice' for Debarring of the Agency after termination of contract is affected. For the purpose of debarment, the powers delegated to the following designated officers of MSEDCL as Competent Authority (CA) and as Appellate Authority (AA) for debarring of business dealings with the accused Agency.

Sr. No.	Purchase Order Issuing Authority (LOA) & Vender Approving Authority (VA)	Enquiring Committee (EC)	Competent Authority for Debarring (CA)	Appellate Authority for Debarring (AA)
1	Orders from Corporate Office	For orders below Rs. 10 Cr.	Director(Project) / Director (Operation)	Chairman & Managing Director (CMD)
		For orders above 10 Cr.	Chairman & Managing Director (CMD)	BOARD OF DIRECTORS

### 5. **Powers of Competent Authority and Appellate Authority:-**

- a) To investigate the matter in connection with the allegation of corrupt, fraudulent, coercive or collusive practices or illegal practice of agencies;
- b) To ensure timely and expeditious disposal of proceedings of debarment;

- c) Seek advice or opinion on specific issues.

## **6. Procedure:**

The Purchase Order Issuing Authority (LOA) or Vendor Approving Authority (VA) of the concerned department on noticing any misconduct and / or irregularities as mentioned in clause 3.1 above, shall serve upon the 'Show Cause Notice for Debarring' after termination or closing of contract(s) stating therein the facts / reasons containing the allegation of misconduct or irregularities and the period of 14 days will be afforded to the agency to present their statement / submission in the form of reply in response to Show Cause Notice. In the event, non receipt of reply from the agency within the stipulated period, action as proposed will be proceeded with and no representation / submissions thereafter will be accepted. The copy of service return of notice will be kept and a confirmatory document through electronic mode is sine qua non.

- a. The Purchase Order Issuing Authority (LOA) or Vendor Approving Authority (VA) shall submit the duly recommended detailed proposal of debarring of Agency to the Competent Authority (CA) along with Show cause notice and reply, if any and para-wise justification to the reply to the Show Cause Notice submitted by the Agency, if any for consideration and order.
- b. The Competent Authority (CA) shall scrutinize the proposal and depending on merit of the case and after examining the material on record shall decide to proceed for enquiry or to close the case. In the event of exoneration of the Agency from debarring, the decision shall be conveyed to LOA or VA issuing authority and subsequently it shall be informed to Agency.
- c. If the Competent Authority (CA) arrives at the decision to proceed in the matter, then the complete case shall be handed over to the Enquiring Committee (EC). The Enquiring Committee shall in detail examine the materials on record, conduct the hearing and decide the case as per the principle of natural justice.

During the process of hearing, only the authorized representative of Agency will be permitted to represent the Agency and no Legal practitioner / Advocate shall be allowed to plead the case on its behalf.

- d. The Enquiring Committee shall submit its Report along with detailed findings within 30 days to the Competent Authority (CA).

The Competent Authority (CA) shall pass an appropriate order after examining the material on record.

- e. The decision of the Competent Authority (CA) shall be in the form of Reasoned Order, the period for which the debar would be operative shall be mentioned in the order and the same shall be communicated to the LOA or VA issuing authority.
- f. The Purchase Order Issuing Authority (LOA) or Vendor Approving Authority (VA) shall then communicate the decision of debarring of business dealings along with the order of Competent Authority (CA) to the Agency.
- g. The procedure for debarring shall be completed within a period of three months from initiation of case by concerned authority.

The Reasoned Order will be communicated to the agency at its recorded address available with MSEDCL within 15 days of order issued by Registered post. In addition to it, the copy shall preferably be sent on the registered Email address of the Agency.

## **7. Period of Debarment:**

The period for which an agency is debarred shall be clearly mentioned in the order. Period of debarment of business dealings shall be decided by the Competent Authority in exercise of its power delegated and would depend upon the seriousness of the cause. Debarment shall be up to the maximum period of five (5) years.

Provided further that in case the information / documents submitted by the agency is found to be false / forged at any point of time, MSEDCL shall have a right to recover from the agency the cost incurred in carrying out physical assessment for establishing veracity of such information / document including a penalty decided by the Enquiring Committee. If the agency fails to reimburse such cost and penalty to

MSEDCL, the debarment period of the agency may be extended by the Enquiring Committee which shall not in any case exceed more than two (2) years but in any cumulative period for debarring the Agency shall not exceed five (5) years, in exceptional cases such period shall be up to five (5) years and the cumulative period for debarring of agency in such cases shall not exceed ten (10) years.

## **8. Consequences of Debarment:**

Upon issuance of the order of debarment of an agency from future business dealings with MSEDCL, the debarred agency along with its Joint Venture Partner Firm shall not be allowed to participate in any future tender/s, during the debarred period. Further, in case the agency has already participated in the tender process and the price bid is not opened prior to issuance of the order of debarment of business dealings, its Techno Commercial Bid shall be rejected and Price Bid shall not be opened.

In the event the Price Bid of the participating agencies has been opened and the agency against whom the order of debarment of business dealings has been issued, the bid of the debarred agency shall be rejected even if he is found to be successful bidder, considering the agency as disqualified.

Provided the order of debarment of business dealings issued against any agency shall not override the rights of the debarred agency already engaged in executing any other contract(s) till its completion.

## **9. Withholding:**

The Competent Authority (CA) may, depending on the severity of the case, withhold the business dealing with the agency till the report given by the Enquiring Committee from the date of initiation of proposal of debarring.

## **10. Appeal against the Debarment Order:**

- a. The Agency, aggrieved by the order of debarment, may prefer an appeal before the Appellate Authority (AA), against the order of the Competent Authority (CA) specifying the grounds of appeal along with necessary documents.
- b. Such appeal shall be filed within one month from the date of receipt of the order of debarment of business dealing. The agency shall represent their case through authorized representative of its agency, and no service of legal practitioner shall be adopted.
- c. Purchase Order Issuing Authority (LOA) or Vendor Approving Authority (VA) shall submit all the original papers of the debar case to Appellate Authority (AA), along with the justification on points raised in appeal by debarred Agency.
- d. Appellate Authority shall admit the appeal and decide the appeal within 45 days from the filing of appeal. The agency may file any additional document/evidence before the Appellate Authority, if Appellate Authority permits.
- e. Appellate Authority shall pass appropriate Reasoned Order on appeal and communicate decision to the Purchase Order Issuing Authority (LOA) or Vendor Approving Authority (VA) through the Competent Authority (CA). LOA or VA Issuing Authority will then communicate appeal order to the Debarred Agency.

No appeal will lie to the Appellate Authority against the final order of the competent authority pursuant to the written consent of the agency.

Awaiting the decision of the competent authority, the debarring order passed by the competent authority shall remain effective till Appellate Authority takes a final decision in the matter.

The order of the Appellate Authority is final and binding.

## **11. Revocation of Debarment Order :**

The order for debarment passed for certain specified period shall be deemed to have been automatically revoked on expiry of the specified period and it will not be necessary to issue a specific formal order of revocation.

An order of debarment for the reasons mentioned above may be revoked if accused has been wholly exonerated by Court of Law.

**12. Interpretation :**

The competent authority shall be responsible for the administration, interpretation, application and revision of this policy. The policy will be reviewed as and when needed.

**13. Post Debarment Action:**

The Competent Authority (CA) will ensure the following;

- a) Hosting at MSEDCL Website: The name of the Agencies with whom Business Dealings have been debarred shall be hosted at MSEDCL website by HO-IT Department, after confirmation of Debarment of the Agency.
- b) The Competent Authority shall ensure that the names of the debarred agency along with the names of Director, JV Partner, Owner of the debarred Agency is displayed on the MSEDCL website.
- c) The cancellation is activated for Online Login for e-Tendering website of MSEDCL for the debarred Agency Firm during the period of debarment.
- d) Copy of the order of debarring of the Agency shall be conveyed to all Utilities in India and Financial Institutions viz. REC, PFC, etc. and Ministry of Power of both GOM and GOI.

**14. AMENDMENTS :**

MSEDCL may introduce modification thereto through the amendment of its specific provision as the need arises and the amendment to this policy shall be applicable to the ongoing contract as well future contract.

## **SPECIAL CONDITIONS OF CONTRACT**

Special Conditions of Contract (SCC) shall be read in conjunction with all the conditions specified in the General Conditions of Contract, scope for "SUPPLY, INSTALLATION OF THREE PHASE PREPAID METER AND IMPLEMENTATION OF FMS", Instructions to tender read with notice inviting tender and any of their documents forming part of this tender where ever context so requires.

### **1 : TENDER SAMPLE**

For testing of tender sample meters at any one NABL Lab. And IT Section of MSEDCL tenderer are required to submit 10 (Ten) nos. of sample meters out of which one is without ultrasonic welding as per technical specifications along with the connecting telephonic cable with connectors fixed to cable, API / Exe file with documentation and web based prepaid application prepaid engine, documentation, Exe / API for validating downloaded meter data, etc. of offered type / item in the office of the Chief Engineer, MSEDCL, Material Management Dept., 1st Floor, Prakashgad, Bandra (E), Mumbai – 400 051 on or before the time & date stipulated for submission of offer

The Cl. No.23 of technical specification stands modified to this extent and other stipulations of Cl. No.23 of technical specification will remain unchanged.

#### **Packing of tender samples:**

"Sample meters shall be suitably packed in order to avoid damage during transit or handling. In case, the sample meters found damaged, it shall be the bidder's sole responsibility. Therefore, bidders should ensure that the meters packed are intact."

### **2 : ORDER QUANTITY, DELIVERY SCHEDULE AND QUALITY TESTING**

- a] The L.O.A. will be issued for entire ordered quantity and same shall be considered as release order for entire quantity.
- b] The sample meters drawn from first lot and subsequent lot shall be sent for type test to NABL lab for Quality Testing.
- c] In case of failure of the sample meters in type tests (Quality Testing), then the balance ordered quantity shall stand cancelled & for the quantity already accepted against the order and used, deduction in price of 10% of the value of material supplied plus applicable taxes, if any shall be made

### **3 : GUARANTEE**

For Meter:

"The meter shall be guaranteed for the period of five years from the date of commissioning or five and half years from the date of dispatch whichever is earlier".

### **4 : CONTRACT PERFORMANCE DEPOSIT**

The contract performance deposit shall be an amount equal to 5% of the contract value in the form of unconditional & irrevocable BG and to be submitted after the first consignment is effected and when the payment thereof becomes due to the contractor.



## Other Particulars

### A. ROLE OF BIDDER

1. The Bidder has the overall responsibility as per the Scope mentioned at Clause -2 of this document.
2. The Bidder shall be responsible for timely provision of all resources, information, and decision making under its control that are necessary to reach a mutually agreed and Finalized Project Plan as per delivery schedule of scope of work. Failure to provide such resources, information, and decision-making may constitute grounds for termination.
3. The Bidder shall acquire in its name all permits, approvals, and/or licenses from all local, state, or national government authorities or public service undertakings that are necessary for the performance of the Contract.
4. For any of the communication solution proposed by the bidder, selection of service provider will be responsibility of the bidder. MSEDCL will provide to the bidder the required SIM cards, under NBSP contract with service provider such as Airtel, Vodafone, Idea and Tata.
5. The Bidder shall comply with all laws in force in India. The laws will include all national, provincial, municipal, or other laws that affect the performance of the Contract and are binding upon the bidder. The Bidder shall indemnify and hold harmless the MSEDCL from and against any and all liabilities, damages, claims, fines, penalties, and expenses of whatever nature arising or resulting from the violation of such laws by the Bidder or its personnel, but without prejudice to Tender Conditions. The Bidder shall not indemnify the MSEDCL to the extent that such liability, damage, claims; fines, penalties, and expenses were caused or contributed to by a fault of the MSEDCL.
6. The Bidder shall provide the key personnel namely the Project Leader, Module Leaders, Quality Assurance personnel any Specialist/Analysts required as appropriate, need to have sufficient experience as per Tender Conditions in terms of relevance and number of years required to implement the "SUPPLY, INSTALLATION OF THREE PHASE PREPAID METER AND IMPLEMENTATION OF FMS". Should the profile of any personnel be not acceptable to the MSEDCL will require the Bidder to suitably replace such personnel. They are to be assigned to the project on full time basis.
7. If for any reason beyond the control of the Bidder, there arises a need to replace any personnel, the Bidder shall provide a replacement person of equivalent or better qualification and experience, subject to the written approval of the MSEDCL.
8. Neither the Bidder nor its Personnel shall during the term of this Contract, engage in any business or professional activities in India/ Abroad which would conflict with the activities assigned to them under this Contract.
9. The Bidder is responsible for performing and safely storing, timely and regular backups of its data and Software in accordance with accepted data management principles, except where such responsibility is clearly assigned to the MSEDCL elsewhere in the Contract.
10. The Bidder will have primary responsibility for the successful running and stabilization in accordance with Tender Conditions.
11. In case project gets delayed due to any reason attributed to Bidder, no additional payment shall be done.

### B. ROLE OF MSEDCL

1. The MSEDCL shall ensure the availability of all information and/or data to be supplied by the MSEDCL to the Bidder.

2. The MSEDCL will provide the monthly reading program to the implementing agency at the beginning of each month. Also MSEDCL will issue identity cards to staff of the bidder.
3. The MSEDCL will designate appropriate staff or the training courses to be given by the Bidder and shall endeavor to make all appropriate logistical arrangements for such training as specified in the tender, the Agreed and Finalized Project Plan, or other parts of the Contract.

### **C. PROJECT PLAN**

1. In close cooperation with the MSEDCL and based on the Preliminary Project Plan included in the Bidder's bid, the Bidder shall develop a Project Plan encompassing the activities specified in the Contract.
2. The Bidder shall formally present to the MSEDCL the Project Plan in accordance with the Technical Requirements. The bidder has to specify the strategy and methodology with time frame and the synchronization of various phases of Project to ensure completion of Project in time. The Project plan shall also include a PERT chart describing the activities, resources required on the time for completion. The plan shall also bring out the critical areas needing continuous attention of the MSEDCL.
3. If required, the impact on the Implementation Schedule of modifications agreed during finalization of the Agreed and Finalized Project Plan shall be incorporated in the Contract by amendment, in accordance with Tender Conditions.
4. The Bidder shall undertake to supply, install energy meters and implement, integrate, commission AMR solution in accordance with the Agreed and Finalized Project Plan and the Contract.
5. The Progress and other reports specified shall be prepared by the Bidder and submitted to the MSEDCL in the format and frequency specified in the Agreed and Finalized Project Plan.

Changes to the Project Plan, if required, shall be made with the mutual consent of the MSEDCL and the Bidder.

### **D. PRODUCT UPGRADES**

1. At any point during performance of the Contract, shall technological advances be introduced by the Bidder for Subsystems originally offered by the Bidder in its bid and still to be delivered, the Bidder shall be obligated to offer to the MSEDCL the latest versions of the available Subsystem having equal or better performance or functionality at the same or lesser unit prices, pursuant to Tender Conditions.
2. During performance of the Contract, the Bidder shall offer to the MSEDCL all new versions, releases, and updates as well as related documentation and technical support services, within twenty eight (28) days of their availability from the Bidder to other clients of the Bidder in the MSEDCL's Country, and no later than twelve (12) months after they are released in the country of origin. In no case will the prices for this Software exceed those quoted by the Bidder in the Price Schedule form in its bid.
3. During the contract period the MSEDCL may require the Bidder to provide at no additional cost to the MSEDCL all new versions, releases within twenty eight (28) days of their availability from the Bidder to other clients of the Bidder in the MSEDCL's country, and no later than twelve (12) months after they are released in the country of origin of the Software.
4. The MSEDCL may at its discretion introduce all new versions, releases or updates of the Software provided that the new version, release, or update does not adversely affect the operation or

performance. In cases where the new version, release, or update adversely affects the System operation or performance, or requires extensive reworking, the Bidder shall continue to support and maintain the version or release previously in operation for as long as necessary to allow introduction of the new version, release, or update. In no case shall the Bidder stop supporting or maintaining the version or release of the Software in operation, during the contract period. The MSEDCL shall use all reasonable endeavors to implement any new version, release, or update.

1. No unauthorized code: The Bidder shall not end any software that the MSEDCL is not licensed to use, unless the product is activated by a required license key. The Bidder shall also certify that all their products and updates as supplied to the MSEDCL shall be free from viruses, worms, Trojans, spy-ware etc.

#### **E. GOVERNANCE LAW**

1. This contract, its meaning and interpretation, and the relation between the Parties shall be governed by the Applicable Law. The laws applicable to this contract shall be the laws in force in India. The courts of Mumbai, India shall have exclusive jurisdiction in all matters arising under and on account of this contract.

#### **F. GENERAL**

1. There shall be no suspension of work on account of arbitration provided that the obligations of the MSEDCL and bidder shall not be altered by reasons of arbitration being conducted during the progress of Works. Neither party shall be entitled to suspend the work to which the dispute relates on account of arbitration.
2. The cost of arbitration shall be borne by the Implementation partner. The cost shall inter-alia include the fees of the arbitration(s) as per the rates fixed by the arbitrator from time to time.
3. The parties agree to comply with the awards resulting from arbitration and waive their rights to any form of appeal insofar as such waiver can validly be made.

#### **G. INSURANCE**

The insurance as per GoM guidelines and safety of all men and material of the Bidder at the MSEDCL's site shall be the responsibility of the Bidder. The Bidder, at his cost shall arrange, secure and maintain insurance as may be necessary and for all such amounts to protect his interests and the interests of the Owner against all risks.

#### **H. BID SECURITY**

The bid security of the successful bidder will be returned when the bidder has signed the Contract Agreement and furnished the required performance guarantee. The bid security of the unsuccessful bidders will be returned as promptly as possible, afterward and signing of the Contract Agreement or expiration of the period of bid validity, whichever is earlier.

#### **I. PERFORMANCE GUARANTEE/SECURITY DEPOSIT**

Within 14 (fourteen) days of receipt of the Letter of Award from the Employer, the successful bidder shall furnish to the Employer a Performance Bank Guarantee Bond for proper performance of the Contract as well as satisfactory performance of operational support, Product & Implementation to an amount not less than Five Percent (5%) of the Contract Price in

accordance with the Conditions of Contract. The form of performance guarantee is provided in Annexure – IV (B) of the bidding documents may be used or some other form acceptable to the Employer. The performance guarantee shall be denominated solely in Indian Rupees, and shall be in the form of an unconditional and irrevocable Bank Guarantee issued by a Nationalized or Scheduled Bank. The bank guarantee shall, if invoked, be encashable when presented in the branch office of such Bank located in Mumbai, Maharashtra.

1. Failure of the successful bidder to comply with the requirements Tender Conditions shall constitute sufficient grounds for the annulment of the award and forfeiture of the bid security.
2. The Performance Bank Guarantee shall be returned to the bidder after successful completion of the entire work to the fullest satisfaction of the Employer at the end of the contract period that is after the defect liability period.
3. The successful bidder is required to fulfill requirement of Product & Implementation as per criteria defined in this document, for a period of five years from the date of start of project.
4. If required the amount and validity of additional Bank Guarantee/s in case of any changes necessitated to be submitted by the successful bidder shall be calculated by the Employer on the basis of details to be provided by the successful bidder. The successful bidder has to submit the fresh performance guarantee two months prior to completion of work. In case the contractor fails to submit the information and fresh Performance Guarantee, the retention amount available with the Employer will be withheld & it will be released only after submission of the required Performance Guarantee, by the successful bidder.
5. If Bidder or their employees damage, break, deface the property belonging to the EMPLOYER or others during the execution of the contract, the same shall be made good by the Bidder at his own expense and in default thereof; the MSEDCL may cause the same to be made good by other agencies and recover expenses from the Bidder for which the certificate of the MSEDCL shall be final.

## **J. FORFEITURE OF PERFORMANCE BANK GUARANTEE**

- a. Whenever any claim against the Bidder for the payment of a sum of money arises out of or under the contract, the EMPLOYER shall be entitled to recover such sum by encashing in part or whole the P.B.G. Bond submitted by the Bidder . In the event of the P.B.G. Bond being insufficient or if no other security has been taken from the Bidder, then the balance or the total sum recoverable as the case may be, shall be deducted from any sum then due or which at any time thereafter may become due to the Bidder. The Bidder shall pay to the EMPLOYER on demand any balance remaining due.
- b. In the event of any breach by the Bidder or any loss or damage occasioned by the EMPLOYER which in the opinion of the EMPLOYER has arisen, the decision where of shall be final and binding on the Bidder or in the event of the termination of the contract for any such breach, the P.B.G. Bond is liable to be forfeited. The decision of forfeiture by the EMPLOYER shall be final and binding on the Bidder.

## **K. PRICES**

1. The Bidder should submit their prices as per enclosed price bid format at Annexure – VI.
2. The Price quoted by the Bidder shall remain firm and binding during the Contract Period subject to the variations stipulated hereinafter. The break-up of Price with respect to the supply/service and the respective quantities for successful implementation shall be considered as indicative. The Bidder shall perform all his works as envisaged in the Agreement.
3. If the actual physical supplies and services are found more than those indicated by the Bidder in

the Price Schedule, the Bidder shall not be entitled for any additional amount from the Employer. However in the event of decrease in actual supplies/services, the Contract Price shall be adjusted for the decreased supplies/services.

4. Unless specified otherwise in the Employer's Requirements, the prices to be quoted are intended to provide for all work duly and properly completed in accordance with the General Conditions of Contract and Special Conditions of Contract.
5. All payments shall be made directly to the bidder on necessary certification by the Bidder and on compliance of contractual terms & conditions. No Letter of Credit is envisaged for Rupee payment.
6. In case of shortage/missing/damage/ failure of any product identified at any point of time within the period specified by the Contract including guarantee period, the agency shall supply/replace the same without any financial implication to the Employer. The taxes, duties, clearing & forwarding and other charges incurred by the Employer in this regard shall be recovered from the Bidder's pending bills and in case no bills are pending the same shall be made good by the Bidder. The Bidder shall accordingly submit the subsequent invoices.
7. The bidder shall stand guarantee for the overall performance of the contract including for the supplies made/work done and work to be done by their Bidder members. Towards this guarantee, the Bidder shall submit a performance BG/security deposit for 5% of the Contract Price as per tender Conditions.
8. Considering the progress of the works and in order to meet the Contract Schedule, the Contractor shall carry out the works on round the clock if required, duly complying the statutory and site requirements.
9. Any other activity necessary for the completion of the supply, installation, tests & commissioning up to guarantee period as per General Conditions of Contract, Special Conditions of Contract if any, and Specifications.
10. All procedures required under statutes, for availing any concessions under relevant tax laws shall be adhered to by the Contractor.
1. The bidder shall note that the prices quoted shall include all the items and services listed at Annexure - VI (Price bid format)

## **L. TAXES & DUTIES**

The quoted prices should be 'FIRM' inclusive of all of Govt. Statutory / levis / taxes & duties as applicable.

1. The estimated cost of GST chargeable to the Employer by the Contractor, wherever applicable, shall be shown separately in the Bidder's quotation,
2. The bidder should also note that the Employer will discharge its tax liability under the most beneficial scheme for availing the maximum cost advantage. Bidder should therefore take any GST to which they may be legally entitled into consideration while offering their quoted rates / prices.
3. Upward variation in GST if any applicable after opening of price bid/revised price/revision in price as the case may be (based on which the order on contract shall be placed) shall be reimbursed by the EMPLOYER subject to production of necessary documents by the Bidder. Similarly withdrawal/downward revision in variation in GST shall be adjusted in the price quoted and benefit shall be passed to the EMPLOYER. Variation of GST shall be reimbursed and no other variation shall be considered. Fresh taxes & levies, if any, as may be applicable on this contract, shall be reimbursable against documentary proof to be submitted by the Bidder. The bidder has to consider all taxes & duties applicable on this contract. Any omission, or non-inclusion, either declared or not declared, of any taxes and duties that are applicable at the

time of submission of price bid/revised price bid /revision in prices shall not be considered as a reason for reimbursement of such taxes and duties at a later date.

4. During tenure of the contract if any new taxes/duties/levies etc. are imposed or rates undergo changes, as notified by the Government and become applicable to the subject works, the same shall be reimbursed by the Employer on production of documentary evidence in respect of payment of the same. Similarly, benefits accruing to agency on account of withdrawal/reduction in any existing taxes and duties shall be passed on to the Employer.
5. Variation in GST after opening the Price Schedule and/or revised Price Schedule as the case may be (based on which the order on Contract shall be placed) shall be reimbursed by the Employer subject to production of necessary documentary evidence by the Contractor at the time of submission of bill. Similarly withdrawal/ downward revision in GST shall be adjusted in the price quoted and benefit shall be passed to Employer. However if the Work is delayed for the reasons attributable to the Employer and extension of the Time for Completion is granted, variation in Taxes and Duties enacted during Contractual completion/execution period, the adjustment in contract price shall be allowed within the extended period of the Contract. Similarly, if the Work is delayed for the reasons attributable to the Contractor, variations in Taxes and Duties will not be paid.
6. The Contractor shall bear and pay all the liabilities in respect of non-observance of all legal requirements as per various statutory provisions.
7. The adjustment in the Contract Price towards imposition of new taxes or abrogation of existing taxes shall be applicable only if the new tax is enacted or existing tax is abrogated within Contractual delivery/execution period. For any variation due to enactment of new tax or abrogation of existing tax after Contractual delivery / execution period, adjustment in the Contract Price shall not apply.
8. All formalities required under statutes, for availing any concessions under relevant tax laws shall be adhered to by the Bidder.

#### **M. DEDUCTION OF TAXES AT SOURCES**

1. Recovery at source towards income tax calculated at the rate prescribed from time to time under the Income Tax Act 1961 and other relevant sections of Income Tax Act shall be made from the bills of the Bidder and the amount so recovered shall be deposited with the Income Tax Department. Necessary TDS certificate to this effect will be issued to the Bidder in the prescribed pro-forma.
2. If any other taxes / duties are to be recovered at source as per government regulations from time to time the same shall be recovered from the bills payable to the Bidder. Necessary receipt to this effect will be issued to the Bidder in this regard.

#### **N. LIQUIDATED DAMAGES :**

1. The Bidder shall stand guarantee for the performance and output as envisaged in the tender specification
2. In case of a delay in the deliverables (milestones as per below table) within the period stipulated in the agreement, the Bidder shall be liable to pay, at the discretion of the competent authority of MSEDCL, the liquidated damages to MSEDCL up to ½ % + GST if applicable per week or part of week on the price, subject to a maximum ceiling of 10% reckoned on the total contract value. Due consideration may be given in the levy of liquidated damages for reasons absolutely beyond the control of the Bidder, for which documentary evidence shall be produced to the satisfaction of the competent authority of MSEDCL. The decision of MSEDCL undersigned shall be final and binding on Bidder.

At any time after the placement of this order if the Bidder fails to fulfill the obligations arising out of this order MSEDCL will have the right to get the work done from any other agency for completing the remaining work at Bidder's risk & cost.

The Liquidated Damages will be made applicable considering the Milestones agreed by the bidder as per Annexure – XI

Milestone for Three Phase Prepaid Meters	Qty. in Nos.	Timelines (Month wise)	% age penalty on Price
1	2	3	4
Supply	To be filled by the bidder	As per Cl. 2.5 of RFP	After the completion of timeline, LD @ 0.5% of committed lot value per week or part-thereof with maximum 10% of the contract value may be levied from the bill of the contractor
Installation	To be filled by the bidder	As per Cl. 2.5 of RFP	
FMS / Meter reading through AMR	To be filled by the bidder	Immediate subsequent month of installation of each meter.	

## O. TRANSFER OF OWNERSHIP

Ownership and the terms of usage of the Software and hardware, infrastructure and Materials supplied under the Contract shall be governed by Tender Conditions. After the contract period is over, infrastructure installed by the bidder such as data collection software, etc. shall be handed over to MSEDCL. All the infrastructure installed during contract period, should be in good working condition while handing over to MSEDCL. All the hardware and software installed during the contract period shall be treated as MSEDCL property. The vendor shall grant the purchaser a perpetual license to use the software without any additional payment or obligations to enter into a contract for maintenance or support.

## P. BILLING AND PAYMENT TERMS

Payment would be made in the following sequence:-

### **(a) Payment against Supply:**

- (i) 50% of the TP Prepaid meter cost for the supplied lot shall be paid after successful Inspection & delivery of the material at MSEDCL store location.
  - Payment of the Contract price will be paid through RTGS/NEFT within 60 days from the date of receipt of material in stores in good condition, against inspected lot quantity.
- (ii) 20% of the TP Prepaid meter cost shall be paid after successful Installation & uploading the data on billing system with 1<sup>st</sup> billing reading of consumer in MSEDCL MDAS system.
  - Will be paid through RTGS / NEFT within 45 days after confirmation of receipt of data through MDAS in consultation with IT & BR section.

### **(b) Payment against Installation:**

100% payment towards installation of TP Prepaid meter for the installed quantity shall be made after successful Installation & uploading the data on billing system with 1<sup>st</sup> billing reading of consumer after confirmation of receipt of data through MDAS in consultation with IT & BR section.

- Will be paid through RTGS/NEFT within 45 days after 1st billing reading of consumer after confirmation as above.

**(c) Payment for FMS / Reading through AMR and balance 30 % of meter cost :**

Monthly 100% payment towards consumers meter reading actually received in MSEDCL MDAS system (FMS) & 0.5 % of meter cost/month during the project duration of 5 years will be made after confirmation of receipt of monthly data through MDAS in consultation with IT & BR section on fulfillment of below.

- i. The Bidder shall submit monthly invoice as per agreed payment terms with supporting documents. All the deliverables completed and eligible for payment can be included. Payments will be made within 45 working days through account payee cheque or through RTGS only after submission of the bills and other documents which are correct in all respects for on account bills to the MSEDCL and as per availability of funds. Payment shall be released on submission of the bill with supporting documents and after deducting applicable taxes, penalty and other recoverable. Against deduction of statutory taxes, tax deduction certificates where ever applicable shall be issued at the end of the month.
- ii. FMS / Billing by the agency shall be done, purely on per reading basis only i.e. for no. of Meter readings downloaded through AMR. Taxes applicable, if any, such as GST or any other tax applicable from time to time shall be paid extra.
- iii. No separate charges will be paid to agency for integration of data collection software with MSEDCL central server i.e. MDAS
- iv. In case of non-receipt of readings through AMR, readings should be downloaded through optical port through MRI/HHT. The HHT/MRI reading instrument should be arranged by the bidder at their own cost.
- v. Penalty is applicable for readings not received through AMR within reading program as per annexure-VIII for SLA.
- vi. The bidder shall submit the duly signed, circle wise monthly invoices with details of sub-division wise and PC wise readings in triplicate along with reading statistics for readings of meters through AMR, at the end of each month to General Manager (F&A-SB), Prakashgad, Mumbai. The invoices submitted will be processed on the basis of meter reading available in the web based data collection software of the bidder.
- vii. For communication the cost of SIM card & recurring monthly charges shall be borne by MSEDCL.

**Q. WAIVER**

Failure of the EMPLOYER to insist upon strict performance of any terms and conditions of the contract will not be deemed a waiver of any rights or remedies that the EMPLOYER may have and will not be deemed a waiver of any subsequent default under the terms and conditions of the contract. No right or remedy of the EMPLOYER will be exclusive of any other right or remedy and EMPLOYER will have all the rights and remedies given under the contract and now or hereafter existing in law or by statute. The shipping or delivery by the Bidder or receiving of or payment by the EMPLOYER for the work under this contract will not be deemed a waiver of any rights for any prior failure by the Bidder to comply with any of the provisions of the contract.

**R. MEMBERS OF EMPLOYER NOT INDIVIDUALLY LIABLE**

No Director or official or employee of the EMPLOYER shall in any way be personally bound or



liable for the acts or obligations of the EMPLOYER under the contract or answerable for any default or omission in the observance or performance of the acts, matters or things which are herein contained. The Bidder shall not be entitled to any increase on the scheduled rates or any other rights or claims whatsoever by reason of any representation, explanation, statement or alleged understanding, promise or guarantees given or to have been given to him by any person.

## **S. TRANSPORTATION**

Bidder shall make his own arrangements for movement of human resources and equipment within and outside the sites/units/offices at the various locations covered by the Contract at his own cost.

## **T. SUPPLY, INSTALLATION OF THREE PHASE PREPAID METER AND IMPLEMENTATION OF FMS, BIDDER'S STAFF AND THEIR CONDUCT**

1. The Bidder on award of work shall deploy qualified professionals as designated in the scope of the Contract for implementing SUPPLY, INSTALLATION OF THREE PHASE PREPAID METER AND IMPLEMENTATION OF FMS.. At any time in the opinion of the MSEDCL, any additional, qualified, experienced engineer is considered necessary; they shall be deployed by the Bidder without any additional charge. The Bidder shall ensure to the satisfaction of the MSEDCL competent and efficient supervision of the consulting services.
2. If any of the Bidder's employee in the opinion of MSEDCL be guilty of any misconduct or be incompetent or insufficiently qualified or negligent in the performance of their duties or that in the opinion of the MSEDCL, undesirable for administrative or any other reasons, for such person(s) to be employed for providing consultancy services, then at the directions of the MSEDCL the Bidder shall at once remove such person (s) from the site(Works). Vacancy so created shall be immediately filled at the expense of the Bidder by a qualified and competent substitute. Should the Bidder be requested to repatriate any person or removed from this contract, he shall do so and shall bear all costs in connection therewith.
3. The Bidder shall be solely responsible for the proper behavior of his employees and staff employed by him/deputed by him to provide consultancy services. The Bidder shall exercise proper degree of control over them and in particular without prejudice to the said generality the Bidder shall be bound to prohibit/prevent any of his employees (as stipulated above) from trespassing or acting in anyway detrimental or prejudicial to the interest of the community or the properties or occupiers of land or properties in the neighborhood. In the event of such trespassing, the Bidder shall be responsible for all consequent claims or actions for damages or injury or any other grounds whatsoever. The decision of the MSEDCL upon any matter arising under this clause shall be final.
4. All Bidder's personnel entering the Employer's premises shall be properly identified by badges of a type acceptable to the EMPLOYER which must be worn at all times on the Employer's premises.
5. It is made clear that no relationship of employer and employee is created between the EMPLOYER and the Bidder's resident engineers, employees and no claim for employment of any such personnel shall be tenable or entertained

## **U. SECURITY AND SAFETY REGULATIONS**

The Bidder shall abide by all the safety and security regulations of the EMPLOYE Reinforce and promulgated from time to time and other statutory requirements.

## **V. EMPLOYEES PROVIDENT FUNDS AND MISCELLANEOUS PROVISIONS ACT**

1. The Bidder shall ensure strict compliance of provisions of the Employees' Provident Funds and Miscellaneous Provisions Act 1952 and the schemes framed there under so far as they are applicable to their establishments and agencies engaged by them. The Bidder also required indemnifying the EMPLOYER against any loss or claims or penal damages whatsoever resulting out of non-compliance on the part of the Bidder with the provisions of the aforesaid Act and the Schemes framed there under.
  2. The Bidder agrees to and does hereby accept full and exclusive liability for the compliance with all obligations imposed by Employees State Insurance Act, 1948, and the Bidder further agrees to defend, indemnify and hold Employer harmless from any liability or penalty which may be imposed by the Central, State or local authority by reason of any alleged violation by Bidder of the Employees' State Insurance Act, 1948 and also from all claims, suits or proceedings that may be brought against the Employer arising under, growing out of or by reason of the work provided for by the Contract whether brought by employees of the Bidder, by third parties or by Central or State Government authority or any political sub-division thereof.
  3. The Bidder agrees to file with the Employees State Insurance Corporation (ESI), the Declaration forms and all forms which may be required in respect of the Bidder's employee whose aggregate remuneration is within the specified limit and who is employed in the work provided or those covered by ESI Act and Employees Provident Funds (EPF) Sand Miscellaneous provisions Act 1952 under any amendment to the Act from time to time.
  4. In absence of ESI, bidder has to provide Workmen Compensation and medical Insurance (for accident arising out/during the course of employment) for all the employees engaged in the performance of this Contract.
  5. The Bidder agrees to maintain all records as required under the Act in respect of employees and payments. Any expenses incurred for the contributions, making contribution or maintaining records shall be to the Bidder's account.
  6. The Employer shall retain such sum as may be necessary from the total contract value until the Bidder shall furnish satisfactory proof that all contributions as required by the Employees State Insurance Act, 1948, have been paid.
- X. The Bidder shall conform in all respects with the provisions of any statutory regulations, ordinances or byelaws of any local or duly constituted authorities or public bodies which may be applicable from time to time to the consulting services work.

## **Y. LIENS**

If at any time there should be any evidence or any lien, claim for which the EMPLOYER might have become liable, which is chargeable to the Bidder, then the EMPLOYER may pay and discharge the same and deduct the amount so paid from any amount which may be or may become due and payable to the Bidder. If any lien or claim remain unsettled after all payments are made, the Bidder shall refund or pay to the EMPLOYER the cost such lien or claim including all payments and reasonable expenses. EMPLOYER reserves the right to the same.

## **Z. OTHER TERMS AND CONDITIONS**

1. The Bidder is required to enter into agreement after submission of Initial Security deposit.
2. Should the EMPLOYER at any time require the Bidder to do any work beyond what is provided

under this agreement, the Bidder shall undertake to do such additional work for an additional remuneration to be mutually agreed upon.

3. The EMPLOYER may make modifications/revisions/changes/deletions in the scope of work from time to time and the same shall be complied with by the Bidder without prejudice to his rights under the contract

#### **AA. PROFILES OF TEAMS**

The Bidder has to deploy a specialized and trained team for the successful and timely completion of the Project. The bidder shall submit the details of experience with proof.

#### **BB. TEMPORARY SUSPENSION**

MSEDCL may at any time temporarily suspend or stop the execution of the Contract or any part thereof by notice in writing to Contractor. All works so suspended or stopped shall be resumed by Contractor based on a schedule to be mutually agreed upon between MSEDCL and Contractor. In case of temporary suspension because of MSEDCL suitable compensation will be paid by MSEDCL on mutually agreed basis.

1. MSEDCL reserves to itself the right to withdraw from the tendering process or from any part thereof, to accept or reject any or all tenders, in full or any part, at any stage of process and / or to modify the process or any part thereof at any time thereof without assigning any reasons whatsoever. No financial obligation shall debit to MSEDCL in such an event. The Tenderers are advised to submit the tender strictly based on the terms and conditions and scope contained in the tender documents including corrigenda/amendments, if any, issued by MSEDCL prior to submission of tender. For corrigenda/amendment with financial implications, if any, issued by MSEDCL after submission of tender, but before opening of Price Bids, the Tenderers shall be entitled to amend their prices.
2. Bid documents shall comprise of various Annexure and Attachments as specified in Tender documents. In addition, any other document / instruction / amendments / Minutes of Meeting/revisions issued by the EMPLOYER to the bidder during pre-bid Conference or later till due date of submission of the offers, shall also be deemed to be integral part of the bid documents and order. Failure to furnish all the information required by the bidding document in every respect will be at bidder's risk.

**ANNEXURE -I**  
**“INDEMNITY BOND”**

UNDERTAKING TO BE SUBMITTED BY THE PARENT COMPANY SITUATED ABROAD IN CASE OF THE PARTICIPANT BIDDER WHO IS AN INDIAN BASED SUBSIDIARY ON GENERAL STAMP OF RUPEES 200/-

The Chief Engineer (MMD),  
Maharashtra State Electricity Distribution Co. Ltd.,  
Prakashgad,  
Bandra (E),  
Mumbai – 400 051.

Sub: Undertaking against Tender \_\_\_\_ for procurement of \_\_\_\_\_.

Dear Sir:

We, M/s. \_\_\_\_\_ having registered office at \_\_\_\_\_ are the Parent Company of M/s. \_\_\_\_\_ who have participated against your tender no. \_\_\_\_\_ for procurement of \_\_\_\_\_.

We have carefully read and have thoroughly understood and agree to the terms and conditions of the subject tender.

We hereby undertake that in case of placement of order against the subject tender on our subsidiary company, M/s. \_\_\_\_\_, in the event of we accept all the responsibilities and liabilities for supply of quality meters as per specification of the tender and execution of the contract. We further hereby undertake that we shall be responsible for any liability arising out of the contract placed on M/s. \_\_\_\_\_ and to pay MSEDCL on demand the sum of rupees as per agreement in the event of any breach of condition of the purchase order, loss and damage of the material till expiry of guarantee period as stipulated in the order. Our liability here under shall not be impaired or discharged by extension of time or variation or alteration made with or without our knowledge or consent by or between the parties to the said contract. This undertaking shall be valid and binding on us upto and including the execution and guarantee period of the order and shall not be terminable by notice or change in the constitution of any of the companies. In case of any dispute arising out of or in connection with this tender or contract, if concluded, the same shall be subject to the exclusive jurisdiction of the “Court in Mumbai (India).”

Yours faithfully,

(Authorized Signatory)

FOR \_\_\_\_\_

**ANNEXURE - II**  
**FORM OF AUTHORISED NOMINEE/ASSIGNEE**  
(To be submitted on the letter head of the foreign Bidder/Manufacturer)  
Date:

To,  
The Chief Engineer (MMD),  
Maharashtra State Electricity Distribution Co. Ltd.  
1<sup>st</sup> Floor, Prakashgad, Plot No. G-9,  
Bandra (East) Mumbai – 400 051.  
India

Subject:- Notification of invitation of bids against Tender No. -----  
For supply of Static Energy Meters of foreign origin.

Dear Sir,

This has reference to the Tender No. ----- for supply of Static Energy Meters. We M/s. ----- (foreign Bidder/Manufacturer) authorize our Assignee/Nominee in India M/s. ----- to participate against Tender No. ----- . We M/s. ----- -----(foreign Bidder/Manufacturer) hereby agree, confirm, adopt unconditionally to abide by the offer of M/s. ----- (Assignee/Nominee) for supply of Static Energy Meters.

Thanking you,

Your's Faithfully,

(Signature of the Authorized Signatory of foreign Bidder/Manufacturer)

(Name)

(Designation)

**ANNEXURE - III**

**UNDERTAKING CUM INDEMNITY BOND FOR POLYCARBONATE ENCLOSURE OF SINGLE  
PHASE METERS**

---

----- NOT APPLICABLE -----

**Annexure IV#(A) PROFORMA FOR BANK GUARANTEE FOR BID SECURITY (EMD)****To: Maharashtra State Electricity Distribution Company Limited***Represented by***Chief Engineer (MMD)**

Maharashtra State Electricity Distribution Co. Ltd.  
 "Prakashganga", First Floor, Plot No.C-19, E-Block,  
 Bandra Kurla Complex, Bandra (East),  
 Mumbai 400 051, India

**WHEREAS** *[name and address of Contractor]* (hereinafter called "the **Contractor**") has undertaken, in pursuance of Tender No., dated for Supply and installation of LT AC Three Phase 10-60 A Prepaid Static Energy Meters as per IS: 16444-2015 with communication module and implementation of FMS for Meter Reading of Ag. connections spread over entire state of Maharashtra, (hereinafter called "the **Contract**");

**AND WHEREAS** it has been stipulated by you in the said Contract that the Contractor shall furnish you with a Bank Guarantee by a recognized bank for the sum specified therein as security for compliance with his obligation in accordance with the Contract;

**AND WHEREAS** we have agreed to give the Contractor such a Bank Guarantee;

**NOW THEREFORE** we hereby affirm that we are the Guarantor and responsible to you, on behalf of the Contractor, up to a total of **Rs.-----/- (Rs. -----)** and we undertake to pay you, through our branch office at \_\_\_\_\_ *[Address of branch office at Mumbai, Maharashtra]*, upon your first written demand and without cavil or argument, any sum or sums within the limits of \_\_\_\_\_ *[amount of Guarantee]* as aforesaid without your needing to prove or to show grounds or reasons for your demand for the sum specified therein.

We hereby waive the necessity of your demanding the said debt from the Contractor before presenting us with the demand.

We further agree that no change or addition to or other modification of the terms of the Contract or of the Works to be performed there under or of any of the Contract documents which may be made between you and the Contractor shall in any way release us from any liability under this guarantee, and we hereby waive notice of any such change, addition or modification.

The bank guarantee will remain in force from date of issue till \_\_\_\_\_ (210 days from the Date of Issue of Tender). Any demand in respect thereto should reach the Bank not later than the specified date i.e. \_\_\_\_\_. (210 days from the Date of Issue of Tender).

The bank guarantee for bid security may be forfeited:

a) if the bidder withdraws its bid, except that written notice of the withdrawal of bid is received by the employer prior to the deadline for submission of bids; or

(b) if the bidder does not accept the correction of its bid price, pursuant to Tender Conditions; or

(c) if the bidder is determined, at any time prior to award of contract, to have engaged in corrupt or fraudulent practices as defined under tender in competing for the contract; or

(d) in the case of a successful bidder, if it fails within the specified time limit to:

(i) sign the Contract Agreement, or

(ii) furnish the required contract performance security

Yours truly,

Signature and seal of the Guarantor:

Name of Bank/Financial Institution:

Address:

Date:

\_\_\_\_\_

\_\_\_\_\_

**ANNEXURE IV (B) PROFORMA FOR SECURITY / PERFORMANCE BANK GUARANTEE**

(On Non-judicial paper for appropriate value)

To,

Maharashtra State Electricity Distribution Company Limited  
-----  
-----

Dear Sir,

In consideration of the Maharashtra State Electricity Distribution Company Limited,(herein after called 'the Company' which expression shall include its successors and assigns) having awarded to M/s. (Name).....(Constitution).....(address).....(herein after referred to as "The vendor" which expression shall wherever the subject or context so permits include its successors and assigns) a supply contract in terms inter alia, of the Company's purchase order No.....dated.....and the General and Special Purchase Conditions of the Company and upon the condition of vendor's furnishing security for the performance of the vendor's obligations and / or discharge of the vendor's liability under and/or in connection with the said supply contract upto a sum of Rs. (in figures).....Rs (in words).....only amounting to 5% (five percent) of the total contract value.

We, (Name).....(constitution).....(hereinafter called "the Bank" which expression shall include its successors and assigns) hereby jointly and severally undertake and guarantee to pay to the Company in---- (Currency) for the with on demand in writing and without protest or demur of any and all moneys any wise payable by the Vendor to the Company under in respect of or in connection with the said supply contract inclusive of all the Company's losses and expenses and other moneys anywise payable in respect to the above as specified in any notice of demand made by the Company to the Bank with reference to this Guarantee upto an aggregate limit of Rs (in figures).....Rs(in words).....only.

AND the Bank hereby agrees with the Company that

- i. This Guarantee/undertaking shall be a continuing guarantee and shall remain valid and irrevocable for all claims of the Company and liabilities of the vendor arising up to and until midnight of .....

This date shall be 6 months from the last date of guarantee period.

- ii. This Guarantee/ Undertaking shall be in addition to any other guarantee or security of what so ever that the Company may now or at any time otherwise have in relation to the vendor's obligation/liabilities under and/or connection with the said supply contract, and the Company shall have full authority to take recourse too reinforce this security in preference to the other security(ies) at its sole discretion, and no failure on the part of the Company in enforcing or requiring enforcement of any other security shall have the effect of releasing the Bank from its liability here under.

- iii. The Company shall be at liability without reference to the Bank and without effecting the full liability of the Bank hereunder to take any other security in respect of the vendor's obligations and/or liabilities under or in connection with the said supply contract and to vary the terms vis-à-vis the vendor of the said supply contractor to grant time and/or indulgence to the vendor or to reduce or to increase or otherwise vary the prices of the total contract value or to release or to for bear from enforcement all or any of the obligations of the vendor under the said supply contract and/or the remedies of the Company under any other security(ies) now or hereafter held by the



Company and no such dealing(s), variation(s), reduction(s), increase(s) or the indulgence(s) or arrangement(s) with the vendor or release or for bearance what so ever shall have the effect of releasing the Bank from its full liability to the Company hereunder or of prejudicing rights of the Company against the Bank.

- iv. This Guarantee/Undertaking shall not be determined by the liquidation or winding up or dissolution or change of constitution or insolvency of the vendor but shall in all respects and for all purposes be binding and operative until payment of all moneys payable to the Company in terms hereof.
- v. The Bank hereby waives all rights at any time inconsistent with the terms of the Guarantee/Undertaking and the obligations of the Bank in terms here of shall not be anywise affected or suspended by reason of any dispute or disputes having been raised by the vendor (whether or not pending before any Arbitrator, officer, Tribunal or Court) or any denial of liability by the vendor or any other order of communication what so ever by the vendor stopping or preventing or purporting to stop or prevent any payment by the Bank to the Company in terms hereof.
- vi. The amount stated in any notice of demand addressed by the Company to the Guarantor as liable to be paid to the Company by the vendor or as suffered or incurred by the Company on account of any losses or damages of costs, charges and or expenses shall as between the Bank and the Company be conclusive of the amount so liable to be paid to the Company or suffered or incurred by the Company, as the case may be and payable by the Guarantor to Company in terms hereof.

Yours faithfully,

(Signature)

NAME & DESIGNATION

NAME OF THE BANK

NOTES:

**Annexure V****Commitments of the Tenderer/Contractor**

- i.** The Tenderer /Contractor commit himself to take all measures necessary to prevent corruption. He commits himself to observe the following principles during his participation in the tender process and during the Contract execution;
  
- ii.** The Tenderer / Contractor will not directly or through any other person(s) or firm, offer, promise or give to the Principal, or to any of the Principal's employees involved in the tender process or the execution of the Contract or to any third person any material or immaterial benefit which he / she is not legally entitled to in order to obtain, in exchange, an advantage during the tender process or to vitiate the Principal's tender process or the execution of the Contract.
  
- iii.** The Tenderer / Contractor will not enter with other Tenderers into any illegal agreement or understanding, whether formal or informal. This applies in particular to prices, specifications, certifications, subsidiary contracts, submission or non-submission of bids or actions to restrict competitiveness or to vitiate the Principal's tender process or the execution of the Contract.
  
- iv.** The Tenderer / Contractor will not commit any criminal offence under the relevant Anti- corruption Laws of India; further, the Tenderer / Contractor will not use improperly, for purposes of competition or personal gain, or pass on to others, any information provided by the Principal as part of the business relationship, regarding plans, technical proposals and business details, including information contained or transmitted electronically.
  
- v.** The Tenderer / Contractor will, when presenting his bid, disclose any and all payments he has made, is committed to or intends to make to agents, brokers or any other intermediaries in connection with the award of the Contract.
  
- vi.** The Tenderer/ Contractor will not take, directly or indirectly, any steps which could unduly influence the functioning of EIM.
  
- vii.** The Tenderer / Contractor will not instigate third persons to commit offences outlined above or be an accessory to such offences.

## Annexure VI

## PRICE BID

(A) PRICE BID FOR THREE PHASE PREPAID METER										
Item No.	Description of material	Quantity required in nos.	Quantity offered in nos.	Break-up of F.O.R. Destination Price indicated in column no. (4)						
				Ex-works price including packing charges but excluding taxes & duties (In Rs.)	Freight charges (In Rs.)	Transit Insurance charges (In Rs.)	Integrated GST @---- % for outside state transaction (Ex-works price + Freight charges + Transit Insurance charges) (In Rs)	Central GST @---- % for within state transaction (Ex-works price + Freight charges + Transit Insurance charges) (In Rs)	State GST @---- % for within state transaction (Ex-works price + Freight charges + Transit Insurance charges) (In Rs)	F.O.R. Destination price per No. (In Rs.)
(1)	(2)	(3)	(4)	(5)	(6)	(7)	(8)	(9)	(10)	11=(5+6+7+8+9+10)
1	LTAC Three Phase 10 - 60 Amps Prepaid Static Energy Meter as per IS: 16444-2015 with Communication module (Item Code: 77009504464)	1,50,000								

(B) PRICE BID FOR SERVICES							
Item No.	Description of material	Quantity in Nos.	Quantity offered in Nos.	Charges / meter	GST / meter	Total / meter	Total
1	2	3	4	5	6	7 (5+6)	8 (4*7)
1	Installation of Three Phase Prepaid meter along with allied materials for Service Connections.	1,50,000					
2	FMS charges Per Meter Per Month	1,50,000					

Seal

Authorized Signature

Name and designation of Signatory

**Annexure VII**

**Format for No Deviation Form**

**Tender Name:**

**Tender No. :**

**CERTIFICATE FOR NO DEVIATION**

We, (Bidder's Name), hereby certify that there is no technical or commercial deviation from the Conditions mentioned in Tender Document and I am agreeing to all the terms and conditions mentioned in the Tender Specification.

Authorized Signatory with seal

Date:

Place:

**Annexure VIII**

**SERVICE LEVEL AGREEMENT**

1. Purpose of this Agreement

The purpose of this SLA is to clearly define the levels of service to be provided by Supplier to Purchaser for the duration of this contract or until this SLA has been amended. The benefits of this SLA are to:

- 1 Trigger a process that applies Purchaser and Supplier management attention to some aspect of performance only when that aspect drops below an agreed upon threshold, or target.
- 2 Makes explicit the performance related expectations on performance required by the Purchaser
- 3 Assist the Purchaser to control levels and performance of services provided by Supplier
- 4 This SLA is between Supplier and Purchaser.

2. Description of Services Provided

Supplier shall provide service as defined in Scope of Work, in accordance to the definitions and conditions as defined in this RFP.

2.1. Duration of SLA

This Service level agreement would be valid for entire period of contract. This SLA may be reviewed and revised according to the procedures detailed in "SLA Change Control".

2.2. Service Level Agreements & Targets:

This section is agreed to by Supplier and Purchaser as the key Supplier performance indicator for this engagement. The following section reflects the measurements to be used to track and report systems performance on a regular basis.

**a) The indicative SLA to be measured is as below:**

SLA Category	SLA	Measurement
End-to-end communication availability	99% of end-to end communication availability	Measured on the basis of average no. of non-communicating meters per month.

**Penalty for non-availability of readings:**

Readings (billing data) of meters should be downloaded daily, at least once and made available at data collection software by the bidder. Penalty will be calculated for missing number of days (for which readings are not downloaded) for each prepaid meter in a month. Percentage of readings for SLA will be calculated as per following formula:

$$\% \text{ of Readings for SLA} = \frac{\text{Sum of Prepaid Meter readings in a month (Considering one reading per day per meter)}}{\text{Total no. of Prepaid Meters installed} \times 30} \times 100$$

### Monthly Meter Reading Penalty for Three Phase Prepaid meters

Percentage of no. of Three Phase Prepaid meter readings (billing data) received through AMR and updated in data collection software per month	Penalty (Considering one reading daily per Prepaid meter through AMR in a month )
>= 90%	No penalty
>= 80% and < 90%	10% penalty on unit rate on missing no. of daily readings in a month.
>= 70% and < 80%	15 % penalty on unit rate on missing no. of daily readings in a month.
>= 50% and < 70%	20 % penalty on unit rate on missing no. of daily readings in a month.
< 50%	No Payment for a month

**Note: In case of non-communication between Prepaid meter and central server, agency should resolve the issue & establish communication between prepaid meter & server, within 72 hours.**

#### 2.3. Breach of SLA

In case the Supplier does not meet the service levels mentioned in this Section for three (3) continuous time-periods as specified in the relevant clause, the Purchaser will treat it as a case of breach of Service Level Agreement. The following steps will be taken in such a case:-

1. Purchaser issues a show cause notice to the Supplier.
2. Supplier should reply to the notice within three working days.
3. If the Purchaser authorities are not satisfied with the reply, the Purchaser will initiate termination process as described GCC.

#### 2.4. Exclusions

The Supplier will be exempted from any delays or slippages on SLA parameters arising out of reasons absolutely beyond the control of Supplier, such as force majeure events like natural calamities, flood, etc. and non-communication due to SIM card issues etc.. Documentary evidence shall be produced to the satisfaction of tender issuing authority by Supplier. Decision for exclusions of SLA will be taken by tender issuing authority.

#### 2.5. Monitoring and Auditing

Purchaser will review the performance of Supplier against the SLA parameters each month, or at any periodicity defined in the contract document. The review / audit report will form basis of any action relating to imposing penalty or breach of contract. Any such review / audit can be scheduled or unscheduled. The results will be shared with the Supplier as soon as possible. Purchaser reserves the right to appoint a third-party auditor to validate the SLA.

#### 2.6. Reporting Procedures

The Supplier's representative will prepare and distribute SLA performance reports in an agreed upon format by the 10th working day of subsequent month of the reporting period. The reports will include "actual versus target" SLA performance, a variance analysis and discussion of appropriate issues or significant events. Performance reports will be distributed to the Purchaser's IT Team.

#### 2.7. Issue Management Procedures

##### a. General

This process provides an appropriate management structure for the orderly consideration and resolution of business and operational issues in the event that quick consensus is not reached between Purchaser and Supplier. It is expected that this pre-defined process will only be used on an exception basis if issues are not resolved at lower management levels.

##### b. Issue Management Process

- Either Purchaser or Supplier may raise an issue by documenting the business or technical problem, which presents a reasonably objective summary of both points of view and identifies specific points of disagreement with possible solutions.

- Purchaser and the Supplier's representative will determine which committee or executive level should logically be involved in resolution.
- A meeting or conference call will be conducted to resolve the issue in a timely manner. The documented issues will be distributed to the participants at least 24 hours prior to the discussion if the issue is not an emergency requiring immediate attention.
- Management of Purchaser and Supplier will develop a temporary, if needed, and the permanent solution for the problem at hand. The Supplier will then communicate the resolution to all interested parties.
- In the event a significant business issue is still unresolved, the arbitration procedures described in the Contract will be used.

## 2.8. SLA Change Control

### a. General

It is acknowledged that this SLA may change as Purchaser's business needs evolve over the course of the contract period. As such, this document also defines the following management procedures:

1. A process for negotiating changes to the SLA.
2. An issue management process for documenting and resolving particularly difficult issues.
3. Purchaser and Supplier management escalation process to be used in the event that an issue is not being resolved in a timely manner.

Any changes to the levels of service provided during the term of this agreement will be requested, documented and negotiated in good faith by both parties. Either party can request a change. Changes will be documented as an addendum to this document and consequently the contract.

### b. SLA Change Process

Both the parties may amend this SLA by mutual agreement in accordance. Changes can be proposed by either party. Normally the forum for negotiating SLA changes will be Purchaser's monthly review meetings.

### c. Version Control

All negotiated SLA changes will require changing the version control number. As appropriate, minor changes may be accumulated for periodic release (e.g. every quarter) or for release when a critical threshold of change has occurred.

## 2.9. Management Escalation Procedures

The purpose of this escalation process is to provide a quick and orderly method of notifying both parties that an issue is not being successfully resolved at the lowest possible management level. Implementing this procedure ensures that purchaser and Supplier management are communicating at the appropriate levels. Escalation should take place on an exception basis and only if successful issue resolution cannot be achieved in a reasonable time frame.

1. All issues would be raised to the project management team, which is completely responsible for the day to day aspects of the implementation. The project management team shall classify the issues based on their severity level and resolve them within appropriate timelines.
2. If project management team is unable to resolve an issue, the issue would be escalated to the top management with options/ risks detailed for decision. Purchaser's Top management will make decisions based on the options/ risks presented by Purchaser.
3. In case one or both the parties are unsatisfied with the decision of the top management of the Purchaser, the dispute will be resolved as specified in GCC.

2.10. Responsibility

The bidder shall be responsible for roles and responsibilities with respect to the Requisite Services. Further, terms & conditions mentioned in this RFP shall be binding on bidder.

2.11. Signature Page

IN WITNESS WHEREOF, the parties hereto have caused this Service Level Agreement to be executed by their respective authorized representatives as of the date first written above.

<b>Supplier</b>	<b>Purchaser</b>
Signature	Signature
Name	Name
Address	Designation
Company	Utility: Maharashtra State Electricity Distribution Co. Ltd.
Date	Date



**Annexure IX****WORKING MANUAL**

For smooth execution of project, procedures defined as below are to be strictly followed:

<b>Sr. No.</b>	<b>Description of activity</b>	<b>Responsibility</b>	<b>No. of working days</b>
1	Offering of material for inspection.	Supplier	As per Milestone
2	Inspection of meters for each lot at supplier's factory location.	MM Dept.	Within 3 working days of date of readiness of meters
3	After successful completion of inspection dispatching the meters to MSEDCL's store location.	Supplier	Within 10 working days
4	Information of receipt of meters to MM Dept.	Respective Store in charge	Same day
5	Issuance of RST letter	MM Dept.	2 working days
6	RST of supplied stock and information to MMD/concern store in charge	Testing / O&M division	2 working days
7	To convey RST report to remaining consignee stores for acceptance / rejection	Respective Store in charge	Same day
8	Creation of SR notes and forward to HO (SB Section) for payment	Respective Store in charge	Immediately.
9	Testing and sealing of meters at MSEDCL's office	Concern division office	Immediately
10	Handing over of priority list to replace the consumer meters	Respective Circle/Division/Sub Dn. / Section.	Immediately.
11	To arrange for shut down for installation of new meters	MSEDCL employee	Immediately after intimation by suppliers installation team.
12	Installation of meters at consumers site by supplier and sealing of terminal cover	Suppliers installation team, MSEDCL employee to	Immediately as per Milestone.
13	Providing SIM Card under umbrella scheme of MSEDCL for AMR directly to concerned supplier on requisition from supplier	IT section, Corporate Office	Immediately
14	To provide 1 <sup>st</sup> reading of newly installed meter to MSEDCL MDAS system through AMR	Supplier	As per Milestone
15	To provide FMS for period of 5 years through AMR.	Supplier	As per SLA
16	To handover the complete infrastructure involved in project in good condition to MSEDCL after completion of contract period of 5 years for reading.	Supplier	After successful completion of contract period of 5 years for reading.

**Annexure X****Check List**

We confirm that we have gone through the bid document and as instructed in the document, we hereby submit the following documents to form the bid:

<b>Sr. No.</b>	<b>Name of document</b>	<b>Whether submitted Yes/ No</b>	<b>File Name*</b>	<b>Page No</b>
1.	Annexure – I : Indemnity Bond for Foreign Bidder / Manufacturer			
2.	Annexure –II : For Authorized Assignee / Nominee in case of Foreign Bidder			
3.	Annexure –III : Indemnity Bond for Polycarbonate Meter Enclosure			
4.	Annexure –IV (A) : Proforma for Bid Security (EMD) Annexure –IV (B) : Proforma for Security / Performance Bank Guarantee			
5.	Annexure –V : Commitments of tenderer / contractor			
6.	Annexure –VI : Price Bid Format			
7.	Annexure –VII : No Deviation Proforma			
8.	Annexure –VIII : Proforma for Service Level Agreement (SLA)			
9.	Annexure –X : Check list			
10.	Annexure –XI : Milestone			
11.	Annexure – XII : Offered quantity			

**Any other information/documents required as per RFP.**

**Annexure XI****MILESTONES**

Milestone for Three Phase Prepaid Meters	Qty. in Nos.	Timelines (Month wise)	% age penalty on Price
1	2	3	4
Supply	To be filled by the bidder	As per Cl. 2.5 of RFP	After the completion of timeline, LD @ 0.5% of committed lot value per week or part-thereof with maximum 10% of the contract value may be levied from the bill of the contractor
Installation	To be filled by the bidder	As per Cl. 2.5 of RFP	
FMS / Meter reading through AMR	To be filled by the bidder	Immediate subsequent month of installation of each meter.	

**Annexure XII****Offered Quantity**

Quantity Offered at Column No. 4 of Annexure-'VI' (Price Schedule-A):

Sr. No.	Item Code	Material Description	Quantity Tendered in Nos.	Quantity Offered at Column No. 4 of Annexure-'VI' (Price Schedule-A) in Nos.
1	2	3	4	5
1	77009504464	LTAC Three Phase 10 - 60 Amps Prepaid Static Energy Meter as per IS: 16444-2015 with Communication module	1,50,000	

**Annexure XIII**

List of Three Phase Prepaid Meters: (Zone/Circle wise Summary)  
(As attached herewith)

Maharashtra State Electricity Distribution Company Limited  
SUMMARY OF AG CONNECTIONS RELEASED UNDER HVDS SCHEME

AG CONNECTIONS RELEASED UNDER HVDS SCHEME																		
REGION	ZONE	CIRCLE	TOTAL FREEZE LT AG PAID PENDING UPTO 31.03.18 (A)=C+D+E+F+G+H+I+J+K	TOTAL AG PP HAVING DTC ASSIGNED FOR HVDS (B)	Upto 3 HP	3 HP To 5 HP	5 HP To 7.5 HP	7.5 HP To 10 HP	Above 10 HP	Total (C)	AG RELEASED OTHER THAN HVDS SCHEME FROM AG PP HAVING DTC ASSIGNED FOR HVDS (D)	AG RELEASED OTHER THAN HVDS SCHEME WHERE DTC NOT ASSIGNED FOR HVDS (E)	TOTAL DELETED PP (F)	APPLIED FOR AG SOLAR (G)	TARIFF CHANGE D TO OTHER CATEGORY (LIVE) (H)	TARIFF CHANGE D TO OTHER CATEGORY (PP)(I)	TOTAL BALANCE PP FROM AG PP HAVING DTC ASSIGNED FOR HVDS (J)	TOTAL BALANCE PP WHERE DTC NOT ASSIGNED FOR HVDS (K)
AURANGABAD REGION	AURANGABAD ZONE	AURANGABAD (U) CIRCLE	6	0	0	0	0	0	0	0	0	5	0	0	1	0	0	0
AURANGABAD REGION	AURANGABAD ZONE	AURANGABAD CIRCLE	10809	6536	640	2042	126	17	2	2827	55	3392	438	78	100	0	3353	566
AURANGABAD REGION	AURANGABAD ZONE	JALNA CIRCLE	12930	10470	1199	2582	102	18	4	3905	424	1869	144	427	46	0	5628	487
<b>AURANGABAD REGION</b>	<b>AURANGABAD ZONE</b>		<b>23745</b>	<b>17006</b>	<b>1839</b>	<b>4624</b>	<b>228</b>	<b>35</b>	<b>6</b>	<b>6732</b>	<b>479</b>	<b>5266</b>	<b>582</b>	<b>505</b>	<b>147</b>	<b>0</b>	<b>8981</b>	<b>1053</b>
AURANGABAD REGION	LATUR ZONE, LATUR	BEED CIRCLE	9952	8220	1326	1250	74	80	1	2731	896	1602	42	104	34	0	4474	69
AURANGABAD REGION	LATUR ZONE, LATUR	LATUR CIRCLE	6068	4641	474	2202	76	132	8	2892	13	1069	24	7	14	0	1728	321
AURANGABAD REGION	LATUR ZONE, LATUR	OSMANBAD CIRCLE	8483	7084	176	2256	48	66	3	2549	1	826	136	55	49	0	4372	495
<b>AURANGABAD REGION</b>	<b>LATUR ZONE, LATUR</b>		<b>24503</b>	<b>19945</b>	<b>1976</b>	<b>5708</b>	<b>198</b>	<b>278</b>	<b>12</b>	<b>8172</b>	<b>910</b>	<b>3497</b>	<b>202</b>	<b>166</b>	<b>97</b>	<b>0</b>	<b>10574</b>	<b>885</b>
AURANGABAD REGION	NANDED ZONE	HINGOLI CIRCLE	5349	4941	96	3241	205	83	1	3626	0	242	6	50	3	0	1294	128
AURANGABAD REGION	NANDED ZONE	NANDED CIRCLE	7428	6423	1246	1871	102	125	12	3356	15	554	32	24	34	0	3011	402
AURANGABAD REGION	NANDED ZONE	PARBHANI CIRCLE	4532	4066	465	1836	107	63	6	2477	0	263	7	109	17	0	1524	135
<b>AURANGABAD REGION</b>	<b>NANDED ZONE</b>		<b>17309</b>	<b>15430</b>	<b>1807</b>	<b>6948</b>	<b>414</b>	<b>271</b>	<b>19</b>	<b>9459</b>	<b>15</b>	<b>1059</b>	<b>45</b>	<b>183</b>	<b>54</b>	<b>0</b>	<b>5829</b>	<b>665</b>
<b>AURANGABAD REGION</b>			<b>65557</b>	<b>52381</b>	<b>5622</b>	<b>17280</b>	<b>840</b>	<b>584</b>	<b>37</b>	<b>24363</b>	<b>1404</b>	<b>9822</b>	<b>829</b>	<b>854</b>	<b>298</b>	<b>0</b>	<b>25384</b>	<b>2603</b>
KOKAN REGION	BHANDUP (U) ZONE	PEN CIRCLE	524	118	71	19	4	1	0	95	1	244	22	2	99	0	14	47
KOKAN REGION	BHANDUP (U) ZONE	WASHI CIRCLE	9	0	0	0	0	0	0	0	0	7	1	0	1	0	0	0
<b>KOKAN REGION</b>	<b>BHANDUP (U) ZONE</b>		<b>533</b>	<b>118</b>	<b>71</b>	<b>19</b>	<b>4</b>	<b>1</b>	<b>0</b>	<b>95</b>	<b>1</b>	<b>251</b>	<b>23</b>	<b>2</b>	<b>100</b>	<b>0</b>	<b>14</b>	<b>47</b>
KOKAN REGION	JALGAON ZONE	DHULE CIRCLE	5910	4715	963	371	81	98	10	1523	51	891	24	1	3	0	3132	285
KOKAN REGION	JALGAON ZONE	JALGAON CIRCLE	9969	6664	2122	994	230	363	105	3814	10	2668	455	27	30	0	2674	291
KOKAN REGION	JALGAON ZONE	NANDURBAR CIRCLE	4180	2320	403	1183	191	116	5	1898	10	1502	197	11	15	0	404	143
<b>KOKAN REGION</b>	<b>JALGAON ZONE</b>		<b>20059</b>	<b>13699</b>	<b>3488</b>	<b>2548</b>	<b>502</b>	<b>577</b>	<b>120</b>	<b>7235</b>	<b>71</b>	<b>5061</b>	<b>676</b>	<b>39</b>	<b>48</b>	<b>0</b>	<b>6210</b>	<b>719</b>
KOKAN REGION	KALYAN ZONE	KALYAN CIRCLE - II	274	103	23	6	1	1	0	31	1	118	9	3	36	0	67	9
KOKAN REGION	KALYAN ZONE	PALGHAR (MINI) CIRCLE	572	236	53	48	0	0	0	101	1	185	80	4	32	0	112	57
KOKAN REGION	KALYAN ZONE	VASAI CIRCLE	133	30	17	0	0	0	0	17	0	70	4	1	22	0	13	6
<b>KOKAN REGION</b>	<b>KALYAN ZONE</b>		<b>979</b>	<b>369</b>	<b>93</b>	<b>54</b>	<b>1</b>	<b>1</b>	<b>0</b>	<b>149</b>	<b>2</b>	<b>373</b>	<b>93</b>	<b>8</b>	<b>90</b>	<b>0</b>	<b>192</b>	<b>72</b>
KOKAN REGION	KOKAN ZONE,RATNAGIRI	RATNAGIRI CIRCLE	949	192	117	24	2	2	0	145	5	441	137	29	49	0	0	143
KOKAN REGION	KOKAN ZONE,RATNAGIRI	SINDUDURG CIRCLE	1534	563	27	12	2	0	0	41	5	724	112	16	44	0	470	122
<b>KOKAN REGION</b>	<b>KOKAN ZONE,RATNAGIRI</b>		<b>2483</b>	<b>755</b>	<b>144</b>	<b>36</b>	<b>4</b>	<b>2</b>	<b>0</b>	<b>186</b>	<b>10</b>	<b>1165</b>	<b>249</b>	<b>45</b>	<b>93</b>	<b>0</b>	<b>470</b>	<b>265</b>
KOKAN REGION	NASIK ZONE	A-NAGAR CIRCLE	14184	8132	2298	2246	200	254	62	5060	636	3424	535	8	202	0	2272	2047
KOKAN REGION	NASIK ZONE	MALEGAON CIRCLE	12739	9750	1521	1808	1480	71	16	4896	1201	2081	574	7	10	0	3246	724
KOKAN REGION	NASIK ZONE	Malegaon DF Circle	20	16	0	0	0	0	0	0	0	0	0	0	0	0	16	4
KOKAN REGION	NASIK ZONE	NASIK (U) CIRCLE	6564	4003	1046	1093	52	13	0	2204	462	2236	393	9	123	0	993	144
<b>KOKAN REGION</b>	<b>NASIK ZONE</b>		<b>33507</b>	<b>21901</b>	<b>4865</b>	<b>5147</b>	<b>1732</b>	<b>338</b>	<b>78</b>	<b>12160</b>	<b>2299</b>	<b>7741</b>	<b>1502</b>	<b>24</b>	<b>335</b>	<b>0</b>	<b>6527</b>	<b>2919</b>
<b>KOKAN REGION</b>			<b>57561</b>	<b>36842</b>	<b>8661</b>	<b>7804</b>	<b>2243</b>	<b>919</b>	<b>198</b>	<b>19825</b>	<b>2383</b>	<b>14591</b>	<b>2543</b>	<b>118</b>	<b>666</b>	<b>0</b>	<b>13413</b>	<b>4022</b>
NAGPUR REGION	AKOLA ZONE	AKOLA CIRCLE	7977	4489	758	1673	253	253	3	2940	15	2847	113	27	117	0	1518	400
NAGPUR REGION	AKOLA ZONE	BULDHANA CIRCLE	10952	6111	1962	1252	98	129	12	3453	669	4175	105	66	162	0	1907	415
NAGPUR REGION	AKOLA ZONE	WASHIM CIRCLE	7802	4685	1620	1123	183	216	14	3156	108	2671	17	36	27	0	1398	389
<b>NAGPUR REGION</b>	<b>AKOLA ZONE</b>		<b>26731</b>	<b>15285</b>	<b>4340</b>	<b>4048</b>	<b>534</b>	<b>598</b>	<b>29</b>	<b>9549</b>	<b>792</b>	<b>9693</b>	<b>235</b>	<b>129</b>	<b>306</b>	<b>0</b>	<b>4823</b>	<b>1204</b>
NAGPUR REGION	AMARAVATI ZONE	AMARAVATI CIRCLE	8496	4049	762	1385	275	197	3	2622	18	3874	43	60	94	0	1384	401
NAGPUR REGION	AMARAVATI ZONE	YAVATMAL CIRCLE	8385	6502	2507	1321	58	63	16	3965	60	1076	114	84	74	0	2356	656
<b>NAGPUR REGION</b>	<b>AMARAVATI ZONE</b>		<b>16881</b>	<b>10551</b>	<b>3269</b>	<b>2706</b>	<b>333</b>	<b>260</b>	<b>19</b>	<b>6587</b>	<b>78</b>	<b>4950</b>	<b>157</b>	<b>144</b>	<b>168</b>	<b>0</b>	<b>3740</b>	<b>1057</b>
NAGPUR REGION	CHANDRAPUR ZONE	CHANDRAPUR CIRCLE	3539	2941	1819	498	23	9	0	2349	29	396	40	74	13	0	527	111
NAGPUR REGION	CHANDRAPUR ZONE	GADCHIROLI CIRCLE	2973	1588	1307	144	0	0	0	1451	25	1233	23	47	13	0	98	83
<b>NAGPUR REGION</b>	<b>CHANDRAPUR ZONE</b>		<b>6512</b>	<b>4529</b>	<b>3126</b>	<b>642</b>	<b>23</b>	<b>9</b>	<b>0</b>	<b>3800</b>	<b>54</b>	<b>1629</b>	<b>63</b>	<b>121</b>	<b>26</b>	<b>0</b>	<b>625</b>	<b>194</b>
NAGPUR REGION	GONDIA ZONE	BHANDARA CIRCLE	3837	3317	2352	35	2	1	0	2390	20	417	9	39	9	0	875	78
NAGPUR REGION	GONDIA ZONE	GONDIA CIRCLE	2725	2060	1834	24	2	2	0	1862	10	531	3	19	67	0	176	57
<b>NAGPUR REGION</b>	<b>GONDIA ZONE</b>		<b>6562</b>	<b>5377</b>	<b>4186</b>	<b>59</b>	<b>4</b>	<b>3</b>	<b>0</b>	<b>4252</b>	<b>30</b>	<b>948</b>	<b>12</b>	<b>58</b>	<b>76</b>	<b>0</b>	<b>1051</b>	<b>135</b>
NAGPUR REGION	NAGPUR ZONE	NAGPUR (R) CIRCLE	4243	3418	1875	425	31	164	7	2502	2	477	19	81	26	0	881	255

**Maharashtra State Electricity Distribution Company Limited**  
**SUMMARY OF AG CONNECTIONS RELEASED UNDER HVDS SCHEME**

AG CONNECTIONS RELEASED UNDER HVDS SCHEME																		
REGION	ZONE	CIRCLE	TOTAL FREEZE LT AG PAID PENDING UPTO 31.03.18 (A)=C+D+E+F+G+H+I+J+K	TOTAL AG PP HAVING DTC ASSIGNED FOR HVDS (B)	Upto 3 HP	3 HP To 5 HP	5 HP To 7.5 HP	7.5 HP To 10 HP	Above 10 HP	Total (C)	AG RELEASED OTHER THAN HVDS SCHEME FROM AG PP HAVING DTC ASSIGNED FOR HVDS (D)	AG RELEASED OTHER THAN HVDS SCHEME WHERE DTC NOT ASSIGNED FOR HVDS (E)	TOTAL DELETED PP (F)	APPLIED FOR AG SOLAR (G)	TARIFF CHANGE D TO OTHER CATEGORY (LIVE) (H)	TARIFF CHANGE D TO OTHER CATEGORY (PP)(I)	TOTAL BALANCE PP FROM AG PP HAVING DTC ASSIGNED FOR HVDS (J)	TOTAL BALANCE PP WHERE DTC NOT ASSIGNED FOR HVDS (K)
NAGPUR REGION	NAGPUR ZONE	NAGPUR (U) CIRCLE	293	183	67	27	2	0	0	96	0	45	9	12	13	0	76	42
NAGPUR REGION	NAGPUR ZONE	WARDHA CIRCLE	3244	2107	952	613	41	10	0	1616	7	1001	23	28	28	0	459	82
NAGPUR REGION	NAGPUR ZONE		7780	5708	2894	1065	74	174	7	4214	9	1523	51	121	67	0	1416	379
<b>NAGPUR REGION</b>			<b>64466</b>	<b>41450</b>	<b>17815</b>	<b>8520</b>	<b>968</b>	<b>1044</b>	<b>55</b>	<b>28402</b>	<b>963</b>	<b>18743</b>	<b>518</b>	<b>573</b>	<b>643</b>	<b>0</b>	<b>11655</b>	<b>2969</b>
PUNE REGION	BARAMATI ZONE	BARAMATI CIRCLE	7539	5166	2533	933	131	184	66	3847	18	2082	101	29	97	0	1261	104
PUNE REGION	BARAMATI ZONE	SATARA CIRCLE	13254	10110	3331	2087	115	313	61	5907	260	2809	127	36	104	0	3764	247
PUNE REGION	BARAMATI ZONE	SOLAPUR CIRCLE	15619	10430	601	4631	351	122	32	5737	1690	3987	161	6	206	0	2917	915
<b>PUNE REGION</b>	<b>BARAMATI ZONE</b>		<b>36412</b>	<b>25706</b>	<b>6465</b>	<b>7651</b>	<b>597</b>	<b>619</b>	<b>159</b>	<b>15491</b>	<b>1968</b>	<b>8878</b>	<b>389</b>	<b>71</b>	<b>407</b>	<b>0</b>	<b>7942</b>	<b>1266</b>
PUNE REGION	KOLHAPUR ZONE	KOLHAPUR CIRCLE	8567	4579	765	1213	74	401	119	2572	133	3679	203	61	66	1	1760	92
PUNE REGION	KOLHAPUR ZONE	SANGLI CIRCLE	16474	9438	1346	2758	94	131	20	4349	56	6050	490	20	157	0	4912	440
<b>PUNE REGION</b>	<b>KOLHAPUR ZONE</b>		<b>25041</b>	<b>14017</b>	<b>2111</b>	<b>3971</b>	<b>168</b>	<b>532</b>	<b>139</b>	<b>6921</b>	<b>189</b>	<b>9729</b>	<b>693</b>	<b>81</b>	<b>223</b>	<b>1</b>	<b>6672</b>	<b>532</b>
PUNE REGION	PUNE ZONE	GANESHKHIND (U) CIRCLE	31	2	0	0	0	0	0	0	0	21	2	0	8	0	0	0
PUNE REGION	PUNE ZONE	PUNE (R) CIRCLE	3584	2424	558	224	34	36	19	871	75	695	129	37	56	0	1346	375
PUNE REGION	PUNE ZONE	RASTAPETH (U) CIRCLE	5	1	1	0	0	0	0	1	0	3	0	0	1	0	0	0
<b>PUNE REGION</b>	<b>PUNE ZONE</b>		<b>3620</b>	<b>2427</b>	<b>559</b>	<b>224</b>	<b>34</b>	<b>36</b>	<b>19</b>	<b>872</b>	<b>75</b>	<b>719</b>	<b>131</b>	<b>37</b>	<b>65</b>	<b>0</b>	<b>1346</b>	<b>375</b>
<b>PUNE REGION</b>			<b>65073</b>	<b>42150</b>	<b>9135</b>	<b>11846</b>	<b>799</b>	<b>1187</b>	<b>317</b>	<b>23284</b>	<b>2232</b>	<b>19326</b>	<b>1213</b>	<b>189</b>	<b>695</b>	<b>1</b>	<b>15960</b>	<b>2173</b>
<b>STATE TOTAL</b>			<b>252657</b>	<b>172823</b>	<b>41233</b>	<b>45450</b>	<b>4850</b>	<b>3734</b>	<b>607</b>	<b>95874</b>	<b>6982</b>	<b>62482</b>	<b>5103</b>	<b>1734</b>	<b>2302</b>	<b>1</b>	<b>66412</b>	<b>11767</b>

MATERIAL SPECIFICATIONS CELL

TECHNICAL SPECIFICATION

OF

LT AC THREE PHASE 10 - 60 AMPS PREPAID STATIC  
ENERGY METER AS PER IS: 16444-2015 WITH  
COMMUNICATION MODULE



**TABLE OF CONTENTS**

<b>1.00</b>	<b>SCOPE .....</b>	<b>3</b>
<b>2.00</b>	<b>SERVICE CONDITIONS .....</b>	<b>3</b>
<b>3.00</b>	<b>APPLICABLE STANDARDS .....</b>	<b>4</b>
<b>4.00</b>	<b>SYSTEM ARCHITECTURE .....</b>	<b>4</b>
<b>5.00</b>	<b>GENERAL TECHNICAL REQUIREMENTS .....</b>	<b>6</b>
<b>6.00</b>	<b>CONSTRUCTION.....</b>	<b>7</b>
<b>7.00</b>	<b>METERING PROTOCOL .....</b>	<b>15</b>
<b>8.00</b>	<b>TOD TIMING.....</b>	<b>15</b>
<b>9.00</b>	<b>MAXIMUM DEMAND INTEGRETION PERIOD .....</b>	<b>16</b>
<b>10.00</b>	<b>MD RESET.....</b>	<b>16</b>
<b>11.00</b>	<b>WEB BASED PREPAID APPLICATION.....</b>	<b>16</b>
<b>12.00</b>	<b>PREPAID ENGINE .....</b>	<b>21</b>
<b>13.00</b>	<b>PREPAID AND CONNECT/DISCONNECT FEATURES .....</b>	<b>22</b>
<b>14.00</b>	<b>TAMPER&amp; FRAUD MONITORING FEATURES:.....</b>	<b>22</b>
<b>15.00</b>	<b>DISPLAY OF MEASURED VALUES .....</b>	<b>26</b>
<b>16.00</b>	<b>BILLING DATA,BILLING HISTORY, LOAD SURVEY &amp; TAMPER DATA ...</b>	<b>30</b>
<b>17.00</b>	<b>DEMONSTRATION .....</b>	<b>33</b>
<b>18.00</b>	<b>CONNECTION DIAGRAM AND TERMINAL MARKINGS .....</b>	<b>34</b>
<b>20.00</b>	<b>MARKING OF METER .....</b>	<b>34</b>
<b>21.00</b>	<b>TESTS .....</b>	<b>34</b>
<b>22.00</b>	<b>GUARANTEED TECHNICAL PARTICULARS .....</b>	<b>37</b>
<b>23.00</b>	<b>TENDER SAMPLE .....</b>	<b>37</b>
<b>24.00</b>	<b>PREDESPATCH INSPECTIONS .....</b>	<b>38</b>
<b>25.00</b>	<b>INSPECTION AFTER RECEIPT AT STORES (RANDOM SAMPLE TESTING)</b>	<b>38</b>
<b>26.00</b>	<b>TRAINING.....</b>	<b>39</b>
<b>27.00</b>	<b>GUARANTEE.....</b>	<b>39</b>
<b>28.00</b>	<b>PACKING .....</b>	<b>39</b>
<b>29.00</b>	<b>QUALITY CONTROL .....</b>	<b>40</b>
<b>30.00</b>	<b>MINIMUM TESTING FACILITIES .....</b>	<b>40</b>
<b>31.00</b>	<b>MANUFACTURING ACTIVITIES .....</b>	<b>41</b>
<b>32.00</b>	<b>QUALITY ASSURANCE PLAN .....</b>	<b>44</b>
<b>33.00</b>	<b>COMPONENT SPECIFICATION .....</b>	<b>44</b>
<b>34.00</b>	<b>SCHEDULES .....</b>	<b>44</b>
	<b>ANNEXURE-I .....</b>	<b>45</b>
	<b>ANNEXURE-II .....</b>	<b>47</b>
	<b>SCHEDULE 'A' .....</b>	<b>51</b>

---

**TECHNICAL SPECIFICATION OF THREE PHASE 10-60 AMPS PREPAID METER**

---

**1.00 SCOPE**

This specification covers the design, engineering, manufacture, assembly, stage testing, inspection and testing before dispatch and delivery at designated stores of ISI marked LT AC 10 - 60 Amps AMR compatible Prepaid Static LCD Three Phase Energy Meter of class 1.0 accuracy with communication module confirming to IS: 16444 / 2015 of the latest version suitable for measurement of Energy (kWh &kVAh) and Demand (kVA MD) in Three phase, Four wire system of LT three phase consumers.

The meter shall conform in all respects to high standards of engineering, design and workmanship and shall be capable of performing in continuous commercial operation, in a manner acceptable to purchaser, who will interpret the meaning of drawings and specification and shall have the power to reject any work or material which, in his judgment is not in accordance therewith. The offered material shall be complete with all components necessary for their effective and trouble free operation. Such components shall be deemed to be within the scope of Bidder's supply irrespective of whether those are specifically brought out in these specifications and / or the commercial order or not.

**2.00 SERVICECONDITIONS**

The meter to be supplied against this specification shall be suitable for satisfactory continuous operation under the following tropical conditions.

a) Maximum ambient temperature	55°C
b) Maximum ambient temperature in shade	45°C
c) Minimum temperature of air in shade	35°C
d) Maximum daily average temperature	40°C
e) Maximum yearly weighted average temperature	32°C
f) Relative Humidity	10 to 95 %
g) Maximum Annual rainfall	1450 mm
h) Maximum wind pressure	150 kg/m <sup>2</sup>
i) Maximum altitude above mean sea level	1000 meter
j) Isoceraunic level	50 days/year
k) Seismic level (Horizontal acceleration)	0.3 g

---

**TECHNICAL SPECIFICATION OF THREE PHASE 10-60 AMPS PREPAID METER**

---

- 1) Climate: Moderately hot and humid tropical climate conducive to rust and fungus growth.

### **3.00 APPLICABLE STANDARDS**

While drawing these specifications, reference has been made to following Indian and International Standard specification. In case certain details are not covered in these specifications, the relevant Indian and International Standard shall be applicable.

IS: 16444 / 2015 of the latest version including CBIP Tech – report - 325 amended up to date, CEA regulations and MERC guidelines with latest amendments.

IS: 15707 / 2006: Specification for Testing, evaluation, installation & maintenance of AC Electricity Meters-Code of Practice.

IEC 62052-11 (2003) : Electricity Requirements (AC) General Requirements, Tests and Test conditions for A.C. Static Watt hour meter for active energy Class 1.0 and 2.0.

IEC 62053-21 (2003): A.C. Static Watt hour meter for active energy Class 1.and 2.0.

CEA Regulation on installation and operation of meters dtd: 17/03/2006 with all latest amendments

The equipment meeting with the requirements of other authoritative standards, which ensures equal or better quality than the standard mentioned above, also shall be considered.

For conflict related with other parts of the specification, the order of priority shall be – (i) this technical specification, (ii) IS: 16444 / 2015 of the latest version.

NOTE: Unless otherwise specified elsewhere in this specification the meters shall conform to the latest version available of the standard as specified above. If above IS/IEC reports are amended, reference has to be made to Amended IS/IEC/Report up to the date of tenderization.

### **4.00 SYSTEM ARCHITECTURE**

#### **4.01 24x7 Online System**

Prepaid metering system should be 24x7 online system, where prepaid meter should be capable to communicate with prepaid server. Also meter should push billing parameters,tamper information to prepaid server at regular intervals and meter should be capable to connect/disconnect the load according to commands received from prepaid server.

---

**TECHNICAL SPECIFICATION OF THREE PHASE 10-60 AMPS PREPAID METER**

---

The prepaid metering system with communication module shall comprise of following components.

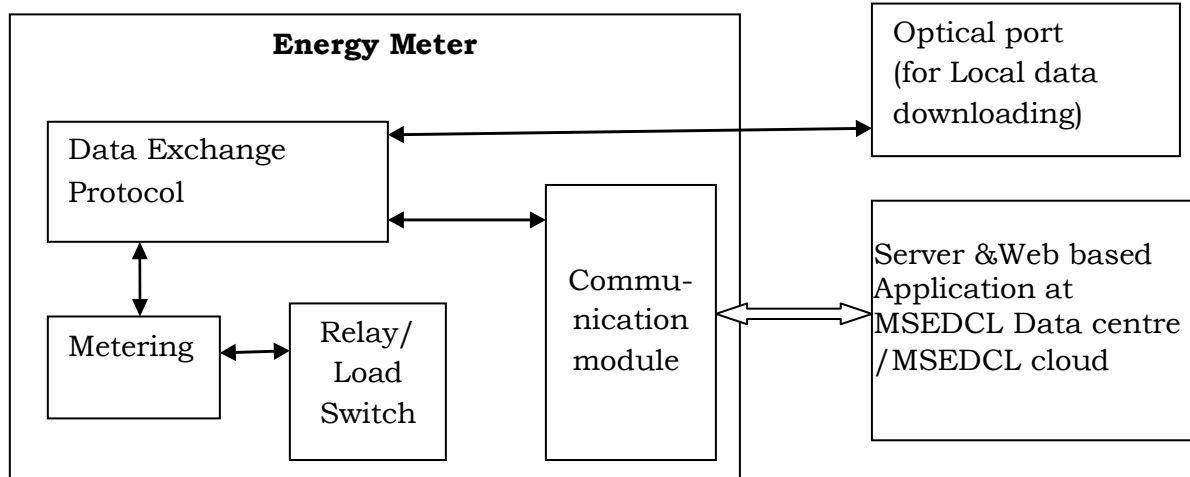

#### 4.02 Metering:

Metering and metrology requirement shall be according to IS 16444:2015 (A.C.Static direct connected watt-hour smart meters Class 1 and 2. - specifications).

#### 4.03 Relay/Load Switch:

The meter shall be provided with switching elements, integral with the meter enclosure, to control the flow of electricity to the load at the instance of connect/disconnect commands as per functional needs of the system.

#### 4.04 Communication module:

The meter shall be provided with in-built/plug-in type GPRS communication module capable of establishing wireless communication with external entities such as Prepaid server, Head End System etc. Two way communication with external entities should be possible.

#### 4.05 Optical port:

The meter should have optical port for wired data download locally. The optical port complying with hardware specifications detailed in IEC – 62056 – 21. The baud rate while downloading data through optical port should be 9600. It should be possible to download the data through optical port in case of power failure.

#### 4.06 Prepaid Engine & Web based prepaid application:

Remote server having prepaid engine and web base prepaid

---

**TECHNICAL SPECIFICATION OF THREE PHASE 10-60 AMPS PREPAID METER**

---

application with all the vending station functionalities will be hosted on remote server at MSEDCL data center/MSEDCL cloud. The bidder is responsible for uptime of remote server.

### 5.00 GENERAL TECHNICAL REQUIREMENTS

The equipment shall conform to the following specific parameters.

5.01 The meter to be supplied shall bear ISI mark before commencement of supply.

#### 5.02 Class of Accuracy:

The class of accuracy of the energy meter shall be 1.0. The accuracy shall not drift with time.

#### 5.03 Current & Voltage Rating:

The current rating shall be 10 - 60 Amps. The rated basic current (I<sub>b</sub>) shall be 10 Amps.

The maximum continuous current (I<sub>max</sub>) shall be 600% of rated basic current i.e. 60 Amps. Moreover the 10 - 60 Amps meter shall work accurately upto 120% of I<sub>max</sub>, i.e. 72 Amps.

The Voltage Rating shall be 240 volts. The voltage range shall be (-) 40 % to (+) 20% of rated voltage, i.e. 144 Volts to 288 Volts.

#### 5.04 Temperature:

The reference temperature for performance shall be 27° C. The mean temperature co-efficient shall not exceed 0.07%. Temperature rise shall be as per IS: 15884 / 2010 of the latest version.

#### 5.05 Power Factor:

Power Factor range: Zero Lag to unity to Zero Lead to unity

Avg. P.F =  $\frac{\text{Total (kWh)}}{\text{Total (kVAh)}}$

Total (kVAh)

$\text{kVAh} = \sqrt{(\text{kWh})^2 + (\text{RkVAhlag} + \text{RkVAhlead})^2}$

#### 5.06 Power Consumption.

##### 5.06.01 Voltage Circuit:

The active & apparent power consumption in voltage circuit including power supply of meter at reference voltage, reference temperature & frequency shall not exceed 5 Watts & 15 VA during the idle mode communication module. The additional power requirement during data transmission shall not exceed 7W per communication module.

**TECHNICAL SPECIFICATION OF THREE PHASE 10-60 AMPS PREPAID METER**

---

**5.06.02 Current Circuit:**

The apparent power taken by current circuit at maximum current, reference frequency & reference temperature shall not exceed 11.5 VA.

**5.07 Starting Current.**

Meter shall start registering the energy at 0.2 % of basic current ( $I_b$ ).

**5.08 Frequency.**

The rated frequency shall be 50 Hz with a tolerance of  $\pm 5\%$ .

**6.00 CONSTRUCTION****6.01 GENERAL MECHANICAL REQUIREMENT**

The prepaid meter shall be designed and constructed in such a way as to avoid introducing any danger in normal use and under normal conditions, so as to ensure especially:

- a) personal safety against electric shock;
- b) personal safety against effects of excessive temperature;
- c) protection against spread of fire;
- d) protection against penetration of solid objects, dust and water in the meter.

6.02 Meters are required for measurement of Active Energy and shall conform to the latest edition of IS: 16444 / 2015(Alternating Current Static direct connected watt-hour smart meters Class 1 and 2 – Specification.

6.03 The meter shall measure the electrical energy consumed.

6.04 All parts, which are subject to corrosion under normal working conditions, shall be protected effectively against corrosion by suitable method to achieve durable results. Any protective coating shall not be liable to damage by ordinary handling nor damage due to exposure to air, under normal working conditions. The electrical connections shall be such as to prevent any opening of the circuit under normal conditions of use as specified in the standard, including any overload conditions specified in the standard. The construction of the meter shall be such as to minimize the risks of short-circuiting of the insulation between live parts and accessible conducting parts due to accidental loosening or unscrewing of the wiring, screws, etc. The meter shall not produce appreciable noise in use.

6.05 The meter shall be projection type, dust and moisture proof. The meter base & cover shall be made out of unbreakable, high grade, fire

---

**TECHNICAL SPECIFICATION OF THREE PHASE 10-60 AMPS PREPAID METER**

---

resistant Polycarbonate material so as to give it tough and non-breakable qualities. The meter base & cover shall be transparent. The meter body shall be type tested for IP51 degree of protection as per IS: 12063 against ingress of dust, moisture & vermin, but without suction in the meter.

### **6.06 METERCASE**

The base and cover shall be ultra-sonically welded (continuous welding) so that once the meter is manufactured and tested at factory, it shall not be possible to open the cover at site except the terminal cover and any non-permanent deformation cannot prevent the satisfactory operation of the meter. The components shall be reliably fastened and secured against loosening. The manufacturer shall put at least one seal on meter body before dispatch. The thickness of material for meter body shall be 2 mm minimum. The holding on and sealing screws shall be held captive in the meter cover. The meter shall have a durable and substantially continuous enclosure made wholly of insulating material, including the terminal cover which envelopes all metal parts.

### **6.07 TERMINALS & TERMINALBLOCK**

- 6.07.01 The terminal block shall be made from high quality non-hygroscopic, fire retardant, reinforced polycarbonate (non-Bakelite) which shall form an extension of the meter case.
- 6.07.02 The material of which the terminal block is made shall be capable of passing the tests given in IS 13360 (Part 6/Sec 17) for a temperature of 135°C and a pressure of 1.8 MPa (Method A). The holes in the insulating material which form an extension of the terminal holes shall be of sufficient size to also accommodate the insulation of the conductors.
- 6.07.03 The conductors where terminated to the terminals shall ensure adequate and durable contact such that there is no risk of loosening or undue heating. Screw connections transmitting contact force and screw fixings which may be loosened and tightened several times during the life of the meter shall screw into a metal nut. All parts of each terminal shall be such that the risk of corrosion resulting from contact with any other metal part is minimized.
- 6.07.04 Electrical connections shall be so designed that contact pressure is not transmitted through insulating material.
- 6.07.05 Two screws shall be provided in each current terminal for effectively clamping the external leads or thimbles. Each clamping screw shall

**TECHNICAL SPECIFICATION OF THREE PHASE 10-60 AMPS PREPAID METER**

engage a minimum of three threads in the terminal. The ends of screws shall be such as not to pierce and cut the conductors used.

- 6.07.06 The minimum internal diameter of terminal hole shall be as per IS.
- 6.07.07 The terminals, the conductor fixing screws or the external or internal conductors shall not be liable to come into contact with terminal covers.
- 6.07.08 The termination arrangement shall be extended type as per as per clause number 4.2.5 of IS: 15884 / 2010 of the latest version irrespective of rear connections.
- 6.07.09 The manufacturer shall ensure that the supporting webs between two terminals of the terminal block shall be sufficiently high to ensure that two neighboring terminals do not get bridged by dust and there shall not be any possibility of flash over between adjacent terminals of the terminal block.
- 6.07.10 The construction of the meter shall be suitable for its purpose in all respects and shall be given reasonable assurance of continuous performance in all mechanical, electrical and magnetic adjustments. The construction shall be such that the meter is not prone to produce audible noise in use. The meter cover & terminal cover shall be of injection molded in transparent UV stabilized polycarbonate in a natural transparent colour.

Polycarbonate material of only following manufacturers shall only be used:

- |                  |   |
|------------------|---|
| a) GEPLASTICS    | LEXAN 943A FOR COVER AND TERMINAL COVER |
|                  | LEXAN 503R FORBASE                      |
| b) BAYER         | GRADE CORRESPONDING TO ABOVE            |
| c) DOW CHEMICALS | -----do -----                           |
| d) MITSUBISHI    | -----do-----                            |
| e) TEJIN         | -----do -----                           |

The meter base shall be manufactured from high quality industrial grade material viz. Polycarbonate with 10 % glass filled which shall meet following properties to ensure higher reliability and long life of the meter case.

- 6.08 A sticker label containing warning notice in Marathi language which is to be stick up on meters front cover or printed on meter name plate with easily readable font size not less than 10 in red colour, which reads as “सावधान ! मीटरला फेरफार करण्याचा प्रयत्न केल्यास अधिकतम वेगाने वीज नोंदणी



होणार. ”

### **6.09 TERMINALCOVER**

- 6.09.01 The termination arrangement shall be provided with an extended transparent terminal cover as per clause number 4.2.5 of IS: 15884 / 2010 of the latest version irrespective of rear connections.
- 6.09.02 The terminal cover of a meter shall be sealable independently of the meter cover to prevent unauthorized tampering.
- 6.09.03 The terminal cover shall enclose the actual terminals, the conductor fixing screws and unless otherwise specified, a suitable length of external conductors and their insulation.
- 6.09.04 The fixing screws used on the terminal cover for fixing and sealing in terminal cover shall be held captive in the terminal cover.
- 6.09.05 When the meter is mounted, no access to the terminals shall be possible without breaking seals(s) of the terminal cover.
- 6.09.06 The terminal cover shall be made out of unbreakable, high grade, fire resistant Polycarbonate material so as to give it tough and non-breakable qualities. The terminal cover shall be transparent.

### **6.10 RATING OF TERMINALS**

The terminals shall be of suitable rating and shall be capable of carrying 120% of  $I_{max}$  (i.e. 72 Amp) and made of electro-plated (or tinned) brass and shall be of replaceable type.

- 6.11 The provision shall be made on the meter for at least two seals to be put by utility user.
- 6.12 All insulating materials used in the construction of the meter shall be substantially non-hygroscopic, non ageing and of tested quality.
- 6.13 A push button shall be provided for high resolution reading of display with three decimal digits as brought out elsewhere in this specification (optional).

### **6.14 RESISTANCE TO HEAT AND FIRE**

The terminal block, the terminal cover, the insulating material retaining the main contacts in position and the meter case shall ensure reasonable safety against the spread of fire. They shall not be ignited by thermal overload of live parts in contact with them.

The material of the terminal block shall not deflect under heating. To comply therewith, they must fulfill the tests as specified in 5.2.4 of IS: 15884 / 2010 of the latest version.

---

**TECHNICAL SPECIFICATION OF THREE PHASE 10-60 AMPS PREPAID METER**

---

A push button shall be provided for scrolling the parameters in Alternate Display (On Demand) mode as well as forced it in emergency credit units in the meter as brought out elsewhere in the specification.

**6.15 REAL TIME INTERNAL CLOCK(RTC)**

The real time quartz clock shall be used in the meter for maintaining time (IST) and calendar. The RTC shall be non - rechargeable and shall be pre-programmed for 30 Years Day / date without any necessity for correction. The maximum drift shall not exceed +/- 300 seconds per year. The calendar and the clock shall be correctly set to Indian Standard Time. The RTC shall have long life (minimum 10 Years) with Non rechargeable battery.

6.16 Meter memory shall have the following details.

- Transaction history data with date & time
- All the events history with time based and category based information,
- Monthly history and consumption data of the energy consumed for the last 12 months,
- All the limiting parameters shall also be available in meter reading.

**6.17 RETENTION TIME OF THE NON-VOLATILE MEMORY**

For long outages, the payment meter shall be designed such that any data necessary for correct operation shall be retained for a minimum period of 10 years without an electrical supply being applied to the meter.

**6.18 OUTPUT DEVICE**

- 6.18.01 The meter shall have a test output device preferably with flashing red LED accessible from front and capable of being monitored with suitable testing equipment.
- 6.18.02 Output devices generally may not produce homogeneous pulse sequences. Therefore, the manufacturer shall state the necessary number of pulses to ensure that measurement uncertainty factor due to repeatability of meter is less than 1/10 of the error limits specified at different test points and consistent with desired resolution.
- 6.18.03 The resolution of the test output in the form of pulses of high resolution register, whether accessible on the meter through external display, shall be sufficient to conduct satisfactorily accuracy test at lowest test point defined in particular requirements in less than 5 min and starting current test in less than 10 min.

---

**TECHNICAL SPECIFICATION OF THREE PHASE 10-60 AMPS PREPAID METER**

---

- 6.19 The meter shall be capable to withstand phase to phase voltage (440V) if applied between phase to neutral continuously.
- 6.20 Power supply unit in the meter shall be transformer less to avoid magnetic influence.
- 6.21 Meter shall be tamper proof. No tampering shall be possible through Optical port.
- 6.22 Display parameters in the meter shall not be accessible for reprogramming at site through any kind of communication.
- 6.23 The measurement by meter shall not get influenced by injection of High frequency AC Voltage / chopped signal / DC signal and harmonics on the terminals of the meter.
- 6.24 The meter shall record and display total energy including Harmonic energy.
- 6.25 The meter shall be provided with LED/LCD indicators for communication in progress. Two separate LED/LCD indicators should be provided for data transmission (TxD) mode and data receiving (RxD) mode.

**6.26 SELF DIAGNOSTIC FEATURES**

- 6.30.01 The meter shall be capable of performing complete self diagnostic check to monitor the circuits for any malfunctioning to ensure integrity of data memory location all the time.
- 6.30.02 The meter shall display unsatisfactory functioning / nonfunctioning / malfunctioning of Real Time Clock, battery.
- 6.30.03 All display segments: "LCD Test" display shall be provided for this purpose.

**6.27 WIRE / CABLE LESS DESIGN**

- The meter shall be wireless to avoid improper soldering & loose connection / contact.
- 6.28 The meter shall remain immune for the test of electromagnetic HF/Rf defined under the test no. 4.0 mentioned in table 20 for EMI/EMC of IS 13779:1999 amended up to date. The meter shall remain immune for any higher signals than the present standards and MSEDCL technical specifications as indicated above.
- 6.29 The communication of energy meters shall not be affected considering the above feature state in the clause 6.28
- 6.30 The watch dog provided shall invariably protect the hanging of microprocessor during such type of tampering devices.

---

**TECHNICAL SPECIFICATION OF THREE PHASE 10-60 AMPS PREPAID METER**

---

- 6.31 The fully tested double layered glass epoxy shall be used. The latest technology such as hybrid microcircuit or application specific integrating circuit (ASIC) shall be used to ensure reliable performance. The mounting of components on the PCB shall be SMT(Surface Mounted Technology) Type. The electronic components used in the meter shall be of high quality from world renowned manufacturers and there shall be no drift in accuracy of the meter for at least up to 5 ½ years.

The meter PCB shall be wireless to avoid improper soldering & loose connection / contact. The PCB material shall be Glass Epoxy, fire resistance grade FR4, with minimum thickness 1.6 mm. It should be framed by A class vendor.

- 6.32 PCB used in meter shall be made by Surface Mounting Technology.
- 6.33 The meter shall be capable of being read through communication module and optical port.

**6.34 LATCHING RELAY (LOADSWITCH)**

- 6.39.01 Meter shall have three latching relays, one for each phase to disconnect the full load.
- 6.39.02 The latching relay shall be bi-stable type latching switch designed and manufactured in accordance with international standard of IEC and DIN EN 61810 part 1 / VDE 0435 part 201 as well as they shall meet the overload and short circuit requirement of IEC, DIN EN 61036 / 61037 & ANSI C12. The Latching relay shall conform to the load switching capabilities as per relevant IS. The latching relay shall be with trip-free design as given in IS.
- 6.39.03 Precautionary measures shall be taken to protect the latching relay from adverse effects resulting from the ingress or vermin into the payment meter.
- 6.39.04 The latching relay shall be designed and rated to make and break at  $V_{ref}$ ,  $I_{max}$  with a linear resistive load and at  $V_{ref}$ ,  $I_b$ , 0.4 inductive power factor for 3,000 operations.
- 6.39.05 Latching relay should connect and disconnect supply according to signal received from remote server having prepaid engine.
- 6.39.06 Once the load is interrupted by disconnect command from prepaid engine, the latching relay shall only be operable to restore the load after a further appropriate connect command received from prepaid engine or through OPTICAL port.
- 6.35 The meter shall be able to disconnect the load in case of exceeding the current limit ( $105\%I_{max}$ ) after 1 minute on stabilizing the current.

### **6.36 COMMUNICATIONCAPABILITY**

The communication capability of the meter shall be based on in built/plug-in type GPRS communication module and optical port complying with hardware specifications detailed in IEC – 62056 – 21

#### **6.41.01 COMMUNICATIONMODULE**

Functionalities of communication module are as below:

1. Establish 24\*7 wireless communication with external entities such as Prepaid Server, Head End System etc. The communication should be bi-directional i.e. from meter to external entity and from external entity to meter.
2. Communication module should support both push and pull features.
3. Communication module should push continuously instantaneous parameters (as per clause No. 15.03) to prepaid engine running on prepaid server located at MSEDCL data centre/MSEDCL cloud. The interval for pushing instantaneous parameters should be configurable.
4. Events should be pushed to prepaid engine by communication module immediately after occurrence and restoration.
5. It is possible to schedule the communication module from prepaid server to fetch any data on demand.
6. Communication module should transfer the connect/disconnect signals received from prepaid server to meter.

6.41.02 The communication between meter and prepaid server should be secure. It should not be possible to alter the contents during communication.

#### **6.41.03 GPRS COMMUNICATION MODULE**

- i. The meter should have 4G communication module. The 4G module should have facility to fall back to 2G and 3G networks, where 4G network is not available.
- ii. The module should support both Data and SMS transmission. It should have GSM, GPRS/EDGE and 4G LTE features.
- iii. There should be provision to insert SIM card externally. The SIM slot should have adequate sealing arrangements.
- iv. SIMs will be provided by the utility. Also the SIM charges will be borne by the utility.
- v. The functionalities of 4G module should be as below.

---

**TECHNICAL SPECIFICATION OF THREE PHASE 10-60 AMPS PREPAID METER**

---

- a. The module should be capable of establishing wireless communication with external entities such as Server, Head End System etc. The communication should be bi-directional i.e. from meter to external entity and from external entity to meter.
- b. The module should support both push and pull features.
- c. The module should push continuously meter data to prepaid engine running on server located at MSEDCL data center/MSEDCL cloud. The interval for pushing meter data should be configurable from Head End System. Default interval for pushing data is 15 minutes and also it should be configurable.
- d. Events should be pushed to prepaid engine by the module immediately after occurrence and restoration.
- e. It should be possible to schedule the module from server to fetch any data on demand.
- f. The module should transfer the connect/disconnect signals received from server to meter.
- g. The module should auto-configure itself, after insertion of SIM card.
- h. The module should support remote firmware upgrade as well as remote configuration from server.
- vi. The meter should have optical port for wired data downloading. The baud rate while downloading data through optical port should be 9600. It should be possible to download the data through optical port in case of power failure. The meter should support connect/disconnect commands through optical port.

The communication between meter and sever should be secure. It should not be possible to alter the contents during communication

### **7.00 Metering Protocol:**

As per IS: 15959 / 2011 (Part-I) and IS:15959/2016 (Part-II) with latest amendments

### **8.00 TOD TIMING**

There shall be provision for at least 6 (Six) TOD time zones for energy and demand. The number and timings of these TOD time Zones shall be programmable. At present the time zones shall be programmed as below.

Zone A (TZ1): 00=00 Hrs. to 06=00 Hrs. and 22=00 Hrs. to 24=00 Hrs

---

**TECHNICAL SPECIFICATION OF THREE PHASE 10-60 AMPS PREPAID METER**

---

Zone B (TZ2): 06=00 Hrs. to 09=00 Hrs. and 12=00 Hrs. to 18=00 Hrs

Zone C (TZ3): 09=00 Hrs. to 12=00Hrs.

Zone D (TZ4): 18=00 Hrs. to 22=00Hrs.

### **9.00 MAXIMUM DEMAND INTEGRATION PERIOD**

The maximum demand integration period shall be set at 30 minute as per requirement.

### **10.0 MD RESET**

It shall be possible to reset MD by the following options:

Auto reset at 24:00 hrs at the end of each billing cycle: Automatic reset at the end of certain predefined period (say, end of the month). This option shall be programmable through prepaid server for the actual date required. No push button shall be provided for MD reset.

### **11.0 WEB BASED PREPAID APPLICATION**

**11.01** The bidder shall develop web based prepaid application which will be deployed on server at MSEDCL data centre/MSEDCL cloud.

**11.02** Web based prepaid application should be developed in any platform such as Java, .Net etc.

**11.03** This application should be scalable and performance of application shall not decrease with increasing number of users.

**11.04** Web based prepaid application should be integrated with MSEDCL New Connection (NC) & legacy billing system. The updation made in prepaid consumer data at NC system and billing system should be reflected immediately into the prepaid application and vice-versa. Following provisions should be done.

- Change in connection type of consumer from prepaid to postpaid and vice-versa. If connection type is changed from postpaid to prepaid, there shall be provision to assign prepaid meter for such consumers.

-Provision for permanent disconnection of prepaid consumer.

**11.05** Web based prepaid application should support following functionalities.

- 1) Login:** There should provision to login into prepaid application. Separate login should be provided for consumer and MSEDCL field offices. Also there should be login with administrator role.
- 2) Configuration of consumers:** After installation of prepaid meters, there should provision to configure the consumer and meter details into the prepaid application. This configuration is to be done through

---

**TECHNICAL SPECIFICATION OF THREE PHASE 10-60 AMPS PREPAID METER**

---

integration with MSEDCL billing system.

- 3) **New consumer registration:** Newly added consumers will be registered on MSEDCL New Connection (NC) system. Prepaid application should fetch data of newly registered consumers from this system and the same shall be updated in the database through web service.
- 4) **Meter assignment/replacement:** If meter of consumer is replaced in the field and/or connection type is changed from postpaid to prepaid, then same shall get updated in prepaid application through integration with MSEDCL New Connection / Meter replacement system.
- 5) **Tariff Change/Consumer category Change:** If tariff of consumer is changed in billing system, same shall get updated in prepaid application through integration with billing system. Also consumer status such as Live, PD, TD etc. as per billing system will be updated in prepaid application through integration with billing system.
- 6) **Recharge Facility:** A consumer should recharge his account through cash/cheque/Net banking/Credit Card/Debit Card/E- wallets/UPI etc. The balance available for that consumer will be updated accordingly after recharge is made. Also the mode of payment i.e. cash/cheque/Net banking/Credit Card/Debit Card/E-wallets/UPI should be captured and updated properly.
- 7) Consumer should be able to view history of recharges made from time to time.
- 8) When the balance remaining will reach to threshold limits, consumer should be notified through SMS.
- 9) Prepaid application should update the energy parameters such as billing, bill history, load survey data and tamper data received from meter into the database along with relevant details. This data should be exported to Text/PDF/Excel format declared by MSEDCL.
- 10) The prepaid application shall create one single file for the uploaded billing data, in ASCII format or XML file as per MIOS for individual meter reading. The billing data format is as follows:
  - i. Reading captured from prepaid meters shall be submitted in one line per meter reading in following format for billing.



**TECHNICAL SPECIFICATION OF THREE PHASE 10-60 AMPS PREPAID METER**

Parameter	Length	Position	Remark
Record Type	4 Char	01-04	PP01/PP03 ( Refer table of Record Types )
Consumer Number	12 chars	05-16	Left Padded with zeros (0)
Make Code	5 chars	17-21	Shall be provided to successful bidder by MSEDCL.
Meter ID(Serial No)	8 chars	22-29	Left Padded with zeros (0)
Current Reading date	8 chars	30-37	DDMMYYYY format
Current kWh reading	8 chars	38-45	Left Padded with zeros (0)
Current KW MD	4 chars	46-49	Left Padded with zeros (0) with decimal part if any
Current KW MD date	8 chars	50-57	DDMMYYYY format
Current KW MD time	4 chars	58-61	HHMI format

ii. Last Line in bill string (Meter Reading) file, will be the check sum logic output asfollows:

- Character 1 to 4 (4 characters): will be (PPT1/PPT3 ). ( Refer table of record types )
- Character 5 to 12 (8 characters): Count of Meter Serial Number, left padding by0.
- Character 13 to 28 (16 characters): Sum of KWh of all above meters. Totallength will be 16, left padding with0.
- Character 29 to 36 (8 characters): Sum of KW MD, total length will be 8, left padding with0.
- Character 37 to 61 (25 characters): Allzeros.

iii. Table of RecordType

Source	Type	Record Type	Prefix Required
Prepaid	Single Phase	Data	<b>PP01</b>
Prepaid	Single Phase	Control Record	<b>PPT1</b>
Prepaid	Three Phase	Data	<b>PP03</b>
Prepaid	Three Phase	Control Record	<b>PPT3</b>

---

**TECHNICAL SPECIFICATION OF THREE PHASE 10-60 AMPS PREPAID METER**

---

**11) TARIFF STRUCTURE:**

The web based prepaid application shall be programmable for tariff structure, tax / rebate, duty, tariff slabs etc, as per the orders given by MERC from time to time. There should be facility to define tariff structure for different tariff categories e.g. residential, commercial, Industrial, temporary-others, temporary-religious etc. Also there should be provision to update tariff structure as per MSEDCL requirements. The tariff structure should include following parameters.

**a) Fixed Charges:**

Prepaid application shall be able to deduct Fixed charges as a whole for the full month as per the applicable Tariff at the beginning of month.

**b) Energy Charges:**

The software shall have capability for defining minimum six tariff slabs. These slabs will be based on number of energy units consumed. It shall be possible to change the slabs. The tariff shall be applicable for the full month as per the tariff category.

**c) Electricity Duty:**

It shall be possible to define electricity duty percentage through prepaid application which will be levied on recharge amount. The electricity duty rate will depend upon applicable tariff category.

**d) Taxes:**

There shall be provision to define various taxes in online prepaid application which has to be levied on recharge amount. E.g. Tax on sale of electricity (To SE), if applicable.

**e) Fuel Cost:**

The software shall have provision to define fuel cost charges for different tariff categories. These charges will deducted from balance of consumer as per units consumed.

**f) Wheeling Charges:**

There shall be provision to define wheeling charges for different tariff categories. These charges will deducted from balance of consumer as per units consumed.

**g) Online Payment Discount:**

The software shall have facility to define online payment discount percentage on recharge amount. Accordingly the discount amount shall be calculated on recharge amount, if paid online.

**h) Rebate:**

The software shall have facility to define rebate percentage on recharge amount. Accordingly the rebate shall be given on recharge amount.

---

**TECHNICAL SPECIFICATION OF THREE PHASE 10-60 AMPS PREPAID METER**

---

**i) Debt Management:**

It shall be possible to collect the Debt from the consumers with the use of the online vending system. The Debt percentage shall be defined in the vending system.

**12) EMERGENCY CREDIT:**

Prepaid application shall be capable to configure for Emergency credit limit so that some defined amount could be provided to consumer after zero balance. The amount of emergency credit will be decided by MSEDCL. When the balance of consumer reaches to zero, meter should not disconnect the power supply and consumer can avail electricity until emergency credit is consumed. The amount of emergency credit should be deducted from the next recharge amount and remaining amount should be updated against the balance.

**13) HAPPY HOURS:**

Prepaid application shall be programmable for happy hours and command to disconnect power supply shall not be sent by prepaid engine during happy hours, even if balance of consumer is reduced to zero. The happy hours are 17:30 to 11:00 on week days. On Sunday and fixed holidays, the happy hours are entire 24 hours. The power supply should be disconnected after end of such happy hours. When consumer account is recharged with new credit, it shall adjust the debited amount first and remaining amount will be updated against the credit balance

**14)** Prepaid application should generate all required reports as per MSEDCL requirements. The reports should be exported in text/excel and PDF formats.

**15)** In case of meters are not communicating with server, exception report should be generated by prepaid application showing list of prepaid meters not online. Also the concerned MSEDCL officer should be notified through SMS if there is communication failure between meter and server continuously for one day.

**16)** It is also possible to schedule the meters for downloading of billing, bill history, tamper and load survey data on demand through this application.

**17) Data upload:** In case meters are not communicating with server, meter data such as energy parameters, tamper data, load survey data will be downloaded through optical port and there shall be provision to upload the same. The energy parameters uploaded will be passed to prepaid engine to update the balance of consumer.

**18) Dash boards:** The information available in the database should

---

**TECHNICAL SPECIFICATION OF THREE PHASE 10-60 AMPS PREPAID METER**

---

be displayed in the form of dash board as per MSEDCL requirements.

**19) Monitoring and control:** MSEDCL users should be able to monitor and control the prepaid metering solution.

**20) Integration with MSEDCL systems:** Prepaid application should be integrated with MSEDCL billing system, MSEDCL New Connection (NC) system & MSEDCL MDAS through web services. Details of new consumers registered, meter replacement, tariff change etc. should be updated in prepaid application from MSEDCL New Connection (NC) system & Billing system through web services. Meter data such as billing data, instantaneous data, bill history, event information & load survey data available in prepaid application should be integrated with MSEDCL MDAS through web services.

**21) Mobile App:** Prepaid application functionality should also be provided through mobile application working on android and iOS. Prepaid functionalities such as prepaid recharge, view existing balance, daily usage etc. should be incorporated in MSEDCL Consumer mobile application. Consumer should be able to view information related to consumption, recharges done, instantaneous balance available etc. through mobile application. Also alerts, notifications or messages should be given to consumer through mobile application.

MSEDCL may suggest changes in above functionalities, reports in prepaid application/mobile app. Also MSEDCL may introduce new functionalities. The bidder shall modify the prepaid application/mobile app as per the MSEDCL requirements.

The bidder shall hand over the source code of web based prepaid application to MSEDCL along with necessary credentials, documentation and training.

## **12.00 PREPAID ENGINE**

12.01 The bidder shall develop prepaid engine which will be installed on central server at MSEDCL data centre/MSEDCL cloud. This engine should be multi threaded application which is continuously communicating with prepaid meters and working in synchronization with prepaid application. Prepaid engine should replicate the accounting process done at meter end to server. Functionalities of prepaid engine should be as follows:

12.02 **Deduction from balance:** Based on the meter data received from meter, prepaid engine should calculate the amount for energy

---

**TECHNICAL SPECIFICATION OF THREE PHASE 10-60 AMPS PREPAID METER**

---

consumed for that interval as per the applicable tariff and this amount should be deducted from the available balance of the consumer.

- 12.03 When the balance reaches to zero, the command should be sent to meter to disconnect the supply. If consumer recharges his account then command to reconnect supply should be sent by the system. Also it should be possible to connect/disconnect the supply of consumer on demand.
- 12.04 Billing, bill history, Tamper and load survey data received from the meter should be passed over to prepaid application.
- 12.05 MSEDCL may suggest changes in above functionalities. The bidder shall be agree to modify the prepaid engine functionalities as per MSEDCL requirements.
- 12.06 The bidder shall hand over the source code of prepaid engine to MSEDCL along with necessary credentials documentation and training.

### **13.00 PREPAID AND CONNECT/DISCONNECTFEATURES**

#### **13.01 Disconnection Mechanism:**

Meter should support disconnection under following conditions:

- a. Over current
- b. Load Control Limit ( Programmable and set by MSEDCL)
- c. Pre-programmed event conditions
- d. Disconnection signal from Prepaid Engine (Remote disconnection on demand) or from optical port.
- e. In case of balance of consumer reduced to zero

#### **13.02 Reconnection Mechanism:**

Meter should support reconnection under following conditions:

- a. Local reconnection due to disconnection under over current & load control limit.
- b. Remote reconnection, after receipt of command from prepaid engine, when consumer recharges account.
- c. Reconnection after receipt of command through optical port.

### **14.00 TAMPER & FRAUD MONITORINGFEATURES:**

#### **14.01 ANTI TAMPERFEATURES**

The meter shall detect and correctly register energy only in forward direction under following tamper conditions:

---

**TECHNICAL SPECIFICATION OF THREE PHASE 10-60 AMPS PREPAID METER**

---

- (i) Change of phase sequence: The meter accuracy shall not be affected by change of phase sequence. It shall maintain the desired accuracy in case of reversal of phase sequence.
- (ii) Reversal of line and load terminals: Even on interchanging the load and line wires, the meter shall register correct energy passing through the meter.
- (iii) Drawing of current through local Earth: the meter shall register accurate energy even if load is drawn partially or fully through a local earth.
- (iv) The three-phase meter shall continue to work even without neutral.
- (v) The three-phase meter shall work in absence of any two phases, i.e. it shall work on any one phase wire and neutral, to record relevant energy.
- (vi) The meter shall work without earth.
- (vii) The potential link shall not be provided.
- (viii) Visual indication shall be provided to safeguard against wrong connections to the meter terminals.
- (ix) The meter shall be immune to the external magnetic field (AC / DC / Permanent) upto 0.2 Tesla. If the accuracy of the meter gets affected under the influence of magnetic field more than 0.2 Tesla, then the same shall be recorded as magnetic tamper event with date & time stamping and the meter shall record energy considering the maximum value current ( $I_{max}$ ) at ref. voltage and unity PF in all the three phases.
- (x) The meter shall be immune to abnormal voltage / frequency generating devices.
- (xi) The meter shall remain immune for the test of electromagnetic HF/RF defined under the test no. 4.0 mentioned in table 20 for EMI/EMC of IS 13779:1999 amended up to date.

**14.02 TAMPER EVENTS**

The meter shall work satisfactorily under presence of various influencing conditions like External Magnetic Field, Electromagnetic Field, Radio Frequency Interference, Harmonic Distortion, Voltage / Frequency Fluctuations and Electromagnetic High Frequency Fields, etc. as per relevant IS.

The no. of times the tampering has been done shall also be registered

---

**TECHNICAL SPECIFICATION OF THREE PHASE 10-60 AMPS PREPAID METER**

---

in the meter.

Minimum 280 numbers of events (occurrences & restoration with date & time) shall be available in the meter memory. The recording of abnormal events shall be on FIFO basis.

All the information of data shall be made available in simple & easy to understand format.

The meter shall have features to detect the occurrence and restoration of the following abnormal events:

**(a) Missing potential and potential imbalance**

The meter shall be capable of detecting and recording occurrence and restoration with date and time the cases of potential failure and low potential, which could happen due to disconnection of potential leads (one or two). Meter shall also detect and log cases of voltage unbalance (10% or more for 5 Minutes.) Higher of the 3 phase voltages shall be considered as reference for this purpose.

**(b) Current unbalance**

The meter shall be capable of detecting and recording occurrence and restoration with date and time of current unbalance (30% or more for 15 minutes).

Higher of the 3 phase currents shall be considered as reference for this purpose.

**(c) Current Reversal**

The meter shall be capable of detecting and recording occurrence and restoration with date and time of reversal of current with phase identification for persistence time of 5minutes.

**(d) Current circuit short**

The meter shall be capable of detecting and recording occurrences and restoration of shorting of any one or two phases of current, with date & time of occurrence and restoration.

**(e) High Neutral Current (CT bypass)**

The meter shall be capable of recording incidences of excess neutral current (if it is in excess 10% of  $I_b$  for more than 5 minutes.).

The meter shall record the total duration of the above abnormalities, time and date of their occurrences and restorations with snapshot of instantaneous electrical conditions viz. System Voltages, Phase Currents & System PF.

**TECHNICAL SPECIFICATION OF THREE PHASE 10-60 AMPS PREPAID METER**
**(f) Power ON /OFF**

The meter shall be capable to record power ON/OFF events in the meter memory. All potential failure shall record as power off event.

**(g) Meter Cover Open**

In the event the meter is forcibly opened, even by 2 to 4 mm variation of the meter cover, same shall be recorded as tamper event with date & time stamping and the meter shall continuously display that the cover has been tampered. It is suggested that the manufacturer shall develop their software such that there will be some time delay for activation of this tamper feature and during that period only the meter cover shall be fitted. The delay in activation of software shall be for one instance only. After the meter cover is fitted, it shall get activated immediately without any delay.

(h) Tamper indications to be displayed on LCD display to be defined by suppliers.

(i) The threshold values for various tamper are as below.

Sr. No.	Description	Occurrence (With Occ. Time 5 min.)	Restoration (With Rest. Time 5 min.)
1.	PT link Missing (Missing potential)	< 50% of Vref	> 50% of Vref
2.	Over voltage in any phase	> 115 % of Vref	< 115 % of Vref
3.	Low voltage in any phase	< 70 % of Vref	> 70 % of Vref
4.	Voltage Unbalance (Diff. of phase voltages)	> 10 % Vref	< 10 % Vref
5.	CT reverse	Change direction in of current	Current flow in forward direction



**TECHNICAL SPECIFICATION OF THREE PHASE 10-60 AMPS PREPAID METER**

6.	CT Open	Zero Amps in one or two phases and current in at least 1 phase is >5% Ib for 15 minutes	>3 % Ib for 15 min in the tampered phase for 15 min
7.	Current Unbalance (Diff. of phase currents)	> 30 % Ib for 15 min	< 30 % Ib for 15 min
8.	Current Bypass	Bypass Current >10 % Ib for 15 min	Bypass Current <10%Ib for 15 min
9.	Over Current in any Phase	> 105 % I <sub>max</sub>	< 105 % I <sub>max</sub>
10.	Influence of permanent magnet or AC /DC electromagnet / permanent magnet	Immediate	1 minute after removal
11.	Neutral Disturbance	--	--
12.	Power failure	Immediate	
13.	Very Low PF	--	--
14.	Meter Cover Opening	2 to 4 mm	--

For above abnormal conditions, the recording of events shall be on FIFO basis.

Event data should be immediately pushed by the meter to prepaid server on occurrences and restorations of events. Also it shall be possible to retrieve the abnormal event data along with all related snap shots data through optical port and upload the same to web based prepaid application.

**15.00 DISPLAY OF MEASURED VALUES**

15.01 The display shall be permanently backlit LCD, visible from the front of the meter. The display shall be electronic and when the meter is not energized, the electronic display need not be visible.

---

**TECHNICAL SPECIFICATION OF THREE PHASE 10-60 AMPS PREPAID METER**

---

**15.02 MINIMUM CHARACTERSIZE:**

The energy display shall be minimum 5 digits. The height of the display characters for the principal parameters values shall not be less than 5 mm. The size of digit shall be minimum 10 x5mm.

15.03 The principal unit for the measured values shall be the kilowatt hour (kWh & kVAh) and the maximum demand in kVA (kVA MD) alongwith the time.

15.04 The decimal units shall not be displayed for cumulative kWh & kVAh in auto scroll mode. However it shall be displayed in push button mode for high resolution display for testing.

15.05 The meter shall be pre-programmed for following details.

Voltage: 240V

Integration period for kVA MD shall be of 30 minutes real time based.

The meter shall auto reset kVA maximum demand (KVA MD) at 2400 Hrs. of last day of each calendar month and this value shall be stored in the memory along with the cumulative kWh & kVAh reading. No reset push button shall be provided.

The Default Display (Auto scrolling mode) shall switch to Alternate Display (On Demand Display Mode) after pressing the push button continuously for 5 seconds.

The Alternate Display (On Demand Display Mode) shall switch over to Default Display if the push button is not operated for 15 seconds.

15.06 The meter shall have facilities to measure, record and display the parameters as per IS: 16444 / 2015 of the latest version.

Where multiple values are presented by a single display, all relevant values shall be available via appropriate selection (choice of selection shall be general, for example push button).

15.07 The register shall be able to record and display starting from zero, for a minimum of 1500 h, the energy corresponding to maximum current at reference voltage and unity power factor. The register shall not rollover during this duration.

**15.08 DISPLAY INDICATORS:**

The following shall be displayed permanently by LED / LCD as a minimum and shall be visible from the front of the prepaid meter.

- a. Supply indication.
- b. Relay status.
- c. Earth load indication (if condition occurred).

**TECHNICAL SPECIFICATION OF THREE PHASE 10-60 AMPS PREPAID METER**

d. Meter cover forcibly open tamper event

The meter shall be provided with LEDs to indicate communication in progress. Two separate LED indicators should be provided for data transmission (TxD) mode and data receiving (RxD) mode.

15.09 The display parameters shall be preprogrammed at factory.

15.10 **MINIMUM DISPLAY CAPABILITY (MEASURINGPARAMETERS):**

Display other than specified below shall be blocked.

The scroll period for auto scroll shall be 10 sec.

(A)	Default Display
1.	LCD Test
2.	Meter Sr. No.
3.	Real Time Clock – Date & Time
4.	Cumulative Energy – kWh
5.	Cumulative Energy – kWh - TOD Zone A (TZ1)
6.	Cumulative Energy – kWh - TOD Zone B (TZ2)
7.	Cumulative Energy – kWh - TOD Zone C (TZ3)
8.	Cumulative Energy – kWh - TOD Zone D (TZ4)
9.	Cumulative Energy – kVARh– Lag
10.	Cumulative Energy – kVARh - Lag- TOD Zone A (TZ1)
11.	Cumulative Energy – kVARh - Lag- TOD Zone B (TZ2)
12.	Cumulative Energy – kVARh - Lag- TOD Zone C (TZ3)
13.	Cumulative Energy – kVARh - Lag- TOD Zone D (TZ4)
14.	Cumulative Energy –kVARh– Lead
15.	Cumulative Energy – kVARh - Lead- TOD Zone A (TZ1)
16.	Cumulative Energy – kVARh - Lead- TOD Zone B (TZ2)
17.	Cumulative Energy – kVARh - Lead- TOD Zone C (TZ3)
18.	Cumulative Energy – kVARh - Lead- TOD Zone D (TZ4)

**TECHNICAL SPECIFICATION OF THREE PHASE 10-60 AMPS PREPAID METER**

19.	Cumulative Energy – kVAh
20.	Cumulative Energy – kVAh - TOD Zone A (TZ1)
21.	Cumulative Energy – kVAh - TOD Zone B (TZ2)
22.	Cumulative Energy – kVAh - TOD Zone C (TZ3)
23.	Cumulative Energy – kVAh – TOD Zone D (TZ4)
24.	Current MD – kVA with occurrence date & time
25.	MD - kVA – TOD Zone A (TZ1) with occurrence date & time
26.	MD - kVA – TOD Zone B (TZ2) with occurrence date & time
27.	MD - kVA – TOD Zone C (TZ3) with occurrence date & time
28.	MD - kVA – TOD Zone D (TZ4) with occurrence date & time
29.	Number of MD – kVA reset
30.	Rising MD with elapsed time
31.	Three Phase Power Factor – PF
32.	Cumulative Tamper Count
33.	Meter Cover Opening –Occurance with date and time.
<b>(B)</b>	<b>On – Demand Display (Alternate Display)</b>
1.	Meter Sr. No.
2.	Last date & time of MD - kVA reset
3.	Current – $I_R$
4.	Current – $I_Y$
5.	Current – $I_B$
6.	Voltage – $V_R$
7.	Voltage – $V_Y$
8.	Voltage – $V_B$
9.	Signed Power Factor – R Phase

**TECHNICAL SPECIFICATION OF THREE PHASE 10-60 AMPS PREPAID METER**

10.	Signed Power Factor – Y Phase
11.	Signed Power Factor – B Phase
12.	Frequency
13.	High resolution kWh (for calibration)
14.	High resolution kVAh Lag(for calibration)
15.	High resolution kVAh Lead(for calibration)
16.	High resolution kVAh (for calibration)
17.	Rising MD with elapsed time (for calibration/testing)
18.	M1 MD - kVA – TOD Zone A (TZ1) with occurrence date & time
19.	M1 MD - kVA –TOD Zone B (TZ2) with occurrence date & time
20.	M1 MD - kVA – TOD Zone C (TZ3) with occurrence date & time
21.	M1 MD - kVA – TOD Zone D (TZ4) with occurrence date & time
22.	M2 MD - kVA – TOD Zone A (TZ1) with occurrence date & time
23.	M2 MD - kVA –TOD Zone B (TZ2) with occurrence date & time
24.	M2 MD - kVA – TOD Zone C (TZ3) with occurrence date & time
25.	M2 MD - kVA – TOD Zone D (TZ4) with occurrence date & time
26.	Last Tamper Event with date and time.

**Note:**

- (1) Other kVA MD values shall be available in reset backup data for 12 months.
- (2) The meter display shall return to Default Display Mode if the “On Demand Push Button” is not operated for 15sec.
- (3) The meter shall display the tamper meter cover open with date & time in auto scroll mode along with other parameters

**16.00 BILLING DATA, BILLING HISTORY, LOAD SURVEY & TAMPER DATA**
**16.01 BILLING DATA**

The billing data is summarized as below.

**TECHNICAL SPECIFICATION OF THREE PHASE 10-60 AMPS PREPAID METER**

<b>Sr. No.</b>	<b>Parameters</b>
1.0	Billing Date
2.0	System Power Factor for billing period
3.0	Cumulative Energy – kWh
4.0	Cumulative Energy – kWh for TZ1
5.0	Cumulative Energy – kWh for TZ2
6.0	Cumulative Energy – kWh for TZ3
7.0	Cumulative Energy – kWh for TZ4
8.0	Cumulative Energy – kVAh
9.0	Cumulative Energy – kVAh for TZ1
10.0	Cumulative Energy – kVAh for TZ2
11.0	Cumulative Energy – kVAh for TZ3
12.0	Cumulative Energy – kVAh for TZ4
13.0	Maximum demand (kVA MD) with date & time.
14.0	Maximum demand (kVA MD) with date & time for TZ1.
15.0	Maximum demand (kVA MD) with date & time for TZ2.
16.0	Maximum demand (kVA MD) with date & time for TZ3.
17.0	Maximum demand (kVA MD) with date & time for TZ4.
18.0	Billing power ON duration in Minutes (During billing period)

**16.02 BILLINGHISTORY:**

The meter shall have sufficient non-volatile memory for recording history of billing parameters (as per above table) for last 12 months.

**16.03 INSTANTANEOUSPARAMETERS:**

Instantaneous parameters are summarized as below.

**TECHNICAL SPECIFICATION OF THREE PHASE 10-60 AMPS PREPAID METER**

<b>Sr. No.</b>	<b>Parameters</b>
1.0	Real Time Clock- Date & Time
2.0	Current, $I_R$
3.0	Current, $I_Y$
4.0	Current, $I_B$
5.0	Voltage, $V_{RN}$
6.0	Voltage, $V_{YN}$
7.0	Voltage, $V_{BN}$
8.0	Three Phase Power Factor, PF
9.0	Number of Power Failures
10.0	Cumulative Power OFF Duration in Minutes
11.0	Cumulative Tamper Count
12.0	Cumulative billing count
13.0	Cumulative Energy – kWh
14.0	Cumulative Energy-kVAh
15.0	Maximum demand (kVAMD)
16.0	Load Limit Function Status
17.0	Load Limit Value in kW
18.0	Relay (Load Switch) Status

For parameter No. 16& 18 the value will be 1 if relay (load switch) is connected and 0 if disconnected

**16.04 LOAD SURVEY PARAMETERS:**

The array of data to be retained inside the meter memory shall be for the 60(Power On) days for a capture period of 30 minutes. The load survey data shall be first in first out basis (FIFO). Load survey data shall be logged on non-time based basis, i.e. if there is no power for

---

**TECHNICAL SPECIFICATION OF THREE PHASE 10-60 AMPS PREPAID METER**

---

more than 24 hours, the day shall not be recorded. Whenever meter is taken out and brought to laboratory, the load survey data shall be retained for the period of actual use of meter. The load survey data can be retrieved as and when desired and load profiles shall be viewed graphically / analytically with the help of meter application software. The meter application software shall be capable of exporting / transmitting these data for analysis to other user software in spreadsheet format.

The load survey parameters are as below.

(1)	Real Time Clock – Date and Time
(2)	Current – $I_R$
(3)	Current – $I_Y$
(4)	Current – $I_B$
(5)	Voltage – $V_{RN}$
(6)	Voltage – $V_{YN}$
(7)	Voltage – $V_{BN}$
(8)	Block Energy – kWh
(9)	Block Energy – kVArh – lag
(10)	Block Energy – kVArh – lead
(11)	Block Energy – kVAh

### 16.05 TAMPERDATA:

Event data (as per clause No. 14) should be immediately pushed by the meter to prepaid server on occurrences and restorations of events. Also it shall be possible to retrieve the abnormal event data along with all related snap shots data through OPTICAL port and upload the same to web based prepaid application.

### 17.00 DEMONSTRATION

The purchaser reserves the right to ask for the demonstration of the equipment offered at the purchaser's place.



## **18.00 CONNECTION DIAGRAM AND TERMINAL MARKINGS**

The connection diagram of the meter shall be clearly shown on inside portion of the terminal cover and shall be of permanent nature. Meter terminals shall also be marked and this marking shall appear in the above diagram. The diagram & terminal marking on sticker will not be allowed.

## **19.00 Deleted**

## **20.00 MARKING OF METER**

### **20.01 NAMEPLATE**

Meter shall have a name plate clearly visible, effectively secured against removal and indelibly and distinctly marked with all essential particulars as per relevant standard. The manufacturer's meter constant shall be marked on the Name Plate.

In addition to the requirement as per IS, following shall be marked on the Name Plate.

Purchase Order No.

Month and Year of manufacture

Name of purchaser i.e. MSEDCL

Guarantee Five Years

ISI mark

Communication Technology with Carrier frequency

The meter Serial No. shall be Bar Coded along with Numeric No. The size of Bar Code shall not be less than 35x5 mm. Stickers for meter serial no., in any case will not be accepted.

A sticker label containing warning notice in Marathi language which is to be stick up on meters front cover or printed on meter name plate with easily readable font size not less than 10 in red colour, which reads as

“सावधान ! मीटरला फेरफार करण्याचा प्रयत्न केल्यास अधिकतम वेगाने वीज नोंदणी होणार.”

## **21.00 TESTS**

### **21.01 TYPE TESTS**

The prepaid meter to be supplied shall be fully type tested for the properties / requirement as per IS: 16444/2015, IS 15884 / 2010 and all relevant IS and IEC of the latest version and external AC / DC magnetic influence tests as per CBIP Tech-Report 325 with latest amendments. Type test certificate shall be submitted before commencement of supply and the same shall not be more than 5

---

**TECHNICAL SPECIFICATION OF THREE PHASE 10-60 AMPS PREPAID METER**

---

years old at the time of commencement of supply. The Type Test Reports shall clearly indicate the constructional features of the type tested meter.

The Type Test Certificate as per IS: 16444 / 2015 (For the purpose of IS 16444/2015 all definitions given in IS 16444 shall apply) shall be submitted along with the offer. Separate Type Test Reports for each type of meter to be supplied shall be submitted. All the Type Tests shall have been carried out from Laboratories which are accredited by the National Accreditation Board for Testing and Calibration Laboratories (NABL) of Govt. of India such as CPRI, Bangalore / Bhopal, ERDA Vadodara, ERTL to prove that the meter to be supplied meets the requirements of the specification. Type Test Reports conducted in manufacturers own laboratory and certified by testing institute shall not be acceptable. Type Test for prepaid features as per IS shall be confirmed for the parameters indicated elsewhere in the specification also at manufacturers' lab during inspection.

**All The type test reports including additional acceptance tests of meter to be supplied shall be got approved from Chief Engineer, Testing & Quality Control before commencement of supply.**

The purchaser reserves the right to demand repetition of some or all the type tests in presence of purchaser's representative at purchaser's cost.

- 21.02 Meters to be supplied shall pass all the acceptance and routine test as laid down in IS: 15884 / 2010 of the latest version and also additional acceptance tests as prescribed in this specification. (3 to 8 meter from a lot more than 1,000 shall be sealed randomly in the factory and will be tested for tamper events.)

**21.03 ADDITIONAL ACCEPTANCE TESTS:**

The following additional tests on meter to be supplied shall be carried out in addition to the acceptance tests specified in IS: 15884 / 2010 of the latest version.

**(a) ACCEPTANCE TEST FOR PREPAID FEATURES:**

- i) Test of credit balance & debit.
- ii) Test of friendly credit hours, Start & end time thereof
- iii) Test of disconnect the output supply when credit reach to zero.
- iv) Test of reconnect the output supply on providing credit limit.
- v) Test of disconnect output supply if load / current exceeded the preset value in the meter.

---

**TECHNICAL SPECIFICATION OF THREE PHASE 10-60 AMPS PREPAID METER**

---

- vi) Test of reconnect output supply if load / current falls below the preset value in the meter.
- vii) Test of application of tariff.

**(b) OTHER ACCEPTANCE TESTS:**

- i) Glow wire testing for polycarbonate material.
- ii) The meter shall withstand continuously for a period of at least 5 minutes at a voltage of 440V between phase and neutral without damage/problems,
- iii) Tamper conditions as stated in this specification,
- iv) Power consumption tests,
- v) The meter to be supplied shall comply all the tests for external AC / DC (0.2 T AC magnet) magnetic field as per CBIP Tech Report 88 with latest amendments. Moreover, the magnetic influence test for permanent magnet of 0.5 T for minimum period of 15 minutes shall be carried out, by putting the magnet on the meter body. If the accuracy of the meter gets affected during the test, then the same shall be recorded as magnetic tamper event with date & time stamping and the meter shall record energy considering  $I_{max}$  and reference voltage at unity power factor. After removal of magnet, meter shall be subjected to accuracy test as per IS: 15884 / 2010 of the latest version. No deviation in error is allowed in the accuracy as per specifications.
- vi) The meter shall withstand impulse voltage at 6kV.
- vii) The meter shall remain immune for the test of electromagnetic HF/RF defined under the test no. 4.0 for EMI/EMC of IS 13779:1999 amended up to date. For any higher signals than the present standards and MSEDCL technical specifications indicated above.

The test as per clause no. 26.03 (c) (i) to (iv) shall be carried out at factory for each inspected lot at the time of pre-dispatch inspection.

The tests as per clause no. 26.03 (c) (v) ,(vi)& (vii) shall be carried out on one sample from first lot as per procedure laid down in IS: 15884 / 2010 of the latest version and CBIP Tech. Report - 88 in NABL LAB. The test report shall be got approved from Chief Engineer, Testing & Control Cell before commencement of supply.

**21.04 LIMITS OF ERROR:**

Limits of variation in percentage error due to change in voltage shall not exceed the values given in the following table

---

**TECHNICAL SPECIFICATION OF THREE PHASE 10-60 AMPS PREPAID METER**

---

Sr. No.	Influence quantities	current Value	Power factor	Limits of variation in % error for class 1 meters
a)	Voltage variation - 15% to +10%	I <sub>b</sub>	1	0.7
		I <sub>b</sub>	0.5 lag	1.0
b)	Voltagevariation - 40% & +20%	I <sub>b</sub>	1	1.1
		I <sub>b</sub>	0.5 lag	1.5

- (i) The meter shall be tested at (-) 15% and at (-) 40% of reference voltage as well as (+) 10% and (+) 20% of reference voltage and shall record energy within limits of variation indicated above. However the meter shall continue to register energy up to 50% of the rated voltage.
- (ii) For other influence quantities like frequency variation the limits of variation in percentage error will be as per IS: 15884 / 2010 of the latest version.

## 22.00 GUARANTEED TECHNICAL PARTICULARS

The tenderer shall also furnish the particulars giving specific required details of Meter in schedule `A` attached. The offers without the details in Schedule `A` stands rejected.

## 23.00 TENDER SAMPLE

Tenderer are required to submit 11 (Eleven) nos. of sample meters as per IS: 16444 / 2015 (amended upto date) with communication module as per technical specification with valid type test certificates as per IS: 16444 / 2015 (amended upto date), CBIP tech report 88 (amended upto date) from any of the NABL accredited Lab & valid BIS certificate, connecting telephonic cable with connectors fixed to cable, API / Exe file with documentation and web based prepaid application prepaid engine, documentation, Exe / API for validating downloaded meter data, etc. of each offered type / item along with their offer to EE (SM) in the office of the Chief Engineer, MSEDCL, Material Management Cell, 1<sup>st</sup>Floor, Prakashgad, Bandra (E), Mumbai - 400 051 on or before the time & date stipulated for submission of offer for testing the sample meters in third party NABL Lab like CPRI, ERDA, ERTL, etc. and testing the offered API with BCS and vending software & documentation etc. by our IT Department as per technical specifications for testing of data downloading and prepaid features etc. The type tests carried out as per IS: 16444 / 2015(amended update) during last five years from the date of opening of the tender shall be

---

**TECHNICAL SPECIFICATION OF THREE PHASE 10-60 AMPS PREPAID METER**

---

valid. The offer of those eligible bidders shall only be considered if the meter sample passes the tests at NABL Lab & MSEDCL IT Section. The results of NABL Lab & MSEDCL IT Section shall not be disputed and shall be binding on the bidder.

The required information such as Manufacturer's Name or Trade Name, Sr. No., ISI Certification No. etc. shall be on stickers to be affixed on outer portion of sample meters being submitted along with the offer. Such information shall not be embossed or printed on any part of the sample meter.

Out of these, two samples shall be without Ultrasonic welding to confirm constructional features.

#### **24.00 PRE DESPATCH INSPECTIONS**

All acceptance tests and inspection shall be carried out at the place of manufacturer unless otherwise specially agreed upon by the manufacturer and purchaser at the time of purchase. The manufacturer shall offer to the inspector representing the purchaser, all the reasonable facilities, free of charge, for inspection and testing, to satisfy him that the material is being supplied in accordance with this specification.

The Company's representative / Engineers attending the above testing shall carry out testing on suitable number of meters as per sampling procedure laid down in IS: 15884 / 2010 of the latest version and additional acceptance test as per this specification and issue a test certificate approval to the manufacturer and give clearance for dispatch. All the meters offered for inspection shall be in sealed condition. The seals of sample meter taken for testing & inspection shall be break open & resealed after inspection. The routine tests of latching relay shall also be carried out & confirmed. The first lot of meter may be jointly inspected by the Executive Engineer, Testing Division and the Executive Engineer, Inspection Wing.

#### **25.00 INSPECTION AFTER RECEIPT AT STORES (RANDOM SAMPLE TESTING)**

For carrying out "Random Sample Testing (RST), the sample meter will be drawn from any one of the stores against inspected lot and same shall be tested at respective Testing and Quality Assurance units at Aurangabad, Bhandup, Kolhapur, Nagpur, Nashik & Pune. Sample meter shall be drawn as per Appendix "H" of IS: 13779 / 1999 (amended up to date). Sample meter will be tested by MSEDCL Testing

---

**TECHNICAL SPECIFICATION OF THREE PHASE 10-60 AMPS PREPAID METER**

---

Engineer in presence of supplier's representative jointly for (i) starting current, (ii) Limits of error, (iii) Repeatability of error, (iv) No Load Test as per IS: 15884 / 2010 of the latest version(v) Test for prepaid feature as per clause no. 26.03 (a). The RST shall be carried out by the Testing Division allotted by Chief Engineer, MMCell.

The 5 days advance intimation shall be given to the supplier and if the supplier fails to attend the joint inspection on the date informed, the testing will be carried out by our testing engineer in absence of supplier's representative. If the meter fails in above random sample testing, the lot will be rejected.

**26.00 TRAINING**

The bidder / manufacturer shall arrange various training programmes for administration training, user training and trouble shoot training free of cost with supported documents like system software manual, system operation manual. Training shall be imparted to at least 100 officers for user training and at least 5 officers for administration training.

**27.00 GUARANTEE**

The prepaid meters with communication module and allied software / hardware shall be guaranteed for the period of five years from the date of successful commissioning certificate from the concerned Circle Office of MSEDCL or five and half years from the date of dispatch whichever is earlier.

**28.00 PACKING**

28.01 The prepaid meter with communication module, CMRI etc. shall be suitably packed in order to avoid damage during transit or handling. Each meter and CMRI may be suitably packed in the first instance to prevent ingress of moisture and dust and then placed in a cushioned carton of a suitable material to prevent damage due to shocks during transit.

The lid of the carton may be suitably sealed. A suitable number of sealed cartons may be packed in a case of adequate strength with extra cushioning.

The cases may then be properly sealed against accidental opening in transit. The packing cases may be marked to indicate the fragile nature of the contents.

28.02 The following information shall be furnished with the consignment:

- (i) Name of the consignee
- (ii) Details of consignment

---

**TECHNICAL SPECIFICATION OF THREE PHASE 10-60 AMPS PREPAID METER**

---

- (iii) Destination
- (iv) Total weight of the consignment
- (v) Sign showing upper / lower side of the crate
- (vi) Sign showing fragility of the material
- (vii) Handling and unpacking instructions
- (viii) Bill of Material indicating contents of each package and spare material.

**29.00 QUALITY CONTROL**

29.01 The purchaser has a right to send a team of experienced engineers for assessing the capability of the firm for manufacturing and testing of meters as per this specification.

The team shall be given all assistance and co-operation for inspection and testing at the bidder's works.

29.02 Meters supplied shall give service for a long period without drifting from original calibration & performance must be near to zero percent failure.

**30.00 MINIMUM TESTING FACILITIES**

30.01 Manufacturer shall possess fully computerized automatic Meter Test Bench System having in-built constant voltage, current and frequency source with facility to select various loads automatically and print the errors directly for carrying out routine and acceptance Tests as per IS: 15884 / 2010 of the latest version. Test Reports for each and every meter shall be generated. The list of testing equipments shall be enclosed.

30.02 The manufacturer shall have the necessary minimum testing facilities for carrying out the following tests:

- a) Insulation resistance measurement
- b) No load condition
- c) Starting current
- d) Accuracy requirement
- e) Power consumption
- f) Repeatability of error
- g) Transportation test – as per clause no. 26.03(b)
- h) Tamper conditions - as per clause no.15.00
- i) Prepaid Feature Testing Facility as per clause no. 26.03 (a) &IS.

---

**TECHNICAL SPECIFICATION OF THREE PHASE 10-60 AMPS PREPAID METER**

---

- j) The manufacturer shall have duly calibrated RSS meter of class 0.1 or better accuracy.
- k) The manufacturer shall have Glow Wire Testing facility

**30.03 METER SOFTWARE**

The Bidders will have to get appraised & obtain Capability Maturity Model Integration CMMI – Level III as on the date of tender.

**31.00 MANUFACTURING ACTIVITIES**

The manufacturer shall submit the list of plant and machinery along with the offer.

A. Meter shall be manufactured using SMT (Surface Mount Technology) components and by deploying automatic SMT pick and place machine and reflow solder process. The loops/wired joints must be avoided on PCB. Further, the Bidder shall own or have assured access (through hire, lease or sub-contract, documentary proof shall be attached with the offer) of above facilities.

B. Quality shall be ensured at the following stages:

- a) At PCB manufacturing stage, each Board shall be subjected to computerized bare board testing.
- b) At insertion stage, all components shall undergo computerized testing for conforming to design parameter and orientation
- c) Complete assembled and soldered PCB shall undergo functional testing using Automatic Test Equipments(ATEs).

d) Important:

Prior to final testing and calibration, all meters shall be subjected to ageing test (i.e. Meters will be kept in heating chamber for 72 hours at 55° C temperature at full load current. After 72 hours, meter shall work satisfactory) to eliminate infant mortality.

C. The calibration of meter shall be done in-house on a computerized testing bench having stabilized power supply.

D. The bidders shall submit the list of all (imported as well as indigenous) components to be used in meter, separately along with the offer. List of makes of components is attached herewith as a guide line (Annexure -II).

E. Bought out items:

A detailed list of bought out items which are used in the manufacturing of the meter, shall be furnished indicating the name



**TECHNICAL SPECIFICATION OF THREE PHASE 10-60 AMPS PREPAID METER**

of firms from whom these items are procured. The bidder shall also give the details of quality assurance procedures followed by him in respect of the bought out items.

**F. List of Plant and Machinery used for Energy meter Production.**

<b>Sr. No.</b>	<b>List of Plant and Machinery used for Energy meter Production</b>	
1	Fully automatic testing Bench with ICT for testing link less meter	Routine Testing and Calibration of Meter
2	Semiautomatic Bench with MSVT testing	Routine Testing and Calibration of Meter
3	IR Tester	Insulation testing
4	HV Tester	Insulation testing
5	Error calculators	Error testing
6	Long duration Running test set ups	Reliability Testing
7	Reference Meter class 0.1 accuracy	Error calculation
8	Ultrasonic welding Machines	Welding of meter
9	Automatic Pick And Place Machines	Automatic placing of SMT components
10	Solder Paste Printing Machine	SMT soldering
11	Soldering Furnace IR reflow	SMT soldering
12	PCB Scanner	For testing of PCBs
13	ATE functional tester	For testing of Components
14	Programmings and Program Loaders	Chip Programming Tools

**TECHNICAL SPECIFICATION OF THREE PHASE 10-60 AMPS PREPAID METER**

15	CAD PCB designing setups	PCB designing
16	Furnace IR type for Hybrid Micro Circuits	resistance network and HMC manufacturing
17	Laser Trimming Machines	trimming of resistances for higher accuracy measurement
18	Wave Soldering Machines	Wave soldering of PCBs
19	Humidity Chamber	Accelerated testing for Life cycle
20	Dry Heat Test Chamber	Accelerated testing for Life cycle
21	Thermal Shock Chamber	Accelerated testing for Life cycle
22	PRO - E Mechanical Design Stations	Mechanical CAD stations
23	Spark Erosion Tool fabricating Machine	Tool fabrication and Die manufacturing
24	CNC wire Cut Tool Fabrication machine	Tool fabrication and Die manufacturing
25	CNC Milling Machine for composite tool fabrication	Tool fabrication and Die manufacturing
26	Injection Moulding Machine	Moulding of plastic parts
27	Vibration testing Machine	Vibration testing of Meter
28	Glow Wire Test machine	Testing of Plastic Material
29	Fast transient burst testing setup	Type testing of Meter
30	Short term over Current testing setup	Type testing of Meter

**TECHNICAL SPECIFICATION OF THREE PHASE 10-60 AMPS PREPAID METER**

31	Magnetic and other tamper testing setups	Tamper Testing
32	Impulse Voltage Testing Setup	Type testing of Meter
33	Composite Environmental testing chambers	Type testing of Meter

**32.00 QUALITY ASSURANCE PLAN**

- 32.01 The tenderer shall invariably furnish QAP as specified in Annexure - I along with his offer the QAP adopted by him in the process of manufacturing.
- 32.02 Precautions taken for ensuring usage of quality raw material and sub component shall be stated in QAP.

**33.00 COMPONENT SPECIFICATION**

As per Annexure - II enclosed.

**34.00 SCHEDULES**

The tenderer shall fill in the following schedules and submit along with the offer. If the schedules are not submitted duly filled in with the offer, the offer shall be rejected.

Schedule `A' .... Guaranteed Technical particulars (As per parameters uploaded on e - Tendering site.)

The discrepancies if any between the specification and the catalogs and/or literatures submitted as part of the offer by the bidders, the same shall not be considered and representations in this regard will not be entertained.

If it is observed that there are deviations in the offer in Guaranteed Technical Particulars other than those specified in the deviation schedules then such deviations shall be treated as deviations.

### **ANNEXURE - I**

#### **Quality Assurance Plan**

- A. The bidder shall invariably furnish the following information along with his bid, failing which his bid shall be liable for rejection. Information shall be separately given for individual type of material offered.
- i. Statement giving list of important raw materials, names of sub-suppliers for the raw materials, list of standards according to which the raw materials are tested. List of test normally carried out on raw materials in presence of Bidder's representative, copies of test certificates :
  - ii. Information and copies of test certificates as in (i) above in respect of bought out accessories.
  - iii. List of manufacturing facilities available.
  - iv. Level of automation achieved and list of areas where manual processing exists.
  - v. List of areas in manufacturing process, where stage inspections are normally carried out for quality control and details of such tests and inspections.
  - vi. List of testing equipment available with the bidder for final testing of equipment specified and test plan limitation. If any, vis-a-vis the type, special acceptance and routine tests specified in the relevant standards. These limitations shall be very clearly bought out in schedule of deviation from specified test requirements.
- B. The successful bidder shall within 30 days of placement of order, submit following information to the purchaser.
- i. List of raw materials as well as bought out accessories and the names of sub-suppliers selected from those furnished alongwith offers.
  - ii. Type test certificates of the raw materials and bought out accessories if required by the purchaser.
  - iii. Quality assurance plan (QAP) with hold points for purchaser's inspection. The quality assurance plant and purchasers hold points shall be discussed between the purchaser and bidder before the QAP is finalized.
- C. The contractor shall operate systems which implement the following:
- i. Hold point: A stage in the material procurement or workmanship process beyond which work shall not proceed without the documental approval of designated individuals organizations. The purchaser's

**TECHNICAL SPECIFICATION OF SERVICE MODULE LT AC THREE PHASE, 10 - 60 AMPS  
 PREPAID STATIC ENERGY METER AS PER IS: 16444 - 2015**

---

written approval is required to authorize work to progress beyond the hold points indicated in quality assurance plans.

- ii. Notification point: A stage in the material procurement or workmanship process for which advance notice of the activity is required to facilitate witness. If the purchaser does not attend after receiving documented notification in accordance with the agreed procedures and with the correct period of notice then work may proceed.

D. The successful bidder shall submit the routine test certificates of bought out accessories and central excise passes for raw material at the time of routine testing if required by the purchaser and ensure that Quality Assurance program of the contractor shall consist of the quality systems and quality plans with the following details.

- i. The structure of the organization.

The duties and responsibilities assigned to staff ensuring quality of work.

The system for purchasing taking delivery and verification of material.

The system for ensuring quality workmanship.

The system for retention of records.

The arrangement for contractor's internal auditing.

A list of administration and work procedures required to achieve and verify contract's quality requirements these procedures shall be made readily available to the project manager for inspection on request.

- ii. Quality Plans:

An outline of the proposed work and programme sequence.

The structure of the contractor's organization for the contract.

The duties and responsibilities assigned to staff ensuring quality of work.

Hold and notification points.

Submission of engineering documents required by the specification.

The inspection of materials and components on receipt.

Reference to the contractor's work procedures appropriate to each activity.

Inspection during fabrication / construction.

Final inspection and test.

**ANNEXURE - II**

**Component Specification**

The make/grade and the range of the components should be from the following list.

Sr. No	Component function	Requirement	Makes and Origin
1	Current Transformers	If the Meter is with one current transformers as measuring elements. The current transformer should withstand for the clauses under 5&9of IS-13779 /1999	ANY MAKE OR ORIGIN CONFORMING TO IS-2705 OR RELEVANT STANDARD.
2	Measurement	The measurement or computing chips used in the Meter should be with the Surface mount type along with the ASICs	USA: Analog Devices, Cyrus Logic, Atmel, Philips South Africa :SAMES Japan : NEC
3	Shunt Bimetal	E-beam welded shunts shall be provided in the phase element and CT/ Shunt / Hall effect sensor may be provided in the neutral. Alternatively, both the current elements (phase & neutral) shall have E-beam welded shunts with proper isolation	Redbourn Engg /Isabelle/
4	Quartz Crystal		AVX, VANLONG, ADVANCED CRYSTAL etc
5	Memory chips	The memory chips should not be affected by external parameters like sparking, high voltage spikes or electrostatic discharges.	USA: Atmel, National Semiconductors, Texas Instruments, Philips, ST, Japan :

**TECHNICAL SPECIFICATION OF SERVICE MODULELT AC THREE PHASE, 10 - 60 AMPS  
 PREPAID STATIC ENERGY METER AS PER IS: 16444 - 2015**

			Hitachi
6	Display modules	<p>a) The display modules should be well protected from the external UV radiations.</p> <p>b) The display visibility should be sufficient to read the Meter mounted at height of 0.5 meter as well as at the height of 2meters.</p> <p>c) The construction of the modules should be such that the displayed quantity should not be disturbed with the life of display( PIN Type).</p> <p>d) It should be trans- reflective HTN or STN type industrial grade with extended temperature range.</p>	<p>Display TEK/KCE/RCL Display / Suzhou heng Xiamen instruments/ Veritronics/ Bona- fide/ Jebon VIZ. Hongkong: Genda Singapore: Bonafied Technologies. Korea: AdvantekChina : Success Japan : Hitachi, Sony. TIANMA,Haijing, Holtek,</p>
7	Communication Modules	Communication modules should be compatible for the optical port for communication with meter reading instruments	<p>USA: National , Semiconductors HP, Optonica. Holland/ Korea : Phillips Japan : Hitachi Taiwan:Ligitek</p>
8	Optical port	Optical port should be used to transfer the meter data to meter reading instrument. The mechanical construction of the port should be such to facilitate the data transfer easily. The Optical Port should not be adversely affected by influence of electro magnetic field, Static discharge..	<p>USA: National Semiconductors HP Agilent Holland/Korea : Phillips Japan: Hitachi Taiwan: Ligitek</p>
9	Power supply	The power supply should	SMPS Type or

**TECHNICAL SPECIFICATION OF SERVICE MODULE LT AC THREE PHASE, 10 - 60 AMPS  
 PREPAID STATIC ENERGY METER AS PER IS: 16444 - 2015**

		Be with the Capabilities as per the relevant standards. It should not be affected in case the maximum voltage of the system appears to the terminals due to faults or due to wrong connections	better
10	Electronic components	The active & passive components should be of the surface mount type & are to be handled & soldered by the state of art assembly processes.	USA: National Semiconductors, Atmel, Philips, Texas Instruments, Siemens WELWYN, VISHAY DRALORIC, YAGEO ,KOA, R OHM, PHYCOMP, F AIRC HI LD, PHILIPS, VISHA Y SEMICON D, TEXAS INSTRUMENT, EPC OS, OSRAM, INFINION, NATI O NAL SEMICON D etc. Japan : Toshiba , Hitachi, Oki, AVZ or Ricon Korea; Samsung
11	Mechanical parts	a) The internal electrical components should be of electrolytic copper & should be protected from corrosion, rust etc. b) The other mechanical components should be protected from rust, corrosion etc. by suitable plating/painting methods.	



**TECHNICAL SPECIFICATION OF SERVICE MODULELT AC THREE PHASE, 10 - 60 AMPS  
PREPAID STATIC ENERGY METER AS PER IS: 16444 - 2015**

12	Battery	Chargeable maintenance free guaranteed life of 10 years.	Varta, Tedirun, Sanyo or National, Panasonic, Renata
13	RTC & Micro controller.	The accuracy of RTC shall be as per relevant IEC/ IS standards.	USA: Philips, Dallas, ST, Xicor Atmel, Motorola, Microchip Japan : NEC or Oki.
14	PCB	Glass Epoxy, fire resistance grade FR4, with minimum thickness 1.6mm.	A class vendor

**TECHNICAL SPECIFICATION OF SERVICE MODULE LT AC THREE PHASE, 10 - 60 AMPS  
 PREPAID STATIC ENERGY METER AS PER IS: 16444 - 2015**
**SCHEDULE 'A'**
**GUARANTEED TECHNICAL PARAMETERS**

<b>ITEM NAME</b>	<b>LT AC SINGLE PHASE, 10 -40 AMPS PREPAID STATIC ENERGY METER AS PER IS: 16444 - 2015 WITH COMMUNICATION MODULE FOR COMMUNICATION FOR USE ON LT CONSUMER INSTALLATIONS</b>	
<b>SR. NO.</b>	<b>GUARANTTED TECHNICAL PARAMETERS</b>	<b>GTP VALUES</b>
1.0	MAKE & TYPE	TEXT
2.0	APPLICABLE STANDARD	TEXT
3.0	ACCURACY CLASS 1.00 (YES/NO)	BOOLEAN
4.0	METER BEARS ISI MARK (YES/NO)	BOOLEAN
5.0	RATED VOLTAGE 240 V (YES/NO)	BOOLEAN
6.0	VOLTAGE RANGE (-) 40% TO (+) 20% OF RATED VOLTAGE (YES/NO)	BOOLEAN
7.0	FREQUENCY 50 HZ +/- 5% (YES/NO)	BOOLEAN
8.0	RATED BASIC CURRENT 10 AMPS (YES/NO)	BOOLEAN
9.0	MAXIMUM CONTINUOUS CURRENT I <sub>MAX</sub> 40 AMP (YES/NO)	BOOLEAN
10.0	METER WORKS ACCURATELY UPTO 120% OF I <sub>MAX</sub> , I.E. 48 AMPS (YES/NO)	BOOLEAN
11.0	STARTING CURRENT 0.2 % OF I <sub>B</sub> . (YES/NO)	BOOLEAN
12.0	POWER CONSUMPTION IN VOLTAGE CIRCUIT 5 W & 15 VA (YES/NO)	BOOLEAN
13.0	POWER CONSUMPTION IN CURRENT CIRCUIT 11.5 VA (YES/NO)	BOOLEAN
14.0	POWER FACTOR ZERO TO UNITY (ALL LAG OR LEAD) (YES/NO)	BOOLEAN

**TECHNICAL SPECIFICATION OF SERVICE MODULE LT AC THREE PHASE, 10 - 60 AMPS  
 PREPAID STATIC ENERGY METER AS PER IS: 16444 - 2015**

15.0	STANDARD REFERENCE TEMPERATURE FOR PERFORMANCE IS 27°C(YES/NO)	BOOLEAN
16.0	MEAN TEMPERATURE CO-EFFICIENT DOES NOT EXCEED 0.07%(YES/NO)	BOOLEAN
17.0	TEMPERATURE RISE IS AS PER IS: 15884 / 2010 OF THE LATEST VERSION. (YES/NO)	BOOLEAN
18.0	METER BASE & COVER MADE OF UNBREAKABLE, TOUGH, HIGH GRADE, FIRE RESISTANT TRANSPARENT POLYCARBONATE MATERIAL(YES/NO)	BOOLEAN
19.0	METER BODY TYPE TESTED FOR IP 51 DEGREE OF PROTECTION AS PER IS 12063 (YES/NO)	BOOLEAN
20.0	FURNISH PHYSICAL WATER ABSORPTION VALUE	TEXT
21.0	FURNISH THERMAL HDDT VALUE	TEXT
22.0	FLAMMABILITY V2 (YES/NO)	BOOLEAN
23.0	FURNISH FLAMMABILITY VALUE	TEXT
24.0	GLOW WIRE TEST AT 650° C	TEXT
25.0	TENSILE STRENGTH	TEXT
26.0	FLEXURE STRENGTH	TEXT
27.0	MODULUS OF ELASTICITY	TEXT
28.0	IZOD IMPACT STRENGTH NOTCHED 23° C	TEXT
29.0	FURNISH PHYSICAL WATER ABSORPTION VALUE	TEXT
30.0	TERMINAL BLOCK IS MADE FROM HIGH QUALITY NON-HYGROSCOPIC, FIRE RETARDANT, REINFORCED POLYCARBONATE (NON-BAKELITE) (YES/NO)	BOOLEAN
31.0	MATERIAL OF WHICH TERMINAL BLOCK IS MADE IS CAPABLE OF PASSING TESTS GIVEN IN IS: 13360 (PART 6/SEC 17) FOR A TEMPERATURE OF 135° C AND A PRESSURE OF 1.8 MPA (METHOD A)(YES/NO).	BOOLEAN

**TECHNICAL SPECIFICATION OF SERVICE MODULELT AC THREE PHASE, 10 - 60 AMPS  
 PREPAID STATIC ENERGY METER AS PER IS: 16444 - 2015**

32.0	EXTENDED TRANSPARENT TERMINAL COVER IS AS PER CLAUSE NUMBER 4.2.5 OF IS: 15884 / 2010 OF THE LATEST VERSION (YES/NO)	BOOLEAN
33.0	TRANSPARENT TERMINAL COVER IS SEALABLE INDEPENDENTLY(YES/NO)	BOOLEAN
34.0	PROPER SIZES OF GROOVES ARE PROVIDED AT BOTTOM OF TERMINAL COVER (YES/NO)	BOOLEAN
35.0	METER BASE & COVER ARE ULTRA-SONICALLY WELDED (CONTINUOUS WELDING)(YES/NO)	BOOLEAN
36.0	THICKNESS OF MATERIAL FOR METER 2 MM MINIMUM (YES/NO)	BOOLEAN
37.0	SCREWS USED ON TERMINAL COVER FOR FIXING & SEALING IN TERMINAL COVER ARE HELD CAPTIVE IN TERMINAL COVER (YES/NO)	BOOLEAN
38.0	TERMINALS ARE OF SUITABLE RATING & ARE CAPABLE OF CARRYING 120% OF I <sub>MAX</sub> & MADE OF ELECTRO-PLATED (OR TINNED) BRASS & ARE OF REPLACEABLE TYPE (YES/NO).	BOOLEAN
39.0	TERMINAL BLOCK, TERMINAL COVER, INSULATING MATERIAL RETAINING MAIN CONTACTS IN POSITION & METER CASE ENSURE REASONABLE SAFETY AGAINST SPREAD OF FIRE. THEY DO NOT IGNITE BY THERMAL OVERLOAD OF LIVE PARTS IN CONTACT WITH THEM (YES/NO).	BOOLEAN
40.0	MATERIAL OF TERMINAL BLOCK DOES NOT DEFLECT UNDER HEATING &. TO COMPLY THEREWITH, FULFILLS TESTS SPECIFIED IN 5.2.4 OF IS: 15884 / 2010 OF THE LATEST VERSION (YES/NO).	BOOLEAN
41.0	RTC PRE-PROGRAMMED FOR 30 YEARS DAY / DATE (YES/NO)	BOOLEAN
42.0	MAXIMUM DRIFT OF RTC	TEXT
43.0	RTC HAS LONG LIFE OF 10 YEARS (YES/NO)	BOOLEAN

**TECHNICAL SPECIFICATION OF SERVICE MODULE LT AC THREE PHASE, 10 - 60 AMPS  
 PREPAID STATIC ENERGY METER AS PER IS: 16444 - 2015**

44.0	PROVISION TO PUT AT LEAST TWO SEALS ON METER (YES/NO)	BOOLEAN
45.0	METER MEMORY HAS DETAILS AS PER CLAUSE NO. 6.16. (YES/NO)	BOOLEAN
46.0	NON-VOLATILE MEMORY IS FOR A MINIMUM PERIOD OF 10 YEARS (YES/NO)	BOOLEAN
47.0	OPERATION INDICATOR PROVIDED IN THE FORM OF BLINKING LED / LCD (YES/NO)	BOOLEAN
48.0	RESOLUTION OF TEST OUTPUTS SUFFICIENT TO CONDUCT SATISFACTORILY ACCURACY TEST AT LOWEST TESTPOINT IN LESS THAN 5 MIN & STARTING CURRENT TEST IN LESS THAN 10 MIN. (YES/NO)	BOOLEAN
49.0	METER CONSTANT INDELIBLY PROVIDED ON NAME PLATE (YES/NO)	BOOLEAN
50.0	PUSH BUTTONS ARRANGEMENT FOR HIGH RESOLUTION READING & SCROLLING THE PARAMETERS IN ALTERNATE DISPLAY (ON DEMAND) MODE	TEXT
51.0	METER ACCURACY DOES NOT GET AFFECTED BY MAGNETIC FIELD FROM ALL SIDES OF METER (YES/NO)	BOOLEAN
53.0	METER CAPABLE TO WITHSTAND PHASE TO PHASE VOLTAGE (440 V) IF APPLIED BETWEEN PHASE TO NEUTRAL FOR CONTINUOUSLY (YES/NO)	BOOLEAN
54.0	POWER SUPPLY UNIT IS TRANSFORMER LESS (YES/NO)	BOOLEAN
56.0	METER IS TAMPER PROOF & NO TAMPERING IS POSSIBLE THROUGH OPTICAL PORT (YES/NO).	BOOLEAN
57.0	DISPLAY PARAMETERS IN METER ARE NOT ACCESSIBLE FOR REPROGRAMMING AT SITE THROUGH ANY KIND OF COMMUNICATION (YES/NO).	BOOLEAN

**TECHNICAL SPECIFICATION OF SERVICE MODULET AC THREE PHASE, 10 - 60 AMPS  
 PREPAID STATIC ENERGY METER AS PER IS: 16444 - 2015**

58.0	COMPLETE METERING SYSTEM & MEASUREMENT NOT AFFECTED BY EXTERNAL ELECTROMAGNETIC INTERFERENCE AS PER CL. NO. 6.25 OF TECH. SPECS.(YES/NO)	BOOLEAN
59.0	METER MEETS REQUIREMENT OF CBIP TECH. REPORT 325 (YES/NO)	BOOLEAN
61.0	METER RECORDS AND DISPLAYS TOTAL ENERGY INCLUDING HARMONIC ENERGY(YES/NO).	BOOLEAN
62.0	METER PCB IS WIRELESS(YES/NO)	BOOLEAN
63.0	METER MANUFACTURED USING SMT (YES/NO)	BOOLEAN
64.0	METER IS CAPABLE OF BEING READ THROUGHIN BUILT COMMUNICATION MODULE AND OPTICAL PORT (YES/NO).	BOOLEAN
65.0	COMMUNICATION MODULE USED IN METER	TEXT
66.0	COMMUNICATION TECHNOLOGY ANF COMMUNICATION PROTOCOL USED TO TRANSFER DATA FROM METER TOSERVER	TEXT
67.0	CARRIER FREQUENCY USED FOR DATA COMMUNICATION	TEXT
68.0	BI-STABLE TYPE & MANUFACTURED IN ACCORDANCE WITH INTERNATIONAL STANDARD OF IEC & DIN EN 61810 PART 1 / VDE 0435 PART 201, TWO LATCHING RELAYS FOR PHASE & NEUTRAL ARE PROVIDED (YES/NO).	BOOLEAN
69.0	LATCHING RELAYS MEET OVERLOAD & SHORT CIRCUIT REQUIREMENT OF IEC, DIN EN 61036 / 61037 & ANSI C12 AND CONFIRM TO LOAD SWITCHING CAPABILITIES AS PER RELEVANT IS (YES/NO)	BOOLEAN
70.0	LATCHING RELAYS ARE WITH TRIP-FREE DESIGN AS PER IS (YES/NO).	BOOLEAN

**TECHNICAL SPECIFICATION OF SERVICE MODULELT AC THREE PHASE, 10 - 60 AMPS  
 PREPAID STATIC ENERGY METER AS PER IS: 16444 - 2015**

71.0	LATCHING RELAYS ARE DESIGNED & RATED TO MAKE & BREAK AT VREF, I <sub>MAX</sub> WITH A LINEAR RESISTIVE LOAD AND AT VREF, I <sub>B</sub> , 0.4 INDUCTIVE POWER FACTOR FOR 3,000 OPERATIONS(YES/NO).	BOOLEAN
72.0	AS THE BALANCE CREDIT DECREASES BEYOND PRE-DEFINED LEVEL, LATCHING RELAYS DISCONNECT SUPPLY TO LOAD (YES/NO).	BOOLEAN
73.0	METER DISCONNECTS LOAD IN CASE OF EXCEEDING CURRENT LIMIT (120% I <sub>MAX</sub> ) AFTER 1 MINUTEON STABILIZING THE CURRENT (YES/NO).	BOOLEAN
74.0	COMMUNICATION CAPABILITY OF METER IS BASED ON COMMUNICATION MODULE AND HARDWARE PORT COMPATIBLE WITH OPTICAL PORT SPECIFICATIONS (YES/NO).	BOOLEAN
75.0	COMMUNICATION MODULE IN METER IS ABLE TO TRANSFER DATA TO PREPAID ENGINE AND RECEIVE COMMANDS FROM PREPAID ENGINE (YES/NO)	BOOLEAN
76.0	METER HAS WIRED COMMUNICATION WITH OPTICAL PORT FOR DOWNLOADING ALL TYPES OF DATA FROM THE METER (YES/NO).	BOOLEAN
77.0	METER IS NOT ACCESSIBLE FOR REPROGRAMMING AT SITE THROUGH ANY KIND OF COMMUNICATION FOR ANY ALTERATION IN THE FACTORY SETTINGS (YES/NO).	BOOLEAN
78.0	OPTICAL PORT PROVIDED FOR DATA DOWNLOADING (YES/NO)	BOOLEAN
79.0	SEALING ARRANGEMENT FOR ABOVE PORTS IS PROVIDED(YES/NO)	BOOLEAN
80.0	OPTICAL PORT SUPPORT DEFAULT & MINIMUM BAUD RATE OF 9600 BPS (YES/NO)	BOOLEAN
81.0	TOD TIME ZONES PROVIDED (YES/NO)	BOOLEAN

**TECHNICAL SPECIFICATION OF SERVICE MODULELT AC THREE PHASE, 10 - 60 AMPS  
 PREPAID STATIC ENERGY METER AS PER IS: 16444 - 2015**

82.0	PROVISION TO SET MAXIMUM DEMAND INTEGRATION PERIOD AT 30 MINUTE AS PER REQUIREMENT (YES/NO).	BOOLEAN
83.0	AUTO RESET AT 24:00 HRS AT THE END OF EACH BILLING CYCLE OR AT THE END OF CERTAIN PREDEFINED PERIOD (SAY, END OF THE MONTH) IS PROVIDED (YES/NO)	BOOLEAN
84.0	AN LED FOR POWER ON INDICATION IS PROVIDED(YES/NO).	BOOLEAN
85.0	LED PROVIDED FOR POWER ON INDICATION BLINKS DURING COMMUNICATION(YES/NO).	BOOLEAN
86.0	DEBIT LIMIT UPTO FIVE DIGITS INR IS PROVIDED INTO PREPAID ENGINE(YES/NO)	BOOLEAN
87.0	METER IS CAPABLE TO UPDATE CREDIT BALANCE AND BALANCE UNITS VIA PREPAID APPLICATION AND OPTICAL PORT (YES/NO)	BOOLEAN
88.0	PREPAID APPLICATION IS ABLE TO CONFIGUREAMOUNT FOR ENERGY CHARGES, FIXEDCHARGES, TAXES ETC. AS PER TARIFF APPLICABLE(YES/NO)	BOOLEAN
89.0	METER DISCONNECTS OUTPUT SUPPLY WHEN CREDIT REACHES TO ZERO EXCEPT EMERGENCY CREDIT LIMIT(YES/NO)	BOOLEAN
90.0	PREPAID ENGINE IS CAPABLE TO CONFIGURE FOREMERGENCY CREDIT LIMIT BEFORE DISCONNECTIONOF OUTPUT SUPPLY AFTER END OF HAPPY HOURS(YES/NO)	BOOLEAN
91.0	PREPAID ENGINE IS ABLE TO EXPORT THE BILLINGDATA AS PER MSEDCL FORMAT GIVEN IN CLAUSE NO.11.10 (YES/NO)	BOOLEAN
92.0	ALL ANTI-TAMPER FEATURES AS PER CLAUSE 14.00 ARE PROVIDED (YES/NO)	BOOLEAN



**TECHNICAL SPECIFICATION OF SERVICE MODULELT AC THREE PHASE, 10 - 60 AMPS  
 PREPAID STATIC ENERGY METER AS PER IS: 16444 - 2015**

93.0	PERMANENT BACKLIT LCD TYPE DISPLAY IS PROVIDED(YES/NO)	BOOLEAN
94.0	5 NUMBER OF DIGITS FOR ENERGY DISPLAY PROVIDED(YES/NO)	BOOLEAN
95.0	MINIMUM SIZE OF DIGITS (10X5 MM) (YES/NO)	BOOLEAN
96.0	METER PRE-PROGRAMMED FOR (a) 240 V (YES/NO)	BOOLEAN
97.0	(b)INTEGRATION PERIOD OF 30 MIN FOR MD (YES/NO)	BOOLEAN
98.0	(c) AUTO RESET KWMD AT 2400 HRS. OF LAST DAY OF EACH CALENDAR MONTH(YES/NO)	BOOLEAN
99.0	(d) NO RESET PUSH BUTTON PROVIDED FOR MD RESET (YES/NO)	BOOLEAN
100.0	DISPLAY INDICATORS BY LED / LCD PROVIDED AS PER CLAUSE NO. 15.10 (YES/NO)	BOOLEAN
101.0	PARAMETERS IN AUTO SCROLL MODE DISPLAYED FOR MINIMUM 10 SECONDS INCLUDING LCD CHECK (YES/NO).	BOOLEAN
102.0	DEFAULT DISPLAY SWITCHES TO ALTERNATE DISPLAY AFTER PRESSING THE PUSH BUTTON CONTINUOUSLY FOR 5 SECONDS(YES/NO)	BOOLEAN
103.0	ALTERNATE DISPLAY SWITCHES TO DEFAULT DISPLAY IF PUSH BUTTON IS NOT OPERATED FOR 15 SECONDS(YES/NO)	BOOLEAN
104.0	KVA MD PROVIDED (YES/NO)	BOOLEAN
105.0	METER HAS NON-VOLATILE MEMORY FOR RECORDING HISTORY OF BILLING PARAMETERS FOR LAST 12 MONTHS (YES/NO).	BOOLEAN
106.0	PROVISION FOR LOAD SURVEY FOR 30 MINUTES & FOR LAST 60 POWER ON DAYS FOR SPECIFIED PARAMETERSON FIFO (YES/NO)	BOOLEAN

**TECHNICAL SPECIFICATION OF SERVICE MODULELT AC THREE PHASE, 10 - 60 AMPS  
 PREPAID STATIC ENERGY METER AS PER IS: 16444 - 2015**

107.0	METER RECORDS TAMPER EVENTS AS SPECIFIED IN SPECIFICATION (YES/NO).	BOOLEAN
108.0	METER KEEPS RECORDS FOR MINIMUM 100 EVENTS. (OCCURRENCE + RESTORATION) FOR ABNORMAL CONDITIONS ON FIFO BASIS (YES/NO).	BOOLEAN
109.0	IT IS POSSIBLE TO RETRIEVE ABNORMAL EVENT DATA ALONG WITH ALL RELATED SNAP SHOTS DATA THROUGH OPTICAL PORT AND UPLOAD THE SAME TO PREPAID APPLICATION(YES/NO)	BOOLEAN
110.0	METERING PROTOCOL TO BE IMPLEMENTED BY THE BIDDER	TEXT
111.0	PREPAID ENGINE IS ABLE TO SEND CONNECT/DISCONNECT SIGNAL TO COMMUNICATION MODULE IN METER ACCORDING TO BALANCE OF CONSUMER(YES/NO)	BOOLEAN
112.0	PERMANENT NATURE CONNECTION DIAGRAM OF METER IS SHOWN ON INSIDE PORTION OF TERMINAL COVER (YES/NO)	BOOLEAN
113.0	CLEARLY VISIBLE, EFFECTIVELY SECURED, INDELIBLY & DISTINCTLY MARKED NAME PLATE WITH ALL ESSENTIAL PARTICULARS AS PER RELEVANT STANDARD & SPECIFICATION IS PROVIDED (YES/NO)	BOOLEAN
114.0	METER IS TYPE TESTED (YES/NO)	BOOLEAN
115.0	TYPE TEST REPORT NUMBER & DATE OF METER	TEXT
116.0	GUARANTEE 5 YEARS FROM INSTALLATION OR FIVE & HALF YEARS FROM DATE OF DESPATCH (YES/NO)	BOOLEAN
117.0	15 NOS. OF SAMPLE METERS AS PER IS: 13779 / 1999 (AMENDED UPTO DATE) WITH COMMUNICATION MODULE FOR CONNECTIVITY AS PER TECHNICAL SPECIFICATION ALONG WITH CONNECTING TELEPHONIC CABLE WITH CONNECTORS FIXED TO CABLE, API / EXE FILE WITH DOCUMENTATION, BCS AND VENDING STATION SOFTWARE ETC IS SUBMITTED ALONGWITH OFFER (YES/NO).	BOOLEAN

**TECHNICAL SPECIFICATION OF SERVICE MODULE LT AC THREE PHASE, 10 - 60 AMPS  
 PREPAID STATIC ENERGY METER AS PER IS: 16444 - 2015**

118.0	IN HOUSE TESTING FACILITIES ARE AVAILABLE FOR (a) INSULATION RESISTANCE MEASUREMENT (YES/NO)	BOOLEAN
119.0	(b) NO LOAD CONDITION (YES/NO)	BOOLEAN
120.0	(c) STARTING CURRENT TEST (YES/NO)	BOOLEAN
121.0	(d) ACCURACY TEST REQUIREMENT (YES/NO)	BOOLEAN
122.0	(e) POWER CONSUMPTION (YES/NO)	BOOLEAN
123.0	(f) TRANSPORTATION TEST(YES/NO)	BOOLEAN
124.0	(g) FULLY COMPUTERISED METER TEST BENCH SYSTEM FOR CARRYING OUT ROUTINE AND ACCEPTANCE TEST IS AVAILABLE (YES/NO)	BOOLEAN
125.0	(h) MANUFACTURER HAS CALIBRATED STANDARD METER OF 0.1 CLASS ACCURACY(YES/NO)	BOOLEAN
126.0	(i) VERIFICATION OF DATA DOWNLOADING WITH COMMUNICATION MODULE(YES/NO)	BOOLEAN
127.0	(j) GLOW WIRE TESTING (YES/NO)	BOOLEAN
128.0	FURNISH PRINCIPLE OF OPERATION OF METER OUTLINING METHODS AND STAGES OF COMPUTATIONS OF VARIOUS PARAMETERS STARTING FROM INPUT VOLTAGE AND CURRENT SIGNALS INCLUDING SAMPLING RATE IF APPLICABLE (YES/NO)	TEXT
129.0	MANUFACTURING ACTIVITIES ARE AS PER CLAUSE 37.00 (YES/NO)	BOOLEAN
130.0	QAP SUBMITTED AS PER ANNEXURE-I (YES/NO)	BOOLEAN
131.0	AGEING TEST IS CARRIED OUT ON METER (YES/NO)	BOOLEAN
132.0	WHETHER YOU AGREE TO SUPPLY METERS AS PER ANNEXURE-D, I.E. TECHNICAL SPECIFICATIONS OF THE TENDER. (YES/NO)	BOOLEAN

# LIST OF SERVICES

SR. NO.	SERVICE NAME	ACTIVITY NUMBER	UOM	SAC CODE	REQ. QTY	VERSION	MATERIAL TYPE
1	Installation Commisioning of	PM.OTH.INS TALL	Activity unit	998736	150000		null

## Required Documents (To be uploaded online)

Sr. No.	NAME	SECTION	ITEM	DESCRIPTION
1	Annexure –VI : Price Bid Format	Price Section	Installation Commissioning	Annexure –VI : Price Bid Format
2	Documentary evidence for QAP of Technical Specification i.e. Annexure-D	Technical Section	Installation Commissioning	Documentary evidence for QAP of Technical Specification i.e. Annexure-D
3	Guaranteed Technical Parameters (GTP) as per Schedule-A of Technical Specifications	Technical Section	Installation Commissioning	Guaranteed Technical Parameters (GTP) as per Schedule-A of Technical Specifications
4	Annexure –II : For Authorized Assignee / Nominee in case of Foreign Bidder	Commercial Section		Annexure –II : For Authorized Assignee / Nominee in case of Foreign Bidder
5	Annexure –IV (A) : Proforma for Bid Security (EMD) Annexure –IV (B) : Proforma for Security / Perform	Commercial Section		Annexure –IV (A) : Proforma for Bid Security (EMD) Annexure –IV (B) : Proforma for Security / Performance Bank Guarantee
6	Annexure –V : Commitments of tenderer / contractor	Commercial Section		Annexure –V : Commitments of tenderer / contractor
7	Annexure –VII : No Deviation Proforma	Commercial Section		Annexure –VII : No Deviation Proforma
8	Annexure –VIII : Proforma for Service Level Agreement (SLA)	Commercial Section		Annexure –VIII : Proforma for Service Level Agreement (SLA)
9	Annexure –X : Check list	Commercial Section		Annexure –X : Check list
10	Annexure –XI : Milestone	Commercial Section		Annexure –XI : Milestone
11	Annexure – XII : Offered quantity	Commercial Section		Annexure – XII : Offered quantity
12	List of year wise, item wise orders executed and under execution duly certified by C.A.	Commercial Section		List of year wise, item wise orders executed and under execution duly certified by C.A.
13	Copy of latest turnover certificate for the product offered for last 3 years duly certified by Chart	Commercial Section		Copy of latest turnover certificate for the product offered for last 3 years duly certified by Chartered engineer/accountant
14	Notarized power of attorney in favor of appointed agent/representative.	Commercial Section		Notarized power of attorney in favor of appointed agent / representative.
15	Doc. evid. from NSIC/DIC of not crossed prescribed monetary limit/limit for invest. in plant &	Commercial Section		Doc. evid. from NSIC/DIC of not crossed prescribed monetary limit/limit for invest. in plant & m/c for mfg. entrp. resp. & are entitled for Tender fee/EMD exmpn(MSE cert /Notarized valid NSIC cert)

Sr. No.	NAME	SECTION	ITEM	DESCRIPTION
m/c f				
16	Doc. Evid. in respect of classification of your unit as per Micro, Small and Medium Enterprises Deve	Commercial Section		Doc. Evid. in respect of classification of your unit as per Micro, Small and Medium Enterprises Development Act 2006.
17	The bidder shall submit the undertaking certifying that you have not approached any one for undue in	Commercial Section		The bidder shall submit the undertaking certifying that you have not approached any one for undue influence
18	Annexure – I : Indemnity Bond for Foreign Bidder / Manufacturer	Commercial Section		Annexure – I : Indemnity Bond for Foreign Bidder / Manufacturer
19	ISO & BIS Certificates	Commercial Section		ISO & BIS Certificates
20	Doc. Evidence as per Cl. 2.4 of Section I i.e. Q.R.	Commercial Section		Doc. Evidence as per Cl. 2.4 of Section I i.e. Q.R.
21	Certificate duly certified by C.E./C.A. that the person/entity does not have controlling stake in mo	Commercial Section		Certificate duly certified by C.E./C.A. that the person/entity does not have controlling stake in more than one entity applied for the Tender/Bid.