



**Technical Specification of 5 MVA and 10 MVA Power Transformer**



Maharashtra State Electricity Distribution Company Limited

---

**SPECIFICATION NO.**

**T & Q C : MSC-I / 5 & 10 MVA Power Transformer //2019 /08**

TECHNICAL SPECIFICATION

FOR

5 MVA & 10 MVA, 33/11 kV, 33/22 kV & 22/11 kV

POWER TRANSFORMERS

FOR

DISTRIBUTION SYSTEM

IN

MSEDCL

**TECHNICAL SPECIFICATION NO.**

**T & Q C : MSC-I / 5MVA &10 MVA Power Transformer //2019 /03**

**I N D E X**

<b>Cl. No.</b>	<b>Contents</b>
1	Scope
2	System Particulars
3	Service Condition
4	Applicable Standards
5	Specific Technical Requirements for Mineral Oil Filled Power Transformer
6	General Technical Details
7	Minimum Protective devices on Power Transformer
8	Oil
9	Oil Preservation Equipment: Oil Sealing
10	Bushing Insulators and Terminals
11	Cable Box :
12	Marshalling Box Cubicle
13	Valves
14	Cable routing on Power Transformer
15	Radio Interference And Noise Level
16	Painting of transformer, Conservator, OLTC, Radiator, Marshalling box
17	Minimum Protective devices on Power Transformer
18	Nitrogen injection Fire Protection System (NIFPS)
19	Fittings and Accessories on Power Transformer
20	Tests
21	Rejection
22	Quality Assurance
23	Detail Progress Report
24	Drawing Approval
25	Stage Inspection
26	Final Inspection

**Technical Specification of 5 MVA and 10 MVA Power Transformer**

27	Challenge Testing
28	Guaranteed & Technical Particulars
29	Performance Guarantee
30	Cost Data Sheet
31	Schedules
32	Anx-I: Technical specification of Transformer oil
33	Anx-II: Technical specification of Nitrogen Injection Fire Protection System

**Technical Specification of 5 MVA and 10 MVA Power Transformer**

**MAHARASHTRA STATE ELECTRICITY DISTRIBUTION CO. LTD.**

**TECHNICAL SPECIFICATION FOR**

**5MVA &10 MVA 33/11 kV, 33/22 kV & 22/11 kV**

**POWER TRANSFORMERS**

**SPEC. NO.T &Q C : MSC-I /5 MVA & 10 MVA Power Transformer //2019 /08**

**1 Scope:-**

- 1.1 This specification covers design, manufacturing, testing and delivery of Oil immersed, Oil Natural Air Natural (**ONAN**) Outdoor Type, Three Phase, 50 Hz,20 MVA 33/11 kV, 33/22 kV & 22/11 kV Step Down Power Transformers with On Load Tap Changer (**OLTC**) and Remote Tap Change Control (**R.T.C.C.**) panel, to be used in Sub Transmission/ Distribution system.
- 1.2 The equipment offered shall be complete with all parts necessary for their effective and trouble-free operation. Such parts will be deemed to be within the scope of the supply irrespective of whether they are specifically indicated in the commercial order or not.
- 1.3 It is not the intent to specify herein complete details of design and construction. The equipment offered shall conform to the relevant standards and be of high quality, sturdy, robust and of good design and workmanship complete in all respects and capable to perform continuous and satisfactory operations in the actual service conditions at site and shall have sufficiently long life in service as per statutory requirements. The dimensional drawings attached with this specification and the notes thereto are generally of illustrative nature. In actual practice, notwithstanding any anomalies, discrepancies, omissions, incompleteness, etc. in these specifications and attached drawings, the design and constructional aspects, including materials and dimensions, will be subject to good engineering practice in conformity with the required quality of the product, and to such tolerances, allowances and requirements for clearances etc. as are necessary by virtue of various stipulations in that respect in the relevant Indian Standards, IEC standards, I.E. Rules, I.E. Act and other statutory provisions.
- 1.4 The Tenderer/supplier shall bind himself to abide by these considerations to the entire satisfaction of the purchaser and will be required to adjust such details at no extra cost to the purchaser over and above the tendered rates and prices.
- 1.5 Tolerances:  
Tolerances on all the dimensions shall be in accordance with provisions made in the relevant Indian/IEC standards and in these specifications. Otherwise the same will be governed by good engineering practice in conformity with required quality of the product.

**Technical Specification of 5 MVA and 10 MVA Power Transformer**

**2 System Particulars:-**

- |      |   |   |  |       |      |
|------|---|---|--|-------|------|
| 2.1  | Nominal System Voltage  | : | 33 kV  | 22 kV | 11kV |
| 2.2  | Voltage variation on supply side  | : | ± 10 %   |       |      |
| 2.3  | Corresponding Highest System Voltage  | : | 36 kV  | 24 kV | 12kV |
| 2.4  | Frequency   | : | 50 Hz with ± 3 % tolerance   |       |      |
| 2.5  | Transient condition   | : | -20 % or + 10 % combined variation of voltage and frequency.   |       |      |
| 2.6  | Number of Phase   | : | 3  |       |      |
| 2.7  | Neutral earthing  | : | Solidly earthed.   |       |      |
| 2.8  | Short circuit withstand level   | : | 31.1 KA for 2 Sec for 22 kV and 33 kV<br>13.1 KV for 2 sec for 11 KV and 22kV  |       |      |
| 2.9  | Over voltage operating capability and duration  | : | 112.5 % of rated voltage(continuous)   |       |      |
| 2.10 | Noise level(As per IEC:551 and NEMA)<br>(Noise level shall not exceed limits as per NEMA TR – 1.) | : | 65db for 5 MVA and 69db for 10 MVA   |       |      |
| 2.11 | Rated Lightning Impulse withstand<br>Voltage kV Peak for 33/ 22 kV system.                        | : | 170 kV   |       |      |
| 2.12 | Rated Lightning Impulse withstand<br>Voltage, kV Peak for 11 kV system.                           | : | 75 kV  |       |      |
| 2.13 | Rated short duration Power frequency<br>Withstand voltage, kV rms 33/ 22 kV system                | : | 70 kV  |       |      |
| 2.14 | Power frequency withstand voltage<br>kV rms 11 kV system  | : | 28 kV  |       |      |
| 2.15 | System fault level for 33 / 22 kV   | : | 1500 MVA   |       |      |
| 2.16 | System fault level for 11 kV  | : | 500 MVA  |       |      |
| 2.17 | Harmonic current  | : | Designed for suppression of 3 <sup>rd</sup> , 5 <sup>th</sup> , 7 <sup>th</sup> Harmonic voltages and high frequency disturbances. |       |      |

**Technical Specification of 5 MVA and 10 MVA Power Transformer**

**3. Service Conditions:**

A) The 5 MVA and 10 MVA Power Transformers to be supplied against this specification shall be suitable for satisfactory continuous operation under the following tropical conditions.

3.1	Maximum ambient temperature (Degree C)	50
3.2	Maximum temperature in shade	45
3.3	Minimum Temperature (Degree C)	3.5
3.4	Relative Humidity (percent)	100 %
3.5	Maximum Annual rain fall (mm)	1450
3.6	Maximum wind pressure (kg/sq.m)	150
3.7	Maximum altitude above mean sea level ( Meter)	1000
3.8	Isoceranic level (days per year)	70
3.9	Seismic level (Horizontal Acceleration)	0.3 g
3.10	Climatic Condition	Moderately hot and humid tropical climate conducive to rust and fungus growth.

B) The climatic conditions are prone to wide variations in ambient conditions and hence the equipment shall be of suitable design to work satisfactorily under these conditions.

**4. Applicable Standards:**

4.1 Unless otherwise modified in this specification the transformers shall comply with the Indian Standard Specification IS: 2026 latest or relevant International Standard such as ANSI, OSA, DIN, IEC etc., acceptable to the purchaser. The specified equipments are of standard industrial type and can be supplied by manufacturers active in the international market.

4.2 Equipment meeting with the requirements of other authentic standards, which ensure equal or better quality than the standards mentioned above, shall also be considered. Two copies of such standards, in authentic English translation shall be furnished along with the offer.

4.3 Equipment offered shall comply with all currently applicable statutory requirements, regulations and safety codes applicable for design, quality of material and construction manufacture, inspection and performance.

4.4 In case of conflict arising out due to variations between the applicable standard and The standards specified herein the provisions of this specification shall prevail.

**Technical Specification of 5 MVA and 10 MVA Power Transformer**

Sr. No.	Applicable Standards	Details
1.	IS : 2026	Power Transformer
2.	IEC : 60076	
3.	IEC : 60354	Loading guide for oil immersed Power Transformer. IS: 2026-7
4.	IS : 2026-7, IS : 6600	
5.	IEC : 60551	Determination of sound levels of Transformer and reactors.
6.	IEC : 60214	On load tap changer.
7.	IS : 8468	
8.	IEC : 60156	Method for determination of the electric strength for insulating oils.
9.	IEC : 60296	Specification for unused Mineral insulating oils for Transformer and switchgear.
10	IS : 335:2018 (vth Revision )	New Insulating oil.
15.	IEC : 60606	Application guide for Power Transformer.
16	IS : 3639	Fitting and accessories for Power Transformer
17	IS : 10028	Code of practice for selection, installation and maintenance of transformer.
18.	IEC : 60616	Terminal and tapping marking for Power Transformer.
19.	IEC : 60445	Basic and safety principle for man-machine interface, marking and identification of equipment terminal and conductor termination.
20,	IS :5561	Electrical power connectors.
21.	IS :1271	Thermal evaluation and classification of electrical insulation
22.	IEC : 60071	Co-ordination of insulation.
23.	IEC : 60034	Rotating electrical machines.
24.	IEC : 60947	Low voltage switchgear and control gear.
25.	IS : 13947	LV switchgear and control gear- Part : 1.
26.	IS :325	Three phase induction motors.
27.	IS :6272	Industrial cooling fans.
28.	BS : 2562	Cable boxes for transformers and reactors. As per CBIP-317-2013)
29.	IEC : 60137	Bushing for alternating voltages above 1000V.
30.	BS : 223	
31.	IS :2099	
32.	IS :3347	Dimensions for Porcelain Transformer bushing.

**Technical Specification of 5 MVA and 10 MVA Power Transformer**

33.	IEC : 60529	Degrees of protection for enclosures.( IP).
34.	IS :3347	Gas operated relays.
35.	IS : 5	Colors for ready mix.
36.	IS : 3034	High velocity water spray system.
37.	IS : 1239	Heavy seamless Carbon steel pipe.
38.	IS : 14846	Sluice / Gate valve.
39.	National Fire Protection Association (National Fire code 1993) NFPA, USA.	
40.	Loss Prevention Association.(LPA)	
41.	Indian Electricity Rules.	
42.	Indian Electricity Act.	
49.	CBIP Manual.-295	

If the standard is not quoted for any item, it shall be presumed that the latest version of Indian Standard shall be applicable to that item.

Equipment meeting with the requirements of other International standards which ensure equal or better performance than the standards mentioned above shall also be considered. When the equipment offered by the supplier conforms to other standards, salient points of difference between standards adopted and the standards specified in this specification shall be clearly brought out in the offer. Two copies of such standards with authentic translation in English shall be furnished along with the offer.

**5.0 Specific Technical Requirements for Mineral Oil filled Power Transformer:**

5.1 **Standard MVA Ratings:-** 5 MVA and 10 MVA (Continuous capacity).

5.2 **Rated Voltage :**

i. Primary Voltage - 33 kV or 22 kV

ii. Secondary voltage - 22 kV or 11 kV

5.3 **Temperature Rise:**

i. The temperature rise for top oil over an ambient temperature of 50 °C should be 50 °C maximum (measured by thermometer in accordance with IS 2026 or relevant International Standard).

ii. Temperature rise for winding over an ambient temperature of 50 °C should be 55 °C maximum (measured by resistance in accordance with IS 2026 or relevant International Standard).

5.4 **System Earthing:**

Neutral of LV side to be solidly earthed

5.5 **No Load voltage ratio:-**

The No Load Voltage ratio corresponding to the principal tapping shall be 33,000/11,000 Volts, 33000/22000 Volts or 22,000/11,000 Volts.



**Technical Specification of 5 MVA and 10 MVA Power Transformer**

**5.6 Flux density:-**

Flux density should not be more than **1.69** Tesla Transformer core should be designed in such a way that it will not get saturated for any value of V/f (Voltage/frequency) ratio to the extent of 112.5% of rated value of V/f ratio (i.e. 11000/50, 22000/50, 33000/50). Actual core design along with calculations in support of it should be enclosed with the offer.

**5.7 Current Density:**

The current density for HV & LV windings should not exceed 2.8 A / mm<sup>2</sup> for electrolytic copper conductor at any working tap including extreme tap 17 (-15% voltage).

**5.8 Magnetizing Current:-**

- i. The magnetizing current at normal voltage & frequency shall be limited to 1% of full load current.
- ii. The magnetizing current at maximum voltage & frequency shall be limited to 3% of full load current.

**5.9 Impedance Values :**

Percentage impedance voltage on normal taps & rated MVA at 75° C.

Base MVA	% impedance	IS Tolerance
5	7.15 %	± 10%
10	8.35 %	± 10%

**5.10 Minimum clearances:**

Following minimum clearances in air and oil shall be maintained:

Voltage	Phase to phase (in mm)	Phase to Earth out of Oil (in mm)	Phase to Earth in Oil (in mm)
11 KV	280	140	25
22 KV	400	320	40
33 KV	400	320	40

**5.11 Losses:**

The losses shall not exceed the value given below

Voltage Ratio	No load Losses(fixed) (KW)	Load Losses (kW at 75 ° C)	No load Losses (fixed) (KW)	Load Losses (kW at 75 ° C)
	5 MVA		10MVA	
33/11	4	23	7	50
33/22	4	23	7	50
22/11	4	23	7	50

## Technical Specification of 5 MVA and 10 MVA Power Transformer

5.12 **Vector Group :** Dyn 11

5.13 **Anticipated unbalanced loading :**  $\pm 10 \%$

5.14 **Anticipated continuous loading of winding (HV/LV) :** 110 % of rated current

### **6.0 General Technical Details:**

#### **6.1 Core :-**

- a) Material to be used for the transformer core shall be made of premium grade Imported Cold Rolled Grain Oriented (CRGO) M4 or better with high grade, non-ageing, low loss and high permeability cold rolled grain oriented silicon steel laminations. Only those bidders who directly imported CRGO either from the manufacturer or through their accredited marketing organization of reputed (and not through any agent) shall be considered. In support of this requirement the bidder shall submit an undertaking in specified format (schedule C) in the form.
- b) The CRGO shall be cut at Mill's authorized Processing unit only.
- c) Lamination thickness should be maximum 0.27 mm with insulation coating on both sides.
- d) Flux density should not exceed **1.69** Tesla at rated voltage and frequency. Flux density should not exceed **1.9** Tesla at 112.5 % of rated voltage and frequency
- e) The design of the magnetic circuit shall be such as to avoid static discharges, development of short circuit paths within itself or to the earthed clamping structure and production of flux component at right angles to the plane of laminations which may cause local heating.
- f) The Core design shall be compact with least possible air gap and rigid clamping for minimum core loss and noise generation.
- g) Core shall be adequately braced to withstand bolted faults on secondary terminals without mechanical damage and displacement during transportation and positioning.
- h) All steel sections used for supporting the core shall be thoroughly sand blasted after cutting, drilling and welding
- i) Each core lamination shall be insulated with a material that will not deteriorate due to pressure and hot oil
- j) The supporting frame work of core shall be so designed as to avoid presence of pockets which would prevent complete emptying of the tank through drain valve or cause trapping of air during oil filling.
- k) The bidder shall provide saturation curve of the core material proposed to be used and calculations.
- l) Adequate lifting lugs shall be provided to lifting the core coil assembly.
- m) The framework and clamping arrangements shall be earthed.
- n) Insulation of Core to bolt and core to clamps shall be able to withstand a voltage.
- o) The core shall be bolted to the bottom plate of the tank secularly.
- p) Suitable magnetic shunts may be provided at the tank wall.

## **Technical Specification of 5 MVA and 10 MVA Power Transformer**

The successful bidder, shall be required to submit the manufacturer's test report showing the Watt Loss per kg and the thickness of the core lamination, to ascertain the quality of Core materials.

The purchaser reserves the right to get sample of the core material tested at any Government recognized laboratory.

### **6.2 Windings:**

- a) The supplier shall ensure that windings of the transformers are made in dust proof environment. The conductors shall be of Electrolytic Grade copper as per relevant standard.
- b) The Class 'A' insulation of transformer windings and connections shall be free from compounds which are liable to ooze out, shrink or collapse and shall be non catalytic in transformer oil during service. The winding insulation shall be uniform.
- c) Coil assembly and insulating spacers shall be so arranged as to ensure free circulation of oil and to reduce the hot spot of the winding.
- d) The conductors shall be transposed at suitable intervals in order to minimize eddy current and to equalize the distribution of current and temperature along the windings.
- e) The windings shall be so designed that all coil assembly of identical voltage rating shall be interchangeable
- f) Insulation of HV and LV winding shall be adequate to withstand surge voltages appearing across them as a result of transfer due to an impulse striking on HV and LV terminals.
- g) Adequate shrinkage to stack of coil should be carried out before final assembly.
- h) Connection shall be braced to withstand shock during transport, switching, short circuit or other transients.
- i) At all voltage ratios there shall be minimum out of forces in the transformer winding.
- j) Threaded connection with locking facility and transported at sufficient intervals.
- k) Provision of taps as per requirement.
- l) Core coil assembly shall be mounted on bottom of tank. Earthing of core clamping Structure and Earthing of magnetic circuit shall be in line with CBIP manual.

### **6.3 Tank:**

- a) The transformer tank and cover shall be fabricated from good, commercial grade, low carbon robust mild steel plate of tested quality. The thickness of side wall should be minimum 10 mm and minimum 12 mm for top and bottom cover, adequate for meeting the requirement of pressure and vacuum type tests as per CBIP. Test will be conducted on each transformer tank for design validation.
- b) The tank shall be of welded construction. All seams and those joints not required to be opened at site shall be double welded. All welding shall be stress relieved for sheet greater than 35mm. All pipes, stiffeners etc, shall be welded

### Technical Specification of 5 MVA and 10 MVA Power Transformer

externally. The tank stiffeners shall be adequately sloped to prevent accumulation of water. The tank shall have sufficient strength to withstand without permanent distortion under following conditions:

- i. Oil filling under vacuum.
  - ii. Continuous internal gas pressure of **35 kN/m<sup>2</sup>** with oil at operating level and
  - iii. Normal Mechanical shock during transportation, jacking, loading and unloading operations.
- c) There shall be adequate space for collection of sediments at the bottom of tank. Tank bottom with welded skid base.
  - d) There shall not be any internal pockets in which gas / air can accumulate and external pocket in which water can lodge.
  - e) The tank cover shall be bolted to the tank and minimum disconnection of pipe work and accessories for cover lifting.
  - f) The tank of the transformer shall be complete with all accessories and shall be designed so as to allow the complete transformer filled with oil to be lifted by crane or jack transported by road, rail or water way without over straining any joints and without causing subsequent leakage of oil.
  - g) The main tank body excluding tap changing compartments and radiators shall be capable of withstanding a vacuum of **68 kN/m<sup>2</sup>** (500 mm of Hg.).
  - h) The base of each tank shall be so designed that it shall be possible to move the complete transformer unit by skidding on plates or rails in any direction without injury.
  - i) Suitable guides shall be provided in the tank for positioning the core and coil assembly.
  - j) All Control cabinets and marshaling kiosks being supplied as transformer accessories, except OLTC. Remote control panel shall be preferably mounted on the transformer body. No cabinet or marshaling kiosk shall be mounted on radiators.
  - k) Top of the tank cover shall be sloped towards HV side by approximately upto 10° to prevent retention of rainwater.
  - l) The thermometer pockets shall be fitted with captive screwed top to prevent the ingress of water.
  - m) The thermometer pockets shall be located in the position of maximum oil temperature at continuous and it shall be possible to remove the instrument bulbs without lowering the oil in the tank.
  - n) Inspection covers (Manhole) shall be rectangular in shape and flanged adequately. The tank cover and the inspection covers (Manhole) shall be provided with suitable lifting arrangements. Inspection covers (Manhole) shall not weigh more than 25 Kg each. Sufficient size of Inspection covers (Manhole) shall be provided for inspection of core and winding. Overall design shall be in such a way that there shall not be any hindrance / overlapping of some other component in front of the Inspection covers (Manhole).
  - o) Tank to be design for oil filling under vacuum.
  - p) Core, frame and tank earthing links shall be provided on tank top with the help of epoxy housing and shorted with links in normal operating condition.

## Technical Specification of 5 MVA and 10 MVA Power Transformer

### 6.4 Main Conservator tank:-

- a) Conservator should be volumetric capacity of at least 10 % of total volume of oil in the tank. Moreover the oil in conservator up to the minimum level mark on the oil level gauge should be at least 3 % of the total volume of oil in the transformer excluding oil in the OLTC. Conservator having a capacity between the highest and the lowest visible levels to meet the requirement of expansion of the total cold oil volume in the transformer and cooling equipment from the minimum ambient temperature i.e.  $-5^{\circ}\text{C}$  to  $98^{\circ}\text{C}$ .
- b) Flexible rubber bag (Air cell) should be provided inside of conservator tank for oil preservation system. Air cell material shall be special type of fabric coated with special grade nitrile rubber whose outer surface is oil resistant and inner surface is ozone resistant. It shall be possible to remove or replace the Air cell if required.
- c) Conservator shall be bolted into position so that it can be removed for easy cleaning and other maintenance work. Main pipe from tank shall be projected about 20 mm above conservator bottom for creating a sump for collection of impurities. Minimum oil level in conservator corresponding to minimum temperature shall be well above the sump level.
- d) Conservator shall be supported at minimum two points to Main tank.
- e) Conservator shall be mounted in such a way that the top cover of the transformer can be lifted without disturbing the conservator.
- f) Following fittings and accessories shall be provided on Main tank conservator:
  - i) Prismatic oil gauge with three position Normal, Minimum and Maximum marking.
  - ii) End cover.
  - iii) Oil feeling hole with cap.
  - iv) Magnetic Oil gauge with LOW LEVEL alarm.
  - v) Silica Gel Dehydrating Breather with oil seal and filter . Container and oil cup should be polycarbonate single piece clearly transparent cover and resistant to UV rays.
  - vi) Drain cum filling valve (Gate valve with locking rod and position indicator, made of Brass 25 mm with cover plate.
  - vii) Shut off valve (Gate valve) with position indicator made of Brass 80 mm located before and after Bucholz relay.
  - viii) Flange for Breather connection.
  - ix) Air release valve on conservator made of Brass 25 mm with cover plate.
- g) Breather body should be Aluminum pressure die cast, shot blasted and powder coated. Container and oil cup should be 143R grade UV resistant polycarbonate. All gaskets should be of nitrile cork (RC 70C) rubber. Breather should be flanged type . Breather piping shall not any valve placed in between conservator and breather. Breather shall be removable type mounted at suitable height from ground level. Breather shall be tested for 0.35 kg / cm for all joints. Silica Gel used in breather should be 2.5 mm diameter ROUND BALL type and should be bio-degradable, non- carcinogenic.

## Technical Specification of 5 MVA and 10 MVA Power Transformer

### 6.5 Radiator Arrangement:

A) Radiators shall be so designed as to avoid pockets in which moisture may collect and shall withstand the pressure tests B. Unless the pipe work is shielded by adequate earthed metal the clearance between all pipe work and live parts shall be more than the clearance for live parts to earth. Material for radiators shall be pressed steel or Stainless steel and thickness of material shall be 1.25 mm minimum.

- i. Each radiator block shall have shut off valves, lifting lugs, top and bottom oil filling valves, air release plug, a drain valve (25 mm) and fitted with captive screw cap on the inlet and outlet.
- ii. Each radiator shall be provided with:
  - a) One shut off valve at the top (80 mm size)
  - b) One shut-off valve at the bottom (80 mm size)
  - c) Air release device at the top
  - d) Drain plug at bottom
  - e) Lifting lugs.
  - f) Expansion bellows to be provided in pipes between main tank and radiator headers. Top plate of tank cover shall be easily removable at site hence radiator header pipe shall not originate from top cover of transformer.
  - g) Radiator support from ground if required.

B) Radiator accessories:

2 No's of radiators with top and bottom shut-off-valves, air release plug and drain plug, Air release device. The no. of radiators/fins and heat dissipation calculation to justify the no. of radiators shall be submitted along with the offer.

### 6.6 On Load Tap Changer:

#### 6.6.1) General Requirement:

External to tank. Each transformer shall be provided with voltage control equipment of the tap changing type for varying its effective transformation ratio whilst the transformers are on load.

- a) **Type:** External to tank type OLTC, Mineral oil
- b) **OLTC Location:** External to tank type OLTC- Side mounted on conservator side not in front of HV bushing and OLTC gear shall be covered with protective gear shaft around it.
- c) **Operation of OLTC gear :** The tapping shall be controlled by a high speed resistor transition type gear in which tap change is carried out virtually under 'No volt' " No ampere" condition. The selector switches do not make and break any current, main current is never interrupted and a resistor is provided to limit the arcing at diverted contacts to minimum suitable for outdoor mounting and continuously rated for operating at all positions including position in the middle of tap change. Selection of Local / Remote operation of OLTC gear is by selector switch on OLTC drive mechanism.

### **Technical Specification of 5 MVA and 10 MVA Power Transformer**

Local operation from OLTC drives mechanism through pistol grip rotary switch as well as emergency mechanical hand operation.

Remote operation from Digital RTCC provided by MSEDCL or SCADA depending on the selection of control on Digital RTCC panel.

**Safety interlocks:** Following minimum safety interlocks to be provided in OLTC:

- 1) Positive completion of tap changing step once initiated.
  - 2) Blocking of reverse tap change command during a forward tap change already in progress until the mechanism resets and vice-versa.
  - 3) Cutting of electrical circuits during mechanical operation.
  - 4) Mechanical stop to prevent overrunning of the mechanism at the end taps.
  - 5) Raise / Lower command in OLTC and Digital RTCC shall be positively interlocked.
- d) OLTC gear shall be motor operated suitable for local as well as remote operation. An external hand wheel/ handle shall be provided for local manual operation. This hand wheel/ handle shall be easily operable by a man standing at ground level.
- e) Arrangement shall be made for securing and padlocking the tap changer wheel in any of the working positions and it shall not be possible for setting or padlocking the wheel in any intermediate position. The arrangement shall be such that no padlock key can be inserted unless all contacts are correctly engaged and switch set in a position where no open or short circuit is possible. An indicating device shall be provided to show the tap in use.
- f) The details of the method of diversion of the load current during tap changing, the mechanical construction of the gear and the control features for OLTC gear along with detailed drawings on the inner view and the arrangement of connections, shall be submitted with the bid. Information regarding the service experience on the gear and a list of important users shall be furnished. The tap changer shall change the effective transformation ratio without producing phase displacement.
- g) The current diverting contacts shall be housed in a separate oil chamber not communicating with the oil in main tank of the transformer.
- h) **Tapings :** The transformers with on load taps shall have taps ranging from +5% to -15% in 16 equal steps of 1.25% each on HV winding (17 position) for HV variation for constant voltage on LV side. The transformer shall be capable of being operated without danger on any tapping at the rated 5 or 10 MVA with voltage variation of  $\pm 10\%$  corresponding to the voltage of that tapping. 9<sup>th</sup> tap, + 3.6 to -7.2 @ 1.2+5.4 to -10.8 @ 1.8.
- i) **OLTC features :**  
OLTC mechanism and associated controls shall be housed in an outdoor with IP 55, weatherproof, vermin proof and dust proof cabinet.  
It shall be ensured that oil in compartments containing contacts making and breaking current and Main transformer tank should not mix.  
The hand cranking arrangement shall be such that it can be operated at standing height from ground level.

**Technical Specification of 5 MVA and 10 MVA Power Transformer**

- j) Bill of Material for OLTC mechanism :** Drive Mechanism shall be of MA 9 with stainless steel enclosure.
- 1) Control circuit transformer 433/55,0-55 V, adequate capacity.
  - 2) Local / Remote selector switch 1 phase, 2 way, 6 Amp, Pistol grip.
  - 3) Retaining switch Raise / Lower.
  - 4) Handle interlock switch.
  - 5) Raise / Lower switch 1 phase, 2 way, 6 Amp, Pistol grip.
  - 6) Lower limit switch.
  - 7) Raise limit switch.
  - 8) Tap Changer Motor 433 V AC, 3 phase, adequate rating.
  - 9) Motor protection relay with single phasing preventer.
  - 10) Motor control contactors Raise / Lower.
  - 11) Stepping relay.
  - 12) Out of step switch.
  - 13) Tap position indicator.
  - 14) Operation counter.
  - 15) Emergency stop Push Button.
  - 16) Pressure relief valve and Oil surge relay should be provided to OLTC.
  - 17) Drive Mechanism box shall be either Stainless steel 314 or better or Aluminum pressure diecasted only.
  - 18) OLTC timer scheme to trip MPCB for continuous tap operation.
  - 19) Potential free contacts for OLTC supply Healthy, OLTC control supply Healthy, Tap change in progress and OLTC timer trip.
  - 20) All disconnecting type terminals shall be of POLYAMIDE stud type and screwdriver operated minimum 8 mm width.
  - 21) Drive Mechanism accessories :
    - a) Cubicle lamp with door switch and separate fuse / MCB with external ON / OFF switch on front of cover of OLTC drive mechanism.
    - b) Approved space heaters controlled by thermostat and separate fuse / MCB.
    - c) Incoming Fuse / MCB for incoming supply.
    - d) Panel wiring diagram fixed on back of panel door Aluminum engraved plate fixed with rivet.
    - e) Nylon 66 Terminal block minimum 4 sq. mm screw type with 10 % spare terminals.
    - f) Stainless steel door handle with lock and additional facility for padlock.
    - g) Earthing boss.
- k)** Separate conservator should be there for OLTC. Main tank conservator should not be used for OLTC.
- l)** The contacts shall be accessible for inspection without lowering oil level in the main tank and the contact tips shall be replaceable.
- m)** The Contractor shall indicate the safeguards in order to avoid harmful arcing at the current diverting contacts in the event of operation of the OLTC gear under over-load



### **Technical Specification of 5 MVA and 10 MVA Power Transformer**

conditions of the transformer. Necessary tools and tackles shall be provided along with main supply for maintenance of OLTC gear.

- n) The OLTC oil chamber shall have oil filling and drain plug, oil sampling valve, relief vent and level glass. It shall also be fitted with an oil surge relay the outlet to which shall be connected to separate conservator tank.
- o) The diverter switch or arcing switch shall be so designed as to ensure that its operation once commenced shall be completed independently of the control relays or switches, failure of auxiliary supplies etc. To meet any contingency which may result in incomplete operation of the diverter switch, adequate means shall be provided to safeguard the transformer and its ancillary equipment.
- p) Drive mechanism chamber shall be mounted on the tank in accessible position. It should be adequately ventilated and provided with anti condensation metal clad heaters. All contractors, relay coils and other parts shall be protected against corrosion, deterioration due to condensation, fungi etc.
- q) The control feature shall provide the following Equipment for local and remote electrical and local manual operation shall be provided and shall comply with the following conditions:
  - 1) Local-remote selector switch mounted in the local control cubicle (tap change driving unit) shall switch control of OLTC for lower/raise functions in local or remote mode as selected.
  - 2) The LOCAL-REMOTE selector switch shall have at least two spare contacts per position which are closed in that position but open in the other position.
  - 3) A RAISE-LOWER CONTROL SWITCH shall be provided in the Local Control Cubicle. The switch shall be spring loaded to return to the Centre 'OFF' position and shall require movement to the RIGHT to raise the voltage of the transformer. Movement to the left shall lower the voltage. Alternatively push button type arrangement of standard design may be provided. This switch shall be operative only when 'local remote', selector switch is in 'local' position.
  - 4) An OFF-ON tap changer control switch shall be provided in the OLTC local control cabinet for transformer. The tap changer shall be inoperative in the OFF position. Also the OFF-ON switch shall have at least one spare contact per position which is closed in that position but open in the other position.
  - 5) Operating mechanism for on load tap changer shall be designed to go through one step or tap change per command. Subsequent tap changes shall be initiated only by a new or repeat command.
  - 6) On load tap changer shall be equipped with a time delay in-complete STEP alarm consisting of a normally open contact which closes, if the tap changer fails to make a complete tap change. The alarm shall not operate for momentary loss of auxiliary power.
  - 7) The selsyn units or approved equivalents shall be installed in the local OLTC control cabinet to provide tap position indication for the transformer. Complete mounting details shall be included with approved diagram.
  - 8) Transformer load tap changer shall be equipped with a fixed resistor network capable of providing discrete voltage steps for input to the supervisory system.

**Technical Specification of 5 MVA and 10 MVA Power Transformer**

- 9) Limit switches shall be provided to prevent overrunning of the mechanism and in addition, a technical stop shall be provided to prevent over-running of the mechanism under any condition.
- 10) Limit switches may be connected in the control circuit of the operating motor provided that a mechanical-de-clutching mechanism is incorporated.
- 11) Thermal device or other means shall be provided to protect the motor and control circuit. All relays switches, fuses etc. shall be mounted in the drive mechanism chamber and shall be clearly marked for the purpose of identification. They shall withstand the vibrations associated with tap changer gear operation.
- 12) A permanently legible lubrication chart shall be fitted within the driving mechanism chamber.
- 13) Any 'DROP DOWN' tank associated with the tap changing apparatus shall be fitted with guide rod to control the movements during lifting or lowering.
- 14) The guide rods shall be so designed as to take support of the associated tank when in the fully lowered position with oil. Lifting gear fitted to 'DROP DOWN' tanks shall include suitable device to prevent run- away during lifting and lowering operations. They shall be provided with adequate breathing arrangement.
- 15) If specified the tap changer shall be mounted in such a way that the cover of the transformer can be lifted without removing connections between windings and tap changer.
- 16) A five digit counter shall be fitted to the tap changing equipment to indicate the number of operations completed. Suitable apparatus shall be provided for each transformer to give indications as follows. To give an indication at the remote control point that a tap change is in progress by means of an illuminated lamp.
- 17) All relays and operating devices shall operate correctly at any voltage between the limits specified.
- 18) It shall not be possible to operate the electric drive when the manual operating gear is in use. It shall not be possible for any two controls to be in operation at the same time.
- 19) The equipment shall be suitable for supervisory control and indication with make before break multi-way switch, having one potential free contact for each tap position. This switch shall be provided in addition to any other switch/switches which may be required for remote tap position
- 20) Operation from the local or remote control switch shall cause one tap movement only until the control switch is returned to the off position between successive operations.
- 21) All electrical control switches and the local operating gear shall be clearly labeled in a suitable manner to indicate the direction of tap changing.
- 22) Transfer of source failure of one AC supply shall not affect tap changing operation.
- 23) The equipment shall be so arranged as to ensure that when a tap change has been commenced it shall be completed independently of the operation of the

### **Technical Specification of 5 MVA and 10 MVA Power Transformer**

control relays or switches. If a failure of the auxiliary supply during a tap change or any other contingency such as tap changer getting stuck would result in that movement not being completed, adequate means shall be provided to safeguard the transformer and its auxiliary equipment. The tap changing switches and mechanism shall be mounted in oil tanks or compartments mounted in an accessible position on the transformer tank.

Any enclosed compartment not oil filled shall be adequately ventilated, metal clad thermostatically controlled heaters shall be provided in the driving mechanism chamber and in the marshalling box, all contactors, relay coils or other parts shall be suitably protected against corrosion or deterioration due to condensation, fungi, etc.

The tap changer contacts which are not used for making or breaking current like separate selector switch contacts can be located inside main transformer tank where tap changer construction permits such an arrangement. On load tap changers having separate compartment for selector contacts, the oil in such compartment shall be maintained under conservator had by means of pipe connection from the highest point of the chamber to the conservator. Such connection shall be controlled by suitable valve and shall be arranged so that any gas leaving the chamber will pass into the gas and oil actuated relay. A separate surge relay may be provided for this compartment.

It shall not be possible for the oil in these compartments of the tap change equipment, which contain contacts used for making or breaking current, to mix with the oil in the compartments containing contacts not used for making or braking current

#### **6.6.2 Manual Control :**

The cranking device for manual operation of the OLTC gear shall be removable and suitable for operation by a man standing on ground level.

**The mechanism shall be complete with the following:**

- 1) Mechanical tap position indicator which shall be clearly visible to the person operating tap changer manually at the transformer.
- 2) A mechanical operation counter.
- 3) Mechanical stops to prevent over-cranking of the mechanism beyond the extreme tap positions.
- 4) The manual control considered as back up to the motor operated load tap changer control shall be interlocked with the motor to block motor start-up during manual operation. The manual operating mechanism shall be labeled to show the direction of operation for raising the voltage and vice versa.

#### **6.6.3 Electrical Control :**

This includes the following:

- 1) Local Electrical control
- 2) Electrical remote control from remote control panel.

The control circuits shall have the following features:

### **Technical Specification of 5 MVA and 10 MVA Power Transformer**

- a) An interlock to cut off electrical control automatically upon recourse being taken to the manual control in emergency
- b) Reinforcement of the initiating impulse for a tap change, ensuring a positive completion once initiated to the next (higher or lower) tap.
- c) Step-by-step Operation ensuring only one tap change from each tap changing impulse and a lock-out of the mechanism if the control switch (or push button) remains in the "operate" position
- d) An interlock to cut-out electrical control when it tends to operate the gear beyond either of the extreme tap positions.
- e) An electrical interlock to cut-off a counter impulse for reverse step change being initiated during a progressing tap change and until the mechanism comes to rest and resets circuits for a fresh position.
- f) Tap change in progress by means of an indicating lamp at the remote panel. Necessary contacts for this and for remote tap position indicator at remote panel shall be provided by the Contractor.
- g) Protection apparatus, considered essential by the Contractor according to specialties.
- h) Remote Electrical Group Control.

The OLTC control scheme offered shall have provision of remote electrical group Control during parallel operation of transformers. This is in addition to independent control of OLTC.

- i) A four position selector switch having MASTER, Follower, Independent and OFF position shall be provided in the remote OLTC control panel for each transformer. This shall be wired to enable operator to select operation of OLTC in Master, Follower or Independent mode.
- ii) Out of step relays with timer contacts shall also be provided to give alarm and indication in case of tap positions in all the transformers under group control being not in same position. An out-of-step device shall be provided for each transformer which shall be arranged to prevent further tap changing when transformers in a group operating in 'Parallel control' are one tap out-of-step.
- iii) Master Position: -  
If the selector switch is in MASTER position, it shall be possible to control the OLTC units in the FOLLOWER mode by operating the controls of the MASTER unit Independent operation of the units under FOLLOWER mode shall have to be prevented. However, the units under independent mode will be controlled independently
- iv) Follower Position:  
If the selector switch is in FOLLOWER mode, control of OLTC shall be possible only from MASTER panel
- v) Independent Position: In this position of Selector Switch, Control of OLTC of individual unit only shall be possible.
- vi) An out of step device shall be provided for each transformer which shall be arranged prevent further tap changing when transformers in a group operating in parallel control are one tap out of step.

## Technical Specification of 5 MVA and 10 MVA Power Transformer

### 6.6.4 Tapping method :

- a) The switch position no.1 shall correspond to the maximum plus tap.
- b) The primary winding shall be connected delta and secondary winding star as per vector group Dyn 11 (IS 2026 latest version.) so as to produce a positive displacement of 30 deg. From the primary to the secondary vector of the same phase (vector rotation assumed counter clockwise).
- c) The neutral point of the secondary winding shall be solidly earthed and should be brought out to separate insulated terminal through an earthing current transformer for an earth leakage relay to be connected whenever required.

### 6.6.5 Local OLTC Control Cabinet :

The auxiliary devices for electrical control of the OLTC shall be housed in a weather proof cabinet. It shall be complete with the following:

- a) A circuit breaker / contactor with thermal overload devices for controlling the AC auxiliary supply to the OLTC motor.
- b) Cubicle light with door switch.
- c) Space heaters to prevent condensation of moisture
- d) Padlocking arrangement for hinged door of cabinet.
- e) Cable terminal glands for power and control cables to the OLTC gear.

### 6.6.6 Remote Tap Changer Control (RTCC) Panel :

- A) The auxiliary devices for remote electrical control of the OLTC and Cooler shall be housed in a separate panel to be placed in the Control room. The panel shall be made of sheet steel of thickness not less than **14 SWG** and it shall be duly finished with Stoved Enamel paint. The size and color of the control cubicle to be supplied by the supplier shall be **750 mm** depth and **2312 mm** height and Olive Green (shade no.220, IS : 5 ) respectively. The width of the cubicle may be as per the suppliers practice. The cabinet sealing system shall have a degree of protection not less than IP-42.

The Control and signal devices required to be mounted in the RTCC Panel shall comprise of the following :

- a) Relays in the control circuit for the operation of the transformers in parallel.
- b) Remote Tap position indicator.
- c) (i) Tap changer in progress.  
(ii) Tap changer out of step.
- d) Lamps (white) showing healthy auxiliary supply from 240/110 Volts Center point earthing transformer.
- e) Time delay contactors 1-5 Seconds with 5 Amps. Contacts for tripping when a follower fails to go into steps with the master together with indication.
- f) Oil temperature alarm with suitable cancellation device.
- g) Winding Temperature alarm with suitable cancellation device for 5 MVA & 10 MVA Transformer.
- h) Signaling apparatus for out-of-step alarm.
- i) Time delay contactors 1-5 Seconds for tripping due to incorrect coupling in.

**Technical Specification of 5 MVA and 10 MVA Power Transformer**

- j) Master position (out of step tripping). The desired time delay for tripping will be to 50 Seconds.
  - k) Remote Push Button for Lower & Raise Tap.
  - l) Alarm cancellation Push Button.
  - m) Tap Changer Supply Isolating Switch.
  - n) Sequence Selector Switch.
  - o) Out of Step Alarm with Cancellation Push Button.
  - p) Panel Strip Heater with Switch.
  - q) Panel Lamp with Door Switch.
  - r) Surge relay trip.
  - s) Upper limit & lower limit reached.
  - t) Two spare windows.
  - u) Buchholz relay alarm.
  - v) Buchholz relay trip.
  - w) Pressure relief device trip.
  - x) MOLG low oil level alarm.
- B) Terminal Block (for RTCC Panel and Cooler Control Cabinet) :**
- 1) **The terminal block shall be stud type.** The terminal blocks should be as per **IEC 60947/7-1. The insulating material should be polyamide and all the metal parts should be non ferrous.** The screws should be captive and terminal be shock protected. All terminals shall be clearly marked with identification numbers or letters to facilitate connection to external wiring.
  - 2) All internal wiring to be connected to the external equipment shall be terminated on terminal blocks, preferably **vertically mounted** on the side of each panel. The terminal blocks shall be **1100 V grade and have 10 amps continuous rating**, molded piece, complete with insulated barriers, **non-disconnecting stud type terminals**, washers, nuts and lock nuts. Terminal block design shall include a white fiber-marking strip with clear plastic, slip-on/clip-on terminal cover. Markings on the terminal strips shall correspond to wire number and terminal numbers on the wiring diagrams.
  - 3) Terminal blocks for current transformer secondary leads shall be provided with test links and isolating facilities. Also current transformer secondary leads shall be provided with short-circuiting and earthing facilities.
  - 4) At least 20% spare terminals shall be provided on each cubicle and these spare terminals shall be uniformly distributed on all terminal blocks.
  - 5) Unless otherwise specified, terminal blocks shall be suitable for connecting the following conductors on each side.
    - a) For all circuits except current transformer circuits: minimum of two nos. of 2.5 mm<sup>2</sup> copper.
    - b) For all CT circuits: minimum two nos. of 4 mm<sup>2</sup> copper.
  - 6) There shall be a minimum edge to edge clearance of 250 mm between the first row of terminal block and the associated cable gland plate. Also the clearance between two rows of terminal blocks shall be minimum 150 mm.

**Technical Specification of 5 MVA and 10 MVA Power Transformer**

- 7) Arrangement of the terminal block assemblies and the wiring channel within the enclosure shall be such that a row of terminal blocks is run parallel and in close proximity along each side of the wiring duct to provide for convenient attachment of internal panel wiring. The side of the terminal block opposite the wiring duct shall be reserved for the owner's external cable connection. All adjacent terminal blocks shall also share this field wiring corridor. A steel strip shall be connected between adjacent terminal block rows at 450 mm intervals for support of incoming cables.

**6.7 OLTC and Diverter chamber Conservator tank :-**

- a) Conservator should be volumetric capacity of at least 10 % of total volume of oil in the OLTC tank. Moreover the oil in conservator up to the minimum level mark on the oil level gauge should be at least 3 % of the total volume of oil in the OLTC. Conservator having a capacity between the highest and the lowest visible levels to meet the requirement of expansion of the total cold oil volume in the transformer and cooling equipment from the minimum ambient temperature i.e. -5 Deg. C to 98 Deg. C. Conservator for OLTC and Diverter chamber shall be single with partition inside and with clear visible indication for both OLTC and Diverter chamber.
- b) Flexible rubber bag (Air cell) should be provided inside of conservator tank for oil preservation system. Air cell material shall be special type of fabric coated with special grade nitrile rubber which outer surface is oil resistant and inner surface is ozone resistant. It shall be possible to remove or replace the Air cell if required.
- c) Conservator shall be bolted into position so that it can be removed for easy cleaning and other maintenance work. Main pipe from tank shall be projected about 20 mm above conservator bottom for creating a sump for collection of impurities. Conservator minimum oil level corresponding to minimum temperature shall be well above the sump level.
- d) Conservator shall be supported at minimum two points to OLTC tank.
- e) Conservator shall be mounted in such a way that the OLTC can be inspected / maintained without disturbing the conservator.
- f) Following fittings and accessories shall be provided on OLTC tank conservator:
- i) Prismatic oil gauge with three position Normal, Minimum and Maximum marking.
  - ii) End cover.
  - iii) Oil feeling hole with cap.
  - iv) Magnetic Oil gauge with LOW LEVEL alarm
  - v) Silica Gel Dehydrating Breather with oil seal and filter . Container and oil cup should be polycarbonate single piece clearly transparent cover and resistant to UV rays
  - vi) Drain cum filling valve (Gate valve with locking rod and position indicator, made of Brass 25 mm with cover plate.
  - vii) Shut off valve (Gate valve) with position indicator made of Brass 80 mm located before and after OLTC Buchholz relay.

## Technical Specification of 5 MVA and 10 MVA Power Transformer

- viii) Flange for Breather connection.
- ix) Air release valve on conservator made of Brass 25 mm with cover plate.
- g) Breather body should be Aluminum pressure die cast, shot blasted and powder coated. Container and oil cup should be 143R grade UV resistant polycarbonate. All gaskets should be of nitrile cork (RC 70C) rubber. Breather should be flanged type . Breather piping shall not any valve placed in between conservator and breather. Breather shall be removable type mounted at suitable height from ground level. Breather shall be tested for 0.35 kg / cm for all joints. Silica Gel used in breather should be 2.5 mm diameter ROUND BALL type and should be bio-degradable, non-carcinogenic.

### 7.0 Protection & Measuring Devices

#### i) Oil Conservator Tank

- a) The Conservator tank shall have adequate capacity between highest and lowest visible levels to meet the requirement of expansion of the total cold oil volume in the transformer and cooling equipment.
- b) The conservator tank shall be bolted into position so that it can be remove for cleaning purposes.
- c) The conservator shall be fitted with magnetic oil level gauge with low level electrically insulated alarm contact.
- d) Plain conservator fitted with silica gel breather.

#### ii) Pressure Relief Device.

The pressure relief device provided shall be of sufficient size for rapid release of any pressure that may be generated in the tank and which may result in damage of the equipment. The device shall operate at a static pressure of less than the hydraulic test pressure of transformer tank. It shall be mounted direct on the tank. A pair of electrically insulated contract shall be provided for alarm and tripping

#### iii) Buchholz Relay

A double float type Buchholz relay shall be provided. Any gas evolved in the transformer shall collect in this relay. The relay shall be provided with a test cock suitable for a flexible pipe connection for checking its operation. A copper tube shall be connected from the gas collector to a valve located about 1200 mm above ground level to facilitate sampling with the transformer in service. The device shall be provided with two electrically independent potential free contracts, one for alarm on gas accumulation and the other for tripping on sudden rise of pressure.

#### iv) Temperature Indicator

##### a) Oil Temperature Indicator (OTI)

The transformers shall be provided with a micro switch contact type thermometer with 150 mm dial for top oil temperature indication. The thermometer shall have adjustable, electrically independent potential free alarm and trip contacts. Maximum reading pointer and resetting device shall be mounted in the local control panel. A temperature sensing element suitably located in a pocket on top oil shall be furnished. This shall be connected to the OTI by means



## Technical Specification of 5 MVA and 10 MVA Power Transformer

of capillary tubing. Accuracy class of OTI shall be  $\pm 1\%$  or better. One No electrical contact capable of operating at 5 A ac at 230 volt supply.

### b) Winding Temperature indicator (WTI)

A device for measuring the hot spot temperature of the winding shall be provided. It shall comprise the following.

- i) Temperature sensing element.
- ii) Image Coil.
- iii) Micro switch contacts.
- iv) Auxiliary CTS, If required to match the image coil, shall be furnished and mounted in the local control panel.
- v) 150mm dial local indicating instrument with maximum reading pointer mounted in local panel and with adjustable electrically independent ungrounded contacts, besides that required for control of cooling equipment, one for high winding temperature alarm and one for trip.
- vi) Two number electrical contact each capable of operating at 5 A ac at 230 Volt supply.

### 8.0 Oil :

#### A) Insulation Oil :

As per annexure – I attached.

The quantity of transformer oil excluding OLTC shall not be less than **3000** Ltrs for 5 MVA And **4500** Ltrs for 10 MVA Transformer. One sample of oil drawn from every lot of Power Transformer offered for inspection should be tested at NABL accredited lab for tests as listed under Table-1 of IS : 1866(2000). The cost of this testing should be included within the cost of the cost of Power Transformer.

### 9 Oil Preservation Equipment: Oil Sealing

The oil preservation shall be diaphragm type oil sealing in conservator to prevent oxidation and contamination of oil due to contact with atmospheric moisture.

The conservator shall be fitted with a dehydrating filter breather. It shall be so designed that.

- i) Passage of air is through a dust filter & Silica gel.
- ii) Silica gel is isolate from atmosphere by an oil seal.
- iii) Moisture absorption indicated by a change in colour of the crystals of the silica gel can be easily
- iv) Breather is mounted not more than 1400 mm above rail top level.

### 10.0 Bushing Insulators and Terminals:-

A) **Outdoor Type** : For outdoor type transformer vertically mounted porcelain bushing Insulators on top the transformer tank. The Main winding and Neutral leads shall be brought out through outdoor type of Bushings.

- i) Porcelain bushings shall be homogeneous, non-porous, uniformly glazed to brown colour and free from blisters, burns and other defects.
- ii) Stress due to expansion and contraction in any part of the bushing shall not lead to deterioration.
- iii) Bushing shall be designed and tested to comply with the applicable standards.

### Technical Specification of 5 MVA and 10 MVA Power Transformer

- iv) Bushing shall have non-ferrous flanges and hardware.
- v) Fittings made of steel or malleable iron shall be galvanized
- vi) Bushing shall be so located on the top of transformers that full flashover strength will be utilized.
- vii) Bushing shall be supplied with bi-metallic terminal connector/ clamp/ washers suitable for fixing to bushing terminal. and the Employers specified conductors.  
The connector/clamp shall be rated to carry the bushing rated current without exceeding a temperature rise of 55°C over an ambient of 50°C. The connector/clamp shall be designed to be corona free at the maximum rated line to ground voltage.
- viii) Bushing of identical voltage rating shall be interchangeable.
- ix) The insulation class of high voltage neutral bushing shall be properly coordinated with the insulation class of the neutral of the low voltage winding.
- x) Each bushing shall be so coordinated with the transformer insulation that all flashover will occur outside the tank.

#### B) Indoor Type

- i) The extended bushing bus bars shall be used for termination of HV & LV cables. HV & LV busing shall be housed in completely sealed metallic enclosure. The shape of the HV & LV cable box should be rectangular type. No radiator fins arrangement below the HV & LV cable boxes for smooth handling and connections of cables.
- ii) M.S sheet, weather, vermin and dust proof cable box, with minimum 3 mm thickness fitted with required glands, of a suitable construction shall be provided with each transformer to accommodate HV and LV cables. The box shall have slopping roof. The interior white and exterior olive green paint shall be in accordance with the specification. The degree of protection shall be IP-55 or better. All incoming cables shall enter the cable box from the bottom and the minimum 4mm thick, non-magnetic, gland plate shall not be less than 600mm from the base of the box. The gland plate and associated compartment shall be sealed in suitable manner to prevent the ingress of moisture from the cable trench – for those transformers which are used in partly indoor substation,
- iii) HV and LV cable boxes should be on opposite side. The clearances, dimensional, technical details for HV and LV cable boxes should be as per CBIP -317-2017.
- iv) LV side cable box suitable for 11 KV should be 1C or 3C x 300 sq. mm, 1 run for 5 MVA and 2 runs for 10 MVA)
- v) HV side cable size suitable for 33 kV should be 1C or 3 C x 240 sq. mm, 1 run for 5 MVA & 1 run for 10 MVA) and for 22 KV side 1C or 3C X 240 sqmm. for 5 MVA and 1C or 3C X 300 sqmm for 10 MVA)
- vi) LV Neutral shall be brought out at top cover & connect with 2 nos of 75 x 10 mm insulated sleeve up to bottom of the tank through proper insulation support.

#### C) Bushing Technical Parameters for Outdoor/Indoor Power Transformer :

- a) 36kV bushing: 630 Amp.
- b) 12kV bushing: 1000Amp.
- c) Dry and Wet power frequency withstand test for 1 minute

### Technical Specification of 5 MVA and 10 MVA Power Transformer

- i) For 33kV bushing : 50KV for 1 min.
- ii) For 11 kV busing : 28KV for 1 min.
- d) Angle of mounting: 90 deg.
- e) Cantilever withstand load : for 33kV & 11 KV bushing – as per standard
- f) Minimum creepage distance: 25 mm / kV.
- g) Protected creepage distance : At least 50% of total creepage distance.
- i) Continuous current rating : Minimum 20% higher than the current corresponding to the minimum tap of the Power Transformer.
- h) Atmospheric protection for clamp and fitting of iron and steel : Hot dip galvanizing as per IS : 2633.
- i) Bushing terminal lugs in oil and air : Tinned copper.
- j) Sealing washer / Gasket ring : RC 70 C Nitrile cork / Nitrile Rubber.

#### 11.0 Marshalling Box Cubicle :

- i) Sheet steel, weather, vermin and dust proof marshaling box fitted with required glands, locks, glass door, terminal Board, heater with switch, illumination lamp with switch, water-tight hinged and padlocked door of a suitable construction shall be provided with each transformer to accommodate temperature indicators, terminal blocks etc. The box shall have slopping roof and the interior and exterior painting shall be in accordance with the specification. Padlock along with duplicate keys shall be supplied for marshaling box. The degree of protection shall be IP-55 or better.
- ii) The schematic diagram of the circuitry inside the marshaling box be prepared and fixed inside the door under a propone sheet.
- iii) The marshaling box shall accommodate the following equipment
  - a) Temperature indicators.
    - i) Winding Temperature Indicator
    - ii) Oil Temperature Indicator.
  - b) Terminal blocks and gland plates for incoming and outgoing cables.

All the above equipment except c) shall be mounted on panels and back of panel wiring shall be used for inter-connection. The temperature indicators shall be so mounted that the dials are not more than 1600 mm from the ground level and the door (s) of the compartment(s) shall be provided with glazed window of adequate size. The transformer shall be erected on a plinth which shall be 2.5 feet above ground level.
  - iv) To prevent internal condensation, a metal clad heater with thermostat shall be provided. The heater shall be controlled by a MCB of suitable rating mounted in the box. The ventilation louvers, suitably padded with felt, shall also be provided. The louvers shall be provided with suitable felt pads to prevent ingress of dust.
  - iv) All incoming cables shall enter the kiosk from the bottom and the gland plate shall not be less than 450 mm from the base of the box. The gland plate and associated compartment shall be sealed in suitable manner to prevent the ingress of moisture from the cable trench.
    - 1) Material for construction of marshalling box : Construction of marshalling box should be stainless steel more than 316 grade with powder coating of 1.6mm with specified color shed.

### **Technical Specification of 5 MVA and 10 MVA Power Transformer**

- 2) Door hinges of marshalling box should be from inner side and should not be exposed to rain. Gland plate mounting should be from inside only.  
Digital temperature scanner. TB with LED for all TRIP & ALARM signals.
- 3) Major equipment required for marshalling box :
  - a) One digital scanner for ( OTI alarm, WTI alarm Fan ON + 4-20mA for OTI & WTI).
  - b) Dial type Gauge with alarm & TRIP contacts for LV WTI.
  - c) Other panel accessories as listed as listed in spec.
- 4) Gland plate Min.3mm thick detachable with knockout 6X1 inch.
- 5) Contact wired terminal block connect well TTB with LED shall be used for all TRIP & alarm terminals (TTB No. DDFL4ULR) TTB shall be of “Solid Link” type & TTB with “Glass fuse “ type will not be acceptable. POLYAMIDE Minimum 8 mm width 2nos DDFL4ULR with brass link & end plate for each alarm and tripping ( One spare for each).Disconnecting type for WTI CT stud type with screwdriver operated for others separated terminal blocks for protection and Fan control are essential.
  - a) WTI alarm and TRIP.
  - b) OTI alarm and Trip.
  - c) Buchholz relay alarm and trip.
  - d) OSR trip contacts
  - e) MOG low level alarm.
  - f) MOG on OLTC low level alarm.
  - g) PRV main tank trip.
  - h) PRV OLTC trip.
  - i) WTI and OTI relay contacts of the temperature scanner.
  - j) Contacts in addition to above as required by customer during drawing approvals. To be provided by supplier.
- 6) Signals to be wired to terminal block :
  - a) WTI CT.
  - b) NCT.
  - c) Sensor for temperature scanner.
  - d) Capillaries for WTI and OTI.
- 7) IP55 Ingress protection plus additional rain canopy to be provided. Continuous welding on joints, welding at regular intervals on joints and filling of gaps with use of M seal not accepted. Cable entry from bottom for all cables. Panel internal access from front only through front door double leaf with antitheft hinges. Panel back access not accepted. Separate mounting for marshalling box. Panel supply 240V AC, Single Phase, 50Hz.

**Technical Specification of 5 MVA and 10 MVA Power Transformer**

- 8) Panel accessories :
  - a) Cubicle lamp with door switch and separate fuse/MCB.
  - b) Approved space heaters controlled by thermostat and separate fuse /MCB
  - c) Incoming fuse switch/MCB for the incoming supply.
  - d) Panel wiring diagram fixed on back of panel door on aluminum plate engraved fixed by rivet.
  - e) Stainless steel door handle with lock & additional facility for padlock.
  - f) Single phase power plug industrial type 15/5Amp. With MCB.
  - g) TTB for all trip commands.
- 9) Fan motor control if installed in marshalling box or separate fan control cubicle. Fan shall have wire guard on both the sides.
  - a) 2X50% fans.
  - b) Complete fan control with fuse switch, contactor, Bimetallic relay, in starter circuit with type 2 coordinated rating as per IS.
  - c) Automatic control from WTI contact.
  - d) Provision for manual controls both from local/remote.
  - e) Fan control cubicle should be separately mounted.
  - f) 2RC/2RS type bearings shall be used instead of ball bearings.
  - g) Fan enclosure shall have perforated sheet with holes at motor side.
  - h) Fan shall have wire guard on both sides.
  - i) Fan support enclosure shall be ground mounted & not take any support from transformer radiators.
- 10) Fan control shall be Scanner operated auto manual scheme required single contactor for common control. MPCB shall be suitable rating range for each fan with auxiliary contact. Fan identification numbers on both at MPCB and fan end. Standby fan logic in a day, standby fan shall run for 15minutes.
- 11) Wires & Cables (FRLSH) :
  - a) AC control wiring- 1.5sq.mm black.
  - b) Screened cable for PT100 sensor.
- 12) Illumination & Socket Shall be of LED type with 5/15A domestic socket with MCB for control & protection.
- 13) Hardware : M 16 size & below stainless steel and above M 16 Hot dip galvanized steel hardware shall be used for external purpose. Cadmium plated except special hardware frame parts and core assembly as per manufacturer's design hardware shall be used for internal purpose.
- 14) All oil Surge relays, Buchholz And Pressure release valve shall be fully Enclosed With Aluminum hoods / Canopy for protection against water ingress.
- 15) Gasket : RC 70 c Nitrile Cork / NBR 70 C shall be used for Transformer, OLTC chamber, PT chamber, surfaces interfacing with oil inspection cover etc. and also for Cable boxes, Marshaling box, OLTC drive mechanism etc.

## **Technical Specification of 5 MVA and 10 MVA Power Transformer**

### **12) Valves :**

- a) Material : Brass.
- b) Type : Both end flanged gate valve / butterfly valve depending on application.
- c) Size : As per manufacture standard.
- d) Position indicator, locking rod, padlocking facility, valve guard and cover late shall be provided to valves.

### **13) Control Cable routing on Power Transformer:**

Control cables for accessories on transformer tank to Marshalling box & WTI, OTI capillaries shall be routed through perforated Covered GI Trays.

Control cable shall be PVC insulated, extruded PVC inner sheathed, armoured, extruded PVC outer sheathed FRLS 1100 V grade control cable as per latest edition of IS 1554 part 1 minimum 2.5 sq mm for signals and 4 sq mm for CT with multistrand copper conductor.

The wires to be used inside marshalling box and OLTC drive mechanism Box shall be PVC insulated multistrand flexible copper wires of minimum 2.5 sqmm size, 1100 V grade FRLSH as per latest edition of relevant IS.

Cable routing from Transformer to Marshalling box should be done in such a way that adequate protection is available from mechanical and fire damage.

### **14 RADIO INTERFERENCE AND NOISE LEVEL**

Transformers shall be designed with particular care to suppress at least the third and fifth harmonic voltages so as to minimize interference with communication circuits. Transformer noise level when energized at normal voltage and frequency shall be as per NEMA stipulations.

### **15 Painting of transformer, Conservator, OLTC, Radiator, Marshalling box:**

- a) Surface preparation shall be done by 7 tank pretreatment process or shot blasting method.
- b) Finish on internal surfaces of the transformer interfacing with oil shall be painted with bright yellow heat resistant and oil resistant paint two coats. Paint shall neither react nor dissolve in hot transformer insulating oil.
- c) Frame parts shall be painted with bright Yellow heat resistant and oil resistant paint two coats. Paint shall neither react nor dissolve in hot transformer insulating oil.
- d) Finish on inner surface of the Marshalling box shall be done with white Polyurethane paint anti-condensation type two coats, minimum dry film thickness. 80 microns.

### **Technical Specification of 5 MVA and 10 MVA Power Transformer**

- e) Finish on outer surface of the transformer, conservator, radiator, cable boxes, marshalling box shall be **Olive Green (shade no.220, IS : 5 )** with one coat of primer & two coats of Polyurethane paint, minimum dry film thickness 120 microns paint.

#### **16.0 Minimum Protective devices on Power Transformer :**

- 1) Spring loaded with detachable diaphragm type Pressure Relief Valve ( PRV) with two trip contacts for Main Tank of LSM model with limit switch design, IP : 65 with rain hood.
- 2) Spring loaded with detachable diaphragm type Pressure Relief Valve ( PRV) with two trip contacts for OLTC of LSM model with limit switch design, IP : 65 with rain hood.
- 3) Double Float Buchholz alarm Relay with alarm and trip contacts, service and test position with cock for the Main Tank. Terminal box shall be IP : 65 with drain plug for water draining. Additional rain hood shall be provided.
- 4) Oil Surge Relay with alarm and trip contacts, service and test position with cock for the OLTC. Terminal box shall be IP : 65 with drain plug for water draining. Additional rain hood shall be provided.

Oil temperature indicator metallic bulb type 150 mm diameter with maximum reading pointer, potential free independent adjustable alarm and trip contacts, resetting device with temperature sensing element.

- 5) Winding temperature indicator 150 mm diameter with maximum reading pointer, two sets of potential free independent adjustable alarm and trip contacts, resetting device with temperature sensing element, thermal image coil.
- 6) 2 Nos. Pt 100 sensors / RTDs for winding temperature indication wired up to TBs in marshalling box for external connection.

#### **17.0 Nitrogen injection Fire Protection System (NIFPS) ;**

The Nitrogen injection Fire Protection System (NIFPS) is for 10 MVA Power Transformer Nitrogen injection Fire Protection System (NIFPS) shall use nitrogen as fire quenching medium. The protective system shall prevent Transformer/Reactor's oil tank explosion and possible fire in case of internal faults. In the event of fire by external causes such as bushing fire, OLTC fires, fire from surrounding equipments etc, it shall act as fast and effective fire fighter. It shall accomplish its role as fire preventer and extinguisher without employing water and/or carbon dioxide. Fire shall be extinguished within 3 minutes (Maximum) of system activation and within 3 seconds (Maximum) of commencement of nitrogen injection.

Detailed technical specification of **NIFPS is as per Anx. II.**

## Technical Specification of 5 MVA and 10 MVA Power Transformer

### 18.0 Fittings and Accessories on Power Transformer:

The following fittings and accessories shall be provided on the transformers:

- i) Conservator with isolating valves, oil filling hole with cap and drain valve. The conservator vessel shall be filled with constant oil pressure diaphragm oil sealing system.
- ii) Magnetic type oil level gauge (150 mm diameter) with low oil level alarm contacts.
- iii) Prismatic/ toughened glass oil level gauge.
- iv) Silica gel breather with oil seal and connecting pipe complete with first fill of activated silica gel or Alumina mounted at a level of 1300 mm above ground level.
- v) A double float type Buchholz relay with isolating valve. Bleeding pipe and a testing cock, the test cock shall be suitable for a flexible (pipe connection for checking its operation). A 5mm dia. Copper pipe shall be connected from the relay test cock to a valve located at a suitable height above ground level to facilitate sampling of gas with the transformer in service. Interconnection between gas collection box and relay shall also be provided. The device shall be provided with two electrically independent ungrounded contacts, one for alarm on gas accumulation and the other for tripping on sudden oil surge. These contacts shall be wired upto transformer marshaling box. The relay shall be provided with shut off valve on the conservator side as well as on the tank side.

The oil connection from transformer tank to the Conservator Vessel shall be arranged at a rising angle of 3 to 9° to the horizontal up to the Buchholz Relay and shall consist of 50 mm. inside diameter pipe as per latest IS 3639 or equivalent International Standard.

- vi) Pressure relief devices (including pressure relief valve) and necessary air equalizer connection between this and the conservator with necessary alarm and trip contacts.
- vii) Air release plugs in the top cover.
- viii) Inspection cover, access holes with bolted covers for access to inner ends of bushing etc.
- iv) Winding temperature (hot spot) indicating device for local mounting complete in all respects. Winding temperature indicator shall have two set of contacts to operate at different settings:
  - a) To provide winding temperature high alarm
  - b) To provide temperature too high trip
- v) Dial thermometer with pocket for oil temperature indicator with one set of alarm and one set of trip contacts and maximum reading pointer.
- vi) Lifting eyes or lugs for the top cover, core and coils and for the complete transformer.
- vii) Jacking pads
- viii) Haulage lugs.
  - ix) Protected type mercury / alcohol in glass thermometer and a pocket to house the same.
  - x) Top and bottom filter valves on diagonally opposite ends with pad locking arrangement on both valves.
  - xi) Top and bottom sampling valves.
- xii) Drain valve with pad locking arrangement
- xiii) Rating and connection diagram plate.
- xiv) Two numbers tank earthing terminals with associated nuts and bolts for connections to Employer's grounding strip.



### **Technical Specification of 5 MVA and 10 MVA Power Transformer**

- xv) Marshaling Box (MB)
- xvi) Shut off valve on both sides of flexible pipe connections between radiator bank and transformer tank
- xvii) Cooling Accessories:
  - a) Requisite number of radiators provided with :-
    - One shut off valve on top
    - One shut off valve at bottom
    - Air release device on top
    - Drain and sampling device at bottom
    - Lifting lugs.
  - b) Air release device and oil drain plug on oil pipe connectors.
- xviii) Terminal marking plates for Current Transformer and Main Transformer
- xviii) On/Off Load Tap changer as specified in BOQ
- xvii) Oil Preservation Equipment
- xvi) Oil Temperature indicator

#### **19.0 Tests :**

##### **A) Type Tests:**

- 1) The transformer offered should have been successfully type tested at NABL laboratories, in line with standard and technical specifications, within the last 5 (five) years from the date of opening of Tender. The tenderer shall furnish the following type tests reports (alongwith General arrangement drawing, Rating and Diagram Plate and Internal Constructional drawing, Core & Core details with flux density calculations) alongwith the offer.
  - i) Impulse Voltage withstand Test chopped on the tail on all three LV & HV phases.
  - ii) Temperature Rise Test on Tap No. 17 ( i.e. –15% voltage Tap)
  - iii) Short circuit Test
  - iv) Noise level measurement.
- 2) The type test reports should be submitted and got approved from the Chief Engineer (Testing & QC) before commencement of supply.
- 3) In case of any of the following, the offer may be considered for placement of order.
  - i. If above tests are carried out beyond 5 years
  - ii. Impulse Voltage Withstand test, Short Circuit test, Temperature Rise Test carried and Noise level measurement out not from NABL approved Laboratory.
  - iii. If there is any change in the design/ type of old type tested transformers to be offered against this specification.
- 4) In respect of the successful bidder, the purchaser reserves the right to demand repetition of some or all the type tests in presence of the purchaser's representative. In case the unit fails in the type tests, the complete supply shall be rejected. The

### **Technical Specification of 5 MVA and 10 MVA Power Transformer**

bidders are therefore requested to quote unit rates for carrying out each type test, which however, will not be considered for evaluation of the offer.

- 5) However, successful bidders have to carry out the type tests at the laboratories accredited by NABL before commencement of supply at their own expense on the sample drawn by the purchaser from the lot offered for first Stage Inspection.
- 6) If above tests are carried out beyond 5 years, then the offer may be considered for placement of order however, successful bidders have to carry out the said type tests before commencement of supply at their own expense.
- 7) If above tests are carried out on higher capacity of offered type transformer, then the offer is considered for placement of order. However, successful bidders have to carry out the said type tests on offered type transformers before commencement of supply at their own expense.
- 8) The bidder should not make any changes or alteration in the transformer design / type offered against the subject tender.
- 9) If there is any change in the design/ type of old type tested transformers offered against the subject tender, the purchaser reserves right to demand of repetition of the type tests on the transformer to be supplied against subject tender, without any extra cost. The type test reports of the same should got approved from Chief Engineer (Testing & QC).
- 10) After getting drawings approval of power transformer to be supplied against subject tender, successful bidders should got approved of type test reports from office of the Chief Engineer (Testing & QC), 5<sup>th</sup> Floor, Prakashgad, MSEDCL, Bandra. The original type test reports should be made available for verification.

#### **B. Routine Tests:**

All transformers shall be subjected to the following routine tests at the manufacturers works.

The tests are to be carried out in accordance with the details specified in IS 2026.

- 1) Measurement of winding resistance.
- 2) Ratio, polarity and phase relationship.
- 3) Impedance voltage.
- 4) Load losses.
- 5) No-load losses and No-load current.
- 6) Insulation resistance.
- 7) Measurement of Harmonic level on No Load current.
- 8) Induced over voltage withstand.
- 9) Separate source voltages withstand.
- 10) Duty cycle of On-load Tap Changer.

**Technical Specification of 5 MVA and 10 MVA Power Transformer**

11) Oil leakage gas collection, oil surge and voltage tests on gas and oil actuated relays.

Following additional routine tests shall also be carried out on each transformer free of cost and the cost for these tests is deemed to have been included in the price quoted.

- a) Magnetic Circuit Test
- b) After assembly, each core shall be tested for 1 minute at 2000 Volts between all bolts, side plates, and structural steel work.
- c) Measurement of capacitance and tan delta to determine capacitance between winding & earth. This measurement shall be carried out before and after series of dielectric tests.
- d) Pressure Relief Device Test: The pressure relief device of each size shall be subjected to increasing oil pressure. It shall operate before reaching the test pressure specified in 'Tank Tests'. The device shall be sealed off after the excess pressure has been relieved. High voltage withstand test shall be performed on auxiliary equipment and wiring after complete assembly.

**A) Vacuum Test :**

The tank of a Power Transformer (excluding tap changing compartment, radiators and coolers) shall be able to withstand a vacuum gauge pressure of 68.0 KN/sq.m. (500 mm. of Hg).

The permanent deflection of the flat plate after subjecting the transformer tank to the above vacuum for one hour shall not exceed the following values, without affecting the performance of the transformer.

<b>Horizontal length of flat plate</b>	<b>Permanent deflection(mm)</b>
Up to and including 750 mm	5.0
751 to 1250	6.5
1251 to 2000	8.5
2001 to 2250	11.0
2251 to 2500	12.5
2501 to 3000	16
Above 3000	19

**B) Oil leakage Test :**

The tank and oil filled compartments shall be tested for oil tightness completely filled with air or oil of viscosity not greater than that of insulating oil conforming to IS : 335 at the ambient temperature and applying a pressure equal to the normal pressure plus 35 KN/ m<sup>2</sup> measured at the base of the tank. The pressure shall be maintained for a period of not less than 12 hours of oil and one hour for air and during that time no leak shall occur.

## **Technical Specification of 5 MVA and 10 MVA Power Transformer**

### **C) Pressure Test :**

Where required by the Employer, one transformer tank of each size together with its radiator, conservator vessel and other fittings shall be subjected to a pressure corresponding to twice the normal head of oil or to the normal pressure plus 35 KN / m<sup>2</sup> whichever is lower, measured at the base of the tank and maintained for one hour.

### **D) Inspection of Insulation oil :**

To ascertain the quality of the transformer oil, the original manufacturer's test report should be submitted at the time of inspection. Also arrangements should be made for testing of transformer oil, after taking out the sample from the manufactured transformer and tested in the presence of MSEDCL representative or in an independent laboratory.

## **20.0 Rejection :**

Apart from rejection due to failure of the transformer to meet the specified test requirements the transformer shall be liable for rejection on any one of the following reasons.

- i No load loss exceeds the values mentioned in Clause. No. 6.10 above.
- ii Load loss exceeds the specified values mentioned in Clause No. 6.10 above.
- iii Impedance voltage value exceeds the Guaranteed value plus tolerances as mentioned at clause No.6.8 above.
- iv Type test are not carried out as per clause no. 12, (A) of the specification.
- v Drawings are not submitted as per clause no. 16 of the specification.
- vi GTP not submitted as per clause no.20 of the specification.

## **21.0 Quality Assurance:**

### **1) Quality Assurance Program:**

Quality Assurance Program shall be submitted before contract award. Quality Assurance Program shall contain following :

- a) The structure of the organization.
- b) The duties and responsibilities assigned to staff ensuring quality of work.
- c) The system for purchasing, taking delivery and verification of material.
- d) The system for ensuring quality of workmanship.
- e) The system for control of documentation.
- f) The system for the retention of records.
- g) The arrangements for the Supplier are internal auditing.
- h) The tenderer shall submit the List of testing equipment available with them for testing the transformers for acceptance and routine tests as specified in the relevant standards and the present specification.

## **Technical Specification of 5 MVA and 10 MVA Power Transformer**

### **2) Quality Plan :**

Quality Plan shall be submitted by the successful bidder for approval of Chief Engineer (Testing & Q.C).

Quality Plan shall contain following as a minimum:

- a) An outline of the proposed work and program sequence.
- b) The structure of the Supplier's organization for the contract.
- c) The duties and responsibilities assigned to staff ensuring quality of work for contract.
- d) Hold and notification points.
- e) Submission of engineering documents required by specification.
- f) The inspection of material and components on receipt.
- g) Reference to the Supplier's work procedures appropriate to each activity.
- h) Inspection during fabrication and construction.
- i) Final inspection and test.
- j) Successful bidder shall submit Mills invoice, Bill of lading, Mill's test certificate for grade, physical tests, dimension and specific loss per kg for the core material to the Purchaser for verification in the quality plan suitably.
- k) Successful bidder shall submit outline of production, inspection, testing, packing, and dispatch documentation program.
- l) Successful bidder shall submit Copper / Aluminum conductor, Transformer oil, Core, Insulation, Porcelain bushing and Steel plate etc. materials test certificate.

### **22.0 Detail Progress Report:**

Detail Progress Report shall be submitted to Purchaser once in a month. Contains in Progress Report as below:

- a) Progress on Material procurement.
- b) Progress on fabrication.
- c) Progress on assembly.
- d) Progress on internal stage inspection.
- e) Reason for any delay in total program.
- f) Details of test failures if any in manufacturing stages.
- g) Progress on final box up.
- h) Constraints.
- i) Forward path.

### **23.0 Drawing Approval:**

The successful Bidders shall submit complete set of Drawings as as below in triplicate indicating dimensions to CE ( Testing & QC cell) for approval and get approved it before offering I st stage inspection. The drawings shall be of A-3 (420 x 297 mm) size only.

The bidder should not change design once offered as per A/T, Approved drawings and Type Test Reports.

- 1) Name plate drawing with terminal marking and connection diagram.
- 2) General Arrangement Drawing.

### **Technical Specification of 5 MVA and 10 MVA Power Transformer**

- 3) Internal Construction drawing.
- 4) Core & Core Details with flux density calculations.
- 5) Plug in HV Bushings assembly drawings and connector.
- 6) HV Bushings with creepage distance drawings.
- 7) LV Bushings assembly drawings.
- 8) LV Bushings with creepage distance drawings.
- 9) HV/LV cable box drawing.
- 10) Breather.
- 11) Foundation Plan.
- 12) Valve Schedule Drawing.
- 13) General Arrangement of Radiator.
- 14) General Arrangement of Marshalling Box with connection diagram with Fan Control Cubicle
- 15) Schematic diagram of Marshalling Box and Fan Control Cubicle.
- 16) Name plate drawing of OLTC.
- 17) Detail Arrangement of Tap Changer.
- 18) Breather of OLTC.
- 19) Tap Changer Phase Design.
- 20) Group Control of Tap Change Gear.
- 21) General Arrangement Drawing of Tap Changer Control.
- 22) General Arrangement Drawing of Nitrogen Injection Fire Protection System.
- 23) Schematic diagram of Nitrogen Injection Fire Protection System.
- 24) General Arrangement Drawing of RTCC Panel.
- 25) Bill of Material.
- 26) Packing List.
- 27) Quality Action Plan.

#### **24.0 Stage Inspection:**

- 1) The inspection may be carried out by the purchaser at any stage of manufacture. The successful tenderer shall grant free access to the purchaser's representatives at a reasonable time when the work is in progress. Inspection and acceptance of any equipment under this specification by the purchaser shall not relieve the supplier of his obligation of furnishing equipment in accordance with the specifications and shall not prevent subsequent rejection if the equipment is found to be defective.
- 2) Supplier shall give 10 days' advance intimation to the CE (Testing) and **SE(MM)** to organize stage inspection, Chief Engineer (Testing) will depute representatives from testing and inspection wing for the stage inspection.

#### **Inspection and Testing during manufacture as below:**

##### **a) Tank and Conservator :**

- i. Check correct dimensions.
- ii. Leakage Test of conservator as per CBIP manual .
- iii. Leakage Test on all tanks at normal head of oil plus 35 kN / sq. meter at the base of the tank for 24 hrs.
- iv. Vacuum and Pressure test on tank as per CBIP.
- v. Leakage test of radiators as per CBIP.

**Technical Specification of 5 MVA and 10 MVA Power Transformer**

- b) Core :**
- i. Vendor shall submit the documentary evidence for procurement of CRGO laminations and prove that they have procured / used new core material.
  - ii. During in process inspection at lamination sub vendor, MSEDCL representative shall randomly select / seal lamination for Testing at ERDA / CPRI ( Accredited NABL labs ) for specific core loss, accelerated ageing test, surface insulation resistivity, AC permeability and magnetization, stacking factor, ductility etc. This testing shall be in the scope of Vendor.
  - iii. Check amount of burrs.
  - iv. Bow check on stamping.
    - v. Check for the overlapping of stampings. Corners of the sheet are to be apart.
  - vi. Visual and dimensional check during assembly stage.
  - vii. High voltage test ( 2kV for one minute) between core and clamps.
- c) Insulating Materials :**
- i. Sample check for physical properties of materials.
  - ii. Check of dielectric strength.
  - iii. Visual and dimensional checks.
  - iv. Check for the reaction of hot oil on insulating materials.
  - v. Certification of all test result
- d) Windings :**
- i. Sample check on winding conductor for mechanical properties and electrical conductivity.
  - ii. Visual and dimensional check on conductor for scratches, departmental mark etc.
  - iii. Sample check on insulating paper for PE value, Bursting strength, Electrical strength.
  - iv. Check for the reaction of hot oil on insulating paper.
  - v. Check for the bending of the insulating paper on conductor.
  - vi. Check and ensure that physical condition of all materials taken for winding is satisfactory and free of dust.
  - vii. Check for absence of short circuit between parallel strands.
  - viii. Check for Brazed joints wherever applicable.
  - ix. Measurement of voltage ratio to be carried out when core / yoke is completely restocked and all connections are ready.
  - x. Certification of all test results of winding / material.
- e) Check before drying process :**
- i. Check conditions of insulation on the conductor and insulation between windings.
  - ii. Check insulation distance between high voltage connection and earthed and other live parts.
  - iii. Check insulation distance between low voltage connection and earthed and other live parts.
  - iv. Insulation test of core earthing.
  - v. Check for proper cleanliness.

### **Technical Specification of 5 MVA and 10 MVA Power Transformer**

- vi. Check tightness of coil i.e. no free movement.
- vii. Certification of all test results.
- f) Check during drying process :**
  - i. Measurement and recording of temperature and drying time during vacuum treatment.
  - ii. Check for completeness of drying.
  - iii. Certification of all test results.
- g) Tests on fitting and accessories :**

As per manufacture's standard.
- h) Routine / Acceptance tests :**

The sequence of routine testing shall be as follows:

  - i. Visual and dimension check for completely assembled power transformer.
  - ii. Measurement of voltage ratio.
  - iii. Measurement of winding resistance at principle tap and two extreme taps.
  - iv. Vector group and polarity tests.

#### **26.0 Final Inspection:**

C.E. (MMD) will depute his representative ( IW representative) at the time of final inspection along with Testing Wing representative.

#### **27.0 Challenge Testing:**

The manufacturer can also request challenge testing for any test based on specification and losses. The challenger would request for testing with depositing testing fees, transportation 'To and Fro' from MSEDCL site to laboratory. The challenger would have the opportunity to select the sample from the store and any such challenge should be made within the guarantee period. The party challenged, challenger and the utility could witness the challenge testing.

The challenge testing would cover following tests:

1. Measurement of magnetizing current.
2. No load losses test.
3. Load losses test (at 100 % loading).
4. Temperature rise test.

The challenge test could be conducted at NABL Laboratory, like ERDA and CPRI. If the values are within the limits the products gets confirmed else not confirmed.

Following scenarios will be considered.

- 1) If the product is confirmed, the challenger has to bear the testing and transportation cost. Deposit amount will be forfeited.
- 2) If the product is not confirmed-
  - a) The manufacturer must pay the testing and transportation charges to challenger within 30 days from the reporting date.
  - b) Entire quantity supplied to MSEDCL will be considered as non confirming. Penalty of 1.5 times the testing fees and transportation 'To and Fro' from MSEDCL site to laboratory charges for all Power Transformer will be levied on the manufacturer.



**Technical Specification of 5 MVA and 10 MVA Power Transformer**

- c) The manufacturer will be prohibited from participating in tenders for next 5 years.
- d) Deposit will be returned to challenger by MSEDCL within 30 days.
- e) In case of heat run test (Temperature rise test), penalty will be INR 5 lacs per degree centigrade for the additional temperature rise in degree Celsius.

**28.0 Guaranteed & Technical Particulars:**

The bidder should fill up all the details in Schedule A and the statement such as “as per drawings enclosed”, “as per MSEDCL requirement” “as per IS” etc. shall be considered as details not furnished and such offers liable for rejection.

**29.0 Performance Guarantee:**

All Power transformers supplied against this specification shall be guaranteed for a period of 66 months from the date of receipt at the consignee’s Sites or 60 months from the date of commissioning, whichever is earlier. However, any engineering error, omission, wrong provisions, etc. which do not have any effect on the time period, shall be attended to as and when observed/ pointed out without any price implication.

**30.0 Cost Data Sheet :**

The bidders shall submit the cost data sheets indicating the break up prices and quantity of each raw material and components along with the unit rates required for manufacture the offered transformers along with the offer. The cost data sheet format is enclosed herewith. If the rates quoted are not justified with the cost data sheets, the offer shall not be considered for evaluation and placement of the order. The cost data sheets shall be scrutinized by MM cell section.

<b>Format for Cost Data-Item ----- kVA , ----- kV Power Transformer</b>					
Sr.No.	Particulars	Unit	Unit Rate (Rs)	Qty.	Amt (Rs.)
1	Core (M4 or better )	kg			
2	Copper for HV Winding	kg			
3	Copper for LV Winding	kg			
4	Insulation Paper	meters			
5	Oil	ltrs			
6	Tank	No.			
7	Channel	kg			
8	Radiator	kg			
9	Insulator / Bushing				
10	N2 Based Fire Protection System				
11	On Load Tap Changer with RTCC Panel				
12	Wastages@%	Lum Sum			

**Technical Specification of 5 MVA and 10 MVA Power Transformer**

**31.0 Schedules :**

a) The bidder shall fill in the following schedules which form part of the tender specification and offer. If the schedules are not submitted duly filled in with the offer, the offer shall be rejected.

Schedule `A' -Guaranteed Technical Particulars

Schedule `B' -Schedule of Tenderer's Experience.

Schedule `C' –Format for undertaking of use of imported prime CRGO steel laminations.

b) The discrepancies between the specification and the catalogs, Literatures and indicative drawings which are subject to change, submitted as part of the offer, shall not be considered and representation in this regard will not be entertained.

c) The Bidder shall submit the list of orders for similar type of equipments, executed or under execution during the last three years, with full details in the schedule of Tenderer's experience (Schedule `B') to enable the purchaser to evaluate the tender.

d) The bidder should submit undertaking for use of imported prime CRGO material with documentary evidence.

**Technical Specification of 5 MVA and 10 MVA Power Transformer**

**Schedule `A`**

**PRINCIPAL TECHNICAL PARAMETERS:**

Guaranteed Technical Particulars For 5 MVA & 10 MVA, 33/11KV Power Transformer.

Sr. No	PARTICULARS	MSEDCL REQUIREMENT	Technical Parameters
1	Brand Name & Manufacturer's Name	Mfg. to give detail	
2	Place of manufacturer	Mfg. to give detail	
3	Type (Indoor/Outdoor)	Indoor/Outdoor	
4	Normal KVA output	Mfg. to give detail	
a.	Continuous max. KVA rating as per IS 2026/1977 amended to date corresponding to a temp. rise of 50 deg. C (in oil) under max. Ambient temp. of 50 deg. C	Mfg. to give detail	
b.	Continuous max. KVA rating at site corresponding to 50 deg. C temp rise in oil with max. ambient temp of 50 deg. C	Mfg. to give detail	
5	Maximum Temperature rise for top oil over an ambient temperature of 50 °C should be 50 °C maximum (measured by thermometer in accordance with IS 2026 or relevant International Standard).	50 °C	
6	Maximum Temperature rise for winding over an ambient temperature of 50 °C should be 55 °C maximum (measured by resistance method in accordance with IS 2026 or relevant International Standard).	55 °C	
7	No. of phases	3	
8	Voltage between phases (HV Side) at normal tap 5, in volts	Mfg. to give detail	
9	Voltage between phases (LV Side) at normal tap 5, in volts	Mfg. to give detail	
9	Connections		
a.	On HV	Mfg. to give detail	
b.	On LV	Mfg. to give detail	

**Technical Specification of 5 MVA and 10 MVA Power Transformer**

10	Vector group	Dyn11	
11	Frequency	50 Hz with $\pm 3\%$ tolerance	
12	Tapings		
	i) Range	+5 % to -15 % in	
	ii) No. of steps	16 (of 1.25 % each)	
13	Method of cooling	ONAN	
14	Max. core losses at normal voltage & normal frequency-KW (without IS Tol.)	Mfg. to give detail	
15	Max. losses at max. voltage or at 110% voltage at normal frequency - KW (without IS Tol.)	Mfg. to give detail	
16.	Max. load losses at normal full load current- KW at 75 deg. C	Mfg. to give detail	
17	Resistance voltage drop of full load at normal tap at 75 deg. C in volts		
18	% Reactance drop on full load at normal tap at 75 deg. C	Mfg. to give detail	
19	% Impedance Voltage drop on full load at normal tap at 75 deg. C	Mfg. to give detail	
20	Current Density		
a.	Primary winding Amps per sq.mm.(Main & Tap)	Mfg. to give detail	
b.	Secondary winding Amps per sq.mm.	Mfg. to give detail	
21	Winding Resistance per phase in ohms at 75 deg..C	Mfg. to give detail	
a.	HV Winding ( main & Tap )	Mfg. to give detail	
b.	LV Winding	Mfg. to give detail	
22	No. of turns	Mfg. to give detail	
a.	HV Winding ( Main & Tap )	Mfg. to give detail	
b.	LV Winding	Mfg. to give detail	
23	Core	Mfg. to give detail	
24	Grade of laminations & type of core	Mfg. to give	

**Technical Specification of 5 MVA and 10 MVA Power Transformer**

		detail	
25	Core material used & thickness	Mfg. to give detail	
26	Type of core construction	Mfg. to give detail	
27	Winding insulation details	Mfg. to give detail	
25.1	Type of insulation of winding	Mfg. to give detail	
a.	HV side	Mfg. to give detail	
b.	LV side	Mfg. to give detail	
25.2	Class of insulation winding	Mfg. to give detail	
a.	HV side	Mfg. to give detail	
b.	LV side	Mfg. to give detail	
26	Guaranteed efficiency at standard reference temp. of 75 deg. C & normal voltage ratio in %	Mfg. to give detail	
a.	on 100% load at 1 p. f.	Mfg. to give detail	
b.	on 75% load at 1 p. f.	Mfg. to give detail	
c.	on 50% load at 1 p. f.	Mfg. to give detail	
d.	on 100% load at 0.8 lag p. f.	Mfg. to give detail	
e.	on 75% load at 0.8 lag p. f.	Mfg. to give detail	
27	Regulation on full load at 75 deg. C & normal voltage ratio in %	Mfg. to give detail	
a.	at 1 p.f.	Mfg. to give detail	
b.	at 0.8 p.f.(lag)	Mfg. to give detail	
28	Min. Clearance to earth	Mfg. to give detail	
a.	of primary winding in mm	Mfg. to give detail	
b.	of secondary winding in mm	Mfg. to give	

**Technical Specification of 5 MVA and 10 MVA Power Transformer**

		detail	
29	Impulse withstand voltage on high tension winding (stating nature of impulse ) KV	Mfg. to give detail	
30	Type of tank	Mfg. to give detail	
31	Total radiating surface sq.mt. (i.e. radiators, tank-tank body & top cover ). Furnish the calculations	Mfg. to give detail	
31.1	Heat generated by the transformer for the given losses in joules, furnish the calculations	Mfg. to give detail	
32	Noise level at a distance of 1 m.	Mfg. to give detail	
33	Weight in Kg	Mfg. to give detail	
a.	Weight of core	Mfg. to give detail	
b.	Weight of copper in primary (HV).(Main & Tap ) per phase	Mfg. to give detail	
c.	Weight of copper in secondary (LV) per phase	Mfg. to give detail	
d.	Weight of core coil assembly	Mfg. to give detail	
e.	Weight of lift for inspection (top cover)	Mfg. to give detail	
f.	Weight of conservator with oil	Mfg. to give detail	
	Weight of conservator without oil	Mfg. to give detail	
g.	Weight of tank with radiators	Mfg. to give detail	
h.	Weight of tank with oil & Term. Boxes (HV/LV)	Mfg. to give detail	
i.	Weight of one radiator with oil	Mfg. to give detail	
	without oil	Mfg. to give detail	
j.	Weight of OLTC with oil	Mfg. to give detail	
	without oil	Mfg. to give detail	
k.	<b>Weight of HV Cable Box</b>	Mfg. to give detail	
	<b>Weight of LV Cable Box</b>	Mfg. to give	

**Technical Specification of 5 MVA and 10 MVA Power Transformer**

		detail	
1.	Weight of Oil only	Mfg. to give detail	
	In Tank	Mfg. to give detail	
	In OLTC	Mfg. to give detail	
	In Conservator	Mfg. to give detail	
m.	Weight of transformer complete with oil & all accessories	Mfg. to give detail	
34	Quantity of Oil Liters	Mfg. to give detail	
a.	In Tank	Mfg. to give detail	
b.	In Conservator	Mfg. to give detail	
c.	In OLTC	Mfg. to give detail	
35	Overall dimensions when installed ( with accessories fitted)		
a.	Length (mm) 5200 mm	Mfg. to give detail	
b.	Width (mm) 4200 mm	Mfg. to give detail	
c.	Height (mm) 5800 mm	Mfg. to give detail	
36	Transport dimensions (L x Wx H)		
a.	Length (mm)	Mfg. to give detail	
b.	Width (mm)	Mfg. to give detail	
c.	Height (mm)	Mfg. to give detail	
37	Head room necessary to allow removal of core in meters	Mfg. to give detail	
38	Available clear space of 1 m ( considering the size of transformer bay & overall dimensions of transformer ) req. all round for adequate ventilation is sufficient		
39	OLTC	Mfg. to give detail	
39.1	Details of OLTC Gear	Mfg. to give	

**Technical Specification of 5 MVA and 10 MVA Power Transformer**

		detail	
a.	MVA Rating	Mfg. to give detail	
b.	Current Rating	Mfg. to give detail	
c.	Voltage Ratio	Mfg. to give detail	
d.	Type of connection	Mfg. to give detail	
39.2	Particulars of OLTC gear offered make & type of the OLTC. Performance certificates attached (Yes/No)	Mfg. to give detail	
39.3	Type & Routine test certificates from CPRI attached (Yes/No)	Mfg. to give detail	
a.	Overall dimensions	Mfg. to give detail	
b.	Step voltage	Mfg. to give detail	
c.	Max. Working current	Mfg. to give detail	
d.	Direction of power flow	Mfg. to give detail	
e.	Value & Wattage of transition resistor	Mfg. to give detail	
40	Type test certificates in respect of 5/10 MVA transformer with voltage class 33 KV and 22 KV	Mfg. to give detail	
41	List of supplier of raw materials like copper, core, transformer oil, insulating materials etc. Details about quality control methods adopted to assess the quality of raw/ finished material.	Mfg. to give detail	
42	List of plant machinery & testing equipments indicating their ratings & make, for carrying out all routine/acceptance tests & certain type tests such as Heat Run at full load, Impulse test, Noise level measurement etc.	Mfg. to give detail	
43	Drawings:	Mfg. to give detail	
a.	Dimensional drawings of the transformer with radiators, conservators etc. fitted. General arrangement drawing one sheet comprising of plan, elevation, side view of the complete transformer & other details like legends, untanking height, clearance etc. also all above drawings in separate sheets.	Mfg. to give detail	
b.	Transport outline of the transformer including transport weight	Mfg. to give detail	



**Technical Specification of 5 MVA and 10 MVA Power Transformer**

c.	Rating & Diagram plate. Connection diagram of the transformer winding showing the position of tapping etc.	Mfg. to give detail	
d.	Bushings (primary & secondary) drawings.	Mfg. to give detail	
e.	Cable box assembly (LV) drawing along with support arrangement	Mfg. to give detail	
f.	Cable box assembly (HV) drawing alongwith support arrangement	Mfg. to give detail	
g.	Dimensional drawings of the OLTC gear (internal details).	Mfg. to give detail	
h.	Schematic diagram of the OLTC arrangement for Transformer operating independently.	Mfg. to give detail	

**Technical Specification of 5 MVA and 10 MVA Power Transformer**

**Schedule `B'**

**SCHEDULES OF TENDERER'S EXPERIENCE**

Tenderer shall furnish here a list of similar orders executed/under execution by him to whom a reference may be made by Purchaser in case he considers such a reference necessary.

Sr. No.	Name of Client and Description of Item	Value of Order	Period of Supply and commissioning	Name and Address to whom Reference may be made
1	2	3	4	5

NAME OF FIRM\_\_\_\_\_

NAME & SIGNATURE OE TENDERER\_\_\_\_\_

DESIGNATION\_\_\_\_\_

DATE\_\_\_\_\_



**Technical Specification of 5 MVA and 10 MVA Power Transformer**

# **Annexure `I` Technical Specification For Transformer Oil**



Maharashtra State Electricity Distribution Company Limited

---

TECHNICAL SPECIFICATION NO. MSC /2019/ 01

TECHNICAL SPECIFICATION

FOR

**NEW INSULATING OIL as per IS 335 amended 2018**

FOR

**Transformers**

IN

MSEDCL

**Technical Specification of 5 MVA and 10 MVA Power Transformer**

**I N D E X**

Specifications for New Insulating Oil	
Clause No.	Contents
1.	Scope
2.	Service Condition
3.	Reference Standards
4.	General Technical Requirements
5.	ISI Certification mark
6.	Packing
7.	Sampling
8.	Tests
9.	Pre- dispatch Inspection
10.	Testing Facility
11.	Rejection
12.	Quality Assurance
13.	Qualifying Requirement
Specifications for Drums, Large, fixed Ends Grade “A ” Drums	
Clause No.	Contents
1.	Scope
2.	Reference
3.	Terminology
4.	Capacity
5.	Dimensions
6.	Material
7.	Construction
8.	Finish
9.	Tests
10.	Sampling
11.	Marking

**Technical Specification of 5 MVA and 10 MVA Power Transformer**

12.	Schedules <ol style="list-style-type: none"><li>1. Schedule A - Guaranteed Technical Particulars.</li><li>2. Schedule B – Tenderer’s Experience</li></ol>
-----	--

**Technical Specification of 5 MVA and 10 MVA Power Transformer**

**TECHNICAL SPECIFICATION NEW INSULATING OIL**  
SPECIFICATION NO. MSC/2019/01

**1.0 Scope :**

- 1.1 The specification covers manufacturing, sampling, testing, packing, marking and delivery of premium grade **Unused Mineral Insulating Oil (Type II)** for Transformers.
- 1.2 This specification prescribes the requirements of new insulating oil suitable for use as an insulating and heat transfer medium.
- 1.3 The Unused Mineral Insulating Oils are obtained by distillation and refining of crude petroleum.
- 1.4 The Unused Mineral Insulating oils shall be with normal oxidation resistance.

**2.0 Service Conditions:**

A) The Unused Mineral Insulating oil to be supplied against this specification shall be suitable for satisfactory continuous operation of power and distribution transformers under the following tropical conditions.

2.1 Maximum ambient temperature (Degree C)	....	50
2.2 Maximum temperature in shade (Degree C)	....	45
2.3 Minimum temperature of air in shade (Degree C)	....	3.5
2.4 Relative Humidity (%)	....	10 to 100
2.5 Maximum Annual Rainfall (mm)	....	1450
2.6 Maximum Wind Pressure (Kg/Sq.)	....	150
2.7 Maximum altitude above mean sea level (meter)	....	1000
2.8 Isoceraunic level (days/year)	....	50
2.9 Seismic level (Horizontal acceleration)	....	0.3

Moderately hot and humid tropical climate conducive to rust and fungus growth.

2.10 Reference Ambient Temperature for temperature rise : 50 Deg C

B) The climatic conditions are prone to wide variations in ambient conditions and hence the Unused Mineral Insulating oil shall be of suitable for satisfactory continuous operation of power and distribution transformers.

**3.0 Reference Standards:**

**3.1** Unless otherwise specified, the Unused Mineral Insulating oil to be supplied shall be conformed to Indian and International Standards amended up to date as follows:

Sr. No.	IS No.	Title
1	335/2018	New Insulating Oils - Specification (fifth revision)
2	1070 : 1992	Reagent grade water – specification ( third revision)
3	1448:[P:10/sec	Methods of test for petroleum and its products : Part 2

**Technical Specification of 5 MVA and 10 MVA Power Transformer**

	2]:2013	Acidity ( Second revision)
4	1448:[P:10]: 2013	Methods of test for petroleum and its products : Part 10 cloud point and pour point ( First revision)
5	1448:[P:16]: 2014 & 1448:[P:21]: 2012	Methods of test for petroleum and its products: Part 21 Flash Point ( closed) by Pensky Martens apparatus (Third revision)
6	1448:[P:25]: 1976	Methods of test for petroleum and its products: part 25 Determination of kinematics and dynamic viscosity ( First revision)
7	16084 :2013	Mineral Insulating Oils- determination of kinematics viscosity at very low temperatures.
8	1783:[Part1]: 1983	Drums, large, fixed ends: Part 1 Grade A Drums ( second revision)
9	1783:[Part 2]: 1988	Drums, large, fixed ends: Part 1 Grade A Drums ( third revision)
10	4759:1984	Hot-dip zinc coatings on structural steel and other allied products ( second revision)
11	6103:1971	Methods of test for specific resistance (resistivity) of electrical insulating liquids
12	ASTMD 971	Methods of test for interfacial tension of oil against water by the ring method.
13	6262:1971  16086 : 2013	Method of test for power factor and dielectric constant of electrical insulating liquids.  Insulating liquids – determination of the dielectric dissipation factor by measurement of the conductance and capacitance – test method.
14	6272:1971	Metal polishes (special)
15	6792:1992  6792:2017	Method for determination of electric strength of insulating oils  Insulating liquids – determination of the breakdown voltage

**Technical Specification of 5 MVA and 10 MVA Power Transformer**

		at power frequency – test method (second revision)
16	6855:2017	Method of sampling for liquid dielectric (second revision)
17	12177:1987	Methods of test for oxidative ageing of electrical insulation of petroleum oils by the open beaker method
18	12463:1988	Inhibited mineral insulating oils
19	IEC 60814/1997	Determination of water in insulating liquids and in oil-impregnated paper and press board by automatic coulometric Karl Fischer titration – Method of test
20	13631:2017	Method of test for detection and determination of antioxidant additives in insulating oils.(revision first)

**3.2** In case of conflict arising out due to variations between the applicable standard and the standards specified herein the provisions of this specification should prevail.

**4.0 General Technical Requirements:**

The characteristics of the Unused Mineral Insulating oil when it is sampled at manufacturer’s work or at the point of delivery and tested in accordance with the methods referred to in TABLE 2 of IS: 335: 2018 amended upto date.

**4.1 Function :-**

- i) The Viscosity of Unused Mineral Insulating oil shall be **maximum 15 (mm<sup>2</sup>/ s )** at 40 ° C as per IS 1448 [ P:25]:1976.
- ii) The Viscosity of Unused Mineral Insulating oil shall be maximum **1800 (mm<sup>2</sup>/ s )** at 0 ° C as per IS 1448 [ P:25]:1976.
- iii) Pour Point of the Unused Mineral Insulating oil should be minimum 10 ° C below the Lowest Cold Start Energizing Temperature (LCSET) i.e. **- 10 ° C** as per IS: 1448 [ P:10. Sec 2]:1970.
- iv) The Water content in the Unused Mineral Insulating oil shall be maximum **30 mg / kg** for bulk supply and **40 mg / kg** for delivery in drums as per IEC: 60814.
- v) As per IS 6792:1992 the Breakdown voltage of Unused Mineral Insulating oil shall be as follows.
  - a) The Breakdown voltage of Unused Mineral Insulating oil should be minimum **30 KV (rms) at.2.5 mm gap.**
  - b) The Breakdown voltage of **before Laboratory treatment** should be minimum **70 KV (rms) after Laboratory treatment at 2.5 mm gap.**
- vi) The Density of Unused Mineral Insulating oil shall be **maximum 0.895 g / cm<sup>3</sup> at 20 ° C** as per IS 1448 [ P:16]:1990.



### Technical Specification of 5 MVA and 10 MVA Power Transformer

- vii) As per IS: 16086 the Dielectric Dissipation Factor (DDF ) of Unused Mineral Insulating oil shall be maximum **0.005** ( $\tan \delta$ ) at 90 ° C .
- viii) Particle Content in drum at delivery of the Unused Mineral Insulating oil is as per IS : 13236.

#### 4.2 Refining / Stability :-

- i) The appearance of the Unused Mineral Insulating oil shall be clear, free from sediments (impurities) and suspended matter.
- ii) The Unused Mineral Insulating oil should be Neutral and free from any acidic compound. Total Acidity of Unused Mineral Insulating oil shall be maximum **0.01 mg/KOH/gm** as per IEC : 62021 – 1.
- iii) Interfacial tension of the Unused Mineral Insulating oil shall be minimum 40mN / m as per ASTM D971.
- iv) Total sulphur content in the Unused Mineral Insulating oil shall be maximum 0.05 % before oxidation test. as per ISO 14596 or ASTM D4294.
- v) The Corrosive Sulphur in the Unused Mineral Insulating oil shall be **Non-Corrosive**. The Corrosive Sulphur in the Unused Mineral Insulating oil shall be measured as per DIN 51353.
- vi) The Potential Corrosive Sulphur in the Unused Mineral Insulating oil shall be **Non-Corrosive**. The Potential Corrosive Sulphur in the Unused Mineral Insulating oil shall be measured as per IS : 16310.
- vii) Dibenzyl Disulfide (DBDS) in the Unused Mineral Insulating oil should not be detectable ( < 5 mg / kg ) as per IS : 16497 ( Part 1 ).
- viii) The Unused Mineral Insulating oil should be uninhibited ( U ) as per IS : 13631 / IEC : 60666. Inhibited in the Unused Mineral Insulating oil should not be detectable ( < 0.01 % ) as per IS : 13631 / IEC : 60666.
- ix) Metal Passivator additives in the Unused Mineral Insulating oil should not be detectable ( < 5 mg / kg ) as per IS : 13631 / IEC : 60666.
- x) Oxidation Stability can be improved by incorporation of Antioxidant additive in the Unused Mineral Insulating oil. Oxidation Stability is measured in accordance with IS : 12422.
- xi) 2- Furfural and related compound content in the Unused Mineral Insulating oil should not be detectable ( < 0.05 mg / kg for each individual compound ) as per IS : 15668.

#### 4.3 Performance :-

- i) Oxidation Stability can be improved by incorporation of Antioxidant additive and metal passivator additives in the Unused Mineral Insulating oil. Oxidation Stability is measured in accordance with IS : 12422 with Test Duration 164 hrs. At the end of Oxidation Stability Test following limits should be observed:
  - a) Total acidity : Maximum 1.2 mg KOH / gm.
  - b) Sludge : Maximum 0.8 %.
  - c) Dielectric Dissipation Factor ( DDF ) at 90 ° C : Maximum 0.500.
- ii) Gassing Tendency is caused in equipment with high electrical field stress or special design , gasses formed when subjected to Corona Partial Discharges and shall be absorbed

## Technical Specification of 5 MVA and 10 MVA Power Transformer

by the Unused Mineral Insulating oil, Gassing Tendency shall be as per IEC : 60628, Method A.

- iii) Stray Gassing means production of gasses such as hydrogen, hydrocarbons carbon oxides at low temperatures ( < 120° C ) without thermal or electrical faults in transformer, sometimes even without operational stress. This phenomenon could result in high production of gases and a misinterpretation of Dissolved Gas Analysis ( DGA ) results.
- iii) Electrostatic Charging Tendency ( ETC ) of the Unused Mineral Insulating oil is an important for certain design of HV transformer which have oil pumping rates that can give rise to the build- up of electrostatic charge. This can result in energy discharge causing transformer failure. Electrostatic Charging Tendency ( ETC ) can be reduced by using metal passivator additives such as Benzotriazole ( BTA ) and 5-methyl-1H-Benzotriazole ( TTA ). Electrostatic Charging Tendency ( ETC )'s measurement as per CIGRE Technical Brochure 170.

### 4.4 Health, Safety and Environment ( HSE ) :-

- i) Flash point of the Unused Mineral Insulating oil measured by Pensky Marten apparatus shall be **minimum 135 ° C** as per IS: 1448 [ P:21]:1992.
- ii) Polycyclic Aromatics ( PCA ) content of the Unused Mineral Insulating oil detectable by extraction with Dimethylsulfoxide ( DMSO ) under the condition of IP 346, shall be maximum 3 % .
- iii) Polychlorinated Biphenyls ( PCB ) content of the Unused Mineral Insulating oil should not be detectable ( < 2 mg / kg ) as per IS : 16082.

### 5.0 ISI Certification mark for Unused Mineral Insulating oil:-

The Unused Mineral Insulating oil is to be supplied confirming to IS-335-2018 as amended upto date should bear ISI certification mark, without ISI mark insulating oil will rejected.

### 6.0 Packing :-

- 6.1 The Unused Mineral Insulating oil shall be delivered in perfectly clean steel drums of 210 liters nominal capacity conforming to Grade “A” type 2 conforming IS: 1783 ( Part 1 ) : 1993 amended upto date. The drum shall be coated from inside with epoxy lacquer of phosphate coating or better. The inside coating of the drum shall be resistant to Unused Mineral insulating oil. The outside surface of the drum may be coated with anticorrosive primer and finish paint, for protection against atmospheric corrosion. The colour of the finishing paint shall be Navy Blue (Shade No. 106) conforming to IS:5:1994 (Colours of ready mixed paints). The drum shall be effectively sealed immediately after filling the oil to avoid ingress of moisture.

### 6.2 Steel Barrel:-

The Unused Mineral Insulating oil of above specification shall be supplied in standard packing of 200 liters nominal capacity, non-returnable Brand New Steel Barrels (Drums) `A` grade type-2 conforming to IS-1783 (Part-I) 1993 as amended upto date.

## **Technical Specification of 5 MVA and 10 MVA Power Transformer**

*The Type-2 drums shall be as per Fig-2 with triple / Spiral seam (Drawings No. MSEDCL/MM-II/OIL/01 and MSEDCL/MM-II/OIL/02 ) with ISI marking.*

### **7.0 Sampling :**

Sampling of Unused Mineral Insulating oil shall be done in accordance with IS 6885: 1973.

### **8.0 Tests :**

The tenderer shall submit Test reports of the offered Unused Mineral Insulating oil with the offer in electronic format (i.e. Pen Drive) and in physical format. The tests shall be carried out at laboratories accredited by National Accreditation Board for testing and Calibration Laboratories (NABL) such as CPRI/ERDA to prove the requirements specified in this specification & as per relevant standards IS:335, 2018 amended up-to-date. The tests should be carried out within 5 years prior to the date of opening of this tender. The offer without test reports from NABL laboratories is considered as non- responsive and likely to be rejected.

The successful tenderer shall get approved the test reports of Unused Mineral Insulating oil and drum from Chief Engineer (MMC), MSEDCL, Prakashgad, Bandra, Mumbai prior commencement of the supply. The Drum drawings shall be submitted to the Chief Engineer (MMC) and get approved before commencement of the supply.

### **9.0 Pre dispatch Inspection:**

The tenderers should arrange for sample testing of Unused Mineral Insulating oil twice during the contractual period, at their cost. Tenderer's should note that no separate testing charges will be payable by the MSEDCL. Sample testing will have to be arranged as and when directed by the MSEDCL at CPRI, Bangalore/ERDA, Vadodara Laboratories.

### **10.0 Testing Facility :**

10.1 The tenderer should have adequate testing facility for all routine and acceptance tests on Unused Mineral Insulating oil and should provide the testing arrangements and testing equipments to testing Engineer of MSEDCL. The tenderer should submit the list of testing equipments available with them with the offer.

10.2 The bidder should also supply along with his offer the pamphlets/literatures in respect of Unused Mineral Insulating oil available with them.

### **Technical Specification of 5 MVA and 10 MVA Power Transformer**

- 10.3 The bidder should not change GTP parameters of Unused Mineral Insulating oil once it offered in A/T, and Type Test Reports.

#### **11.0 Rejection :-**

Apart from rejection due to failure in testing of Unused Mineral Insulating oil to meet the specified test requirements the Unused Mineral Insulating oil shall be liable for rejection on any one of the following reasons.

- i. If tests are not carried out as per clause no. 7.0 of this specification.
- iv. If Drawings are not submitted with offer as per clause no. 5.2 of this specification.
- v. If GTP parameters are not submitted as per clause no. 4.0 of this specification.
- vi. The bidder should fill up all the details in GTP parameter list, the statement such as “as per drawings enclosed”, “as per MSEDCL’s requirement” “as per IS” etc. shall be considered as details are not furnished and such offers shall liable for rejection.

#### **12.0 Quality Assurance**

- 12.1 Names of the supplier for the raw material, list of standards accordingly to which the raw materials are tested, list of test normally carried out on raw materials in presence of bidder’s representatives, copies of test certificates.
- 12.2 Information and copies of test certificate as in (i) above respect of bought out accessories.
- 12.3 List of manufacturing facilities available.
- 12.4 Level of automation achieved and list of areas where manual processing still exists.
- 12.5 List of areas in manufacturing process where stage inspection are normally carried out for quality control and details of such tests and inspections.
- 12.6 List of testing equipment available with the bidder for final testing of Unused Mineral Insulating oil and test plant limitation, if any, vis-à-vis the special acceptance and routine tests specified in the relevant standards and the present specification.
- 12.7 The successful bidder shall submit the Routine Test Certificate along with documentary evidence having paid for the excise duty for the following raw materials viz Crude Petroleum, at the time of Testing.

#### **13.0 Qualifying Requirement:**

- 13.1 The Tenderer must be a manufacturer of Unused Mineral Insulating oil.
- 13.2 The tenderer having ISO certificate for their manufacturing unit for Unused Mineral Insulating oil shall be given preference.
- 13.3 The bidder should have proven experience of not less than 5 years in Manufacture, supply and testing at works for offered Unused Mineral Insulating oil.
- 13.4 The bidder should have adequate in house testing facilities for conducting acceptance tests in accordance with relevant IS.

**Technical Specification of 5 MVA and 10 MVA Power Transformer**

- 13.5 Bidder should have a minimum turnover of 60% of the value of the material offered in any one financial year during the previous 3 years. However, being a commercial aspect this point may be verified by mm cell.
- 13.6 The Bidder should furnish all the relevant documentary evidence to establish the fulfillment of the above requirement.
- 13.7 The bidders not meeting the requirement at clause No. 12.1 can also participate, provided they have valid ongoing collaboration with a manufacturer who has at least 10 years experience in the manufacturing and testing of offered Unused Mineral Insulating oil, which have been in satisfactory service for a period of at least seven years. In such an event the bidder shall furnish along with the bid the documentary evidence for the same and undertaking from the bidder and collaboration accepting joint and several liability for all obligations under the contract.
- 13.8 The bidder who does not meet the above Qualifying requirement of experience (Clause No. 12.3) may be considered for a Trial Order subject to fulfilling the following requirements along with Clause Nos. 12.1 to 12.7.
- 13.9 The bidder shall have the basic infrastructure for the manufacture and supply of the Unused Mineral Insulating oil offered, like machinery, technical knowledge, capacity etc.
- 13.10 The purchaser should be satisfied with the manufacturing, supplying and financial capacity of the bidder after inspecting the bidder's works.
- 13.11 Notwithstanding anything stated above, the purchaser's decision in this regard will be final.



**Technical Specification of 5 MVA and 10 MVA Power Transformer**

**Annexure `II'  
Technical Specification for Nitrogen Injection Fire  
Protection System**



Maharashtra State Electricity Distribution Company Limited

---

TECHNICAL SPECIFICATION

FOR

NITROGEN INJECTION FIRE  
PROTECTION SYSTEM

FOR

DISTRIBUTION SYSTEM

IN

MSEDCL

**Technical Specification of 5 MVA and 10 MVA Power Transformer**

**I N D E X**

<b>Clause No.</b>	<b>Contents</b>
1	Scope
2	System Particulars
3	Service Condition
4	Applicable Standards
5	Activation of the Fire Protective System
6	General description
7	Operation
8	System components
9	Others Items
10	Technical Particulars
11	Mandatory Spares
12	Tests
13	Documentation

**Technical Specification of 5 MVA and 10 MVA Power Transformer**

**MAHARASHTRA STATE ELECTRICITY DISTRIBUTION CO. LTD.**

**TECHNICAL SPECIFICATION FOR**

**NITROGEN INJECTION FIRE**

**PROTECTION SYSTEM**

**3 Scope:-**

Nitrogen injection Fire Protection System (NIFPS) shall use nitrogen as fire quenching medium. The protective system shall prevent Transformer/Reactor's oil tank explosion and possible fire in case of internal faults. In the event of fire by external causes such as bushing fire, OLTC fires, fire from surrounding equipments etc, it shall act as fast and effective fire fighter. It shall accomplish its role as fire preventer and extinguisher without employing water and/or carbon dioxide. Fire shall be extinguished within 3 minutes (Maximum) of system activation and within 3 seconds (Maximum) of commencement of nitrogen injection.

**4 System Particulars:-**

4.1	Nominal System Voltage	:	33 kV	22 kV	11kV
4.2	Voltage variation on supply side	:	± 10 %		
4.3	Corresponding Highest System Voltage	:	36 kV	24 kV	12kV
4.4	Frequency	:	50 Hz with ± 3 % tolerance		
4.5	Transient condition	:	-20 % or + 10 % combined variation of voltage and frequency.		

**3. Service Conditions :**

**A)** The Nitrogen injection Fire Protection System to be supplied against this specification shall be suitable for satisfactory continuous operation under the following tropical conditions.

3.1	Maximum ambient temperature (Degree C)	50
3.2	Maximum temperature in shade (Degree C)	45
3.3	Minimum Temperature (Degree C)	3.5
3.4	Relative Humidity (percent)	10 to 95
3.5	Maximum Annual rain fall (mm)	1450
3.6	Maximum wind pressure (kg/sq.m)	150
3.7	Maximum altitude above mean sea level ( Meter)	1000
3.8	Isoceranic level (days per year)	50



## Technical Specification of 5 MVA and 10 MVA Power Transformer

3.9 Siesmic level (Horizontal Acceleration) 0.3 g

Moderately hot and humid tropical climate conducive to rust and fungus growth

**B)** The climatic conditions are prone to wide variations in ambient conditions and hence the equipment shall be of suitable design to work satisfactorily under these conditions.

#### 4. Applicable Standards:

The design and installation of the complete fire protection system shall comply with the latest applicable Indian Standards. Wherever Indian Standards are not available relevant British/I.E.C. codes shall be followed. The following standards /codes shall be followed in particular.

a) Approval certificate from Loss Prevention Association.

b) National fire Codes 1993 of National Fire protection Association (NFPA) USA.

The entire fire protection system shall be designed, erected and commissioned in accordance with the regulation of Tariff Advisory Committee (TAC). In absence of TAC regulations NFPA regulation shall be adhered to.

#### 5.0 Activation of the Fire Protective System:

Mal-functioning of fire prevention/extinguishing system could lead to interruption in power supply. The supplier shall ensure that the probability of chances of malfunctioning of the fire protective system is particularly Zero. To achieve this objective, the supplier shall [plan out his scheme of activating signals which should not be complicated to make the fire protective system inoperative in case of actual need. The system shall be provided with automatic control for fire prevention fire extinction. Besides automatic control, remote electrical push button control at control box and local manual control in the fire extinguishing cubicle shall also be provided. The following electrical signals shall be required for activating the fire protective system under prevention mode /fire extinction mode.

##### a) Auto mode :

1) For prevention of fire :

i. Differential relay operation.

ii. Buchholz relay paralleled with pressure relief valve or RPRR(Rapid pressure Rise Relay).

iii. Tripping of all circuit breakers (On HV& LV side) associated with transformer /reactor is the pre-requisite for activation of system.

2) For extinguishing fire :

i) Fire detector.

ii) Buchholz relay paralleled with pressure relief valve (PRV) or Sudden Pressure Relay (SPR).

iii) Tripping of all circuit breakers (On HV& LV side) associated with transformer /reactor is the pre-requisite for activation of system.

##### b) Manual Mode (Local/Remote) :

## Technical Specification of 5 MVA and 10 MVA Power Transformer

Tripping of all circuit breakers (On HV & LV side) associated with transformer/reactor is the pre-requisite for activation of system.

**c) Manual Mode (Mechanical) :**

Tripping of all circuit breakers (On HV & LV side) associated with transformer/reactor is the pre-requisite for activation of system.

The system shall be designed to be operated manually in case of failure of power supply to fire protection system.

### 6.0 General description:

Nitrogen injection fire protection system should be a dedicated system for each oil filled transformer/reactor. It should have a Fire Extinguishing Cubicle (FEC) placed on a plinth at a suitable distance away from transformer/reactor. The FEC shall be connected to the top of transformer reactor oil tank for depressurization of tank and to the oil pit (capacity is approximately equal to 10 % of total volume of oil in transformer/reactor tank) from its bottom through oil pipes. The fire extinguishing cubicle should house a pressurized nitrogen cylinder(s) which is connected to the oil tank of transformer/reactor oil tank at bottom. The Transformer Conservator Isolation Valve (TCIV) is fitted between the conservator tank and Buchholz relay.

Cable connections are to be provided from signal box to the control box in the control room, from control box to the extinguishing cubicle and from TCIV to the signal box. Fire detectors placed on the top of transformer/reactor tank are to be connected in parallel to the signal box by Fire survival cables. Control box is also to be connected to relay panel in control room for receiving system activation signals.

### 7.0 Operation:

On receipt of all activating signals, the system shall drain pre-determined volume of hot oil from the top of tank (i.e. top oil layer), through outlet valve, to reduce tank pressure by removing top oil and simultaneously injecting nitrogen gas at high pressure for stirring the oil at pre-fixed rate and thus bringing the temperature of top oil layer down. Transformer conservator isolation valve blocks the flow of oil from conservator tank in the case of tank rupture / explosion or bushing bursting. Nitrogen occupies the space created by oil drained out and acts as an insulating layer over oil in the tank and thus preventing aggravation of fire.

### 8.0 System components :

Nitrogen injection fire protection system shall broadly consist of the following components. However, all other components which are necessary for fast reliable and effective working of the fire protective system shall be deemed to be included in the scope of the supply.

**a) Fire Extinguishing Cubicle (FEC) :**

The FEC shall be made of CRCA sheet of 3 mm (minimum) thick complete with the base frame, painted inside and outside with post office red color (shade 538 of IS -5). It shall have hinged split doors fitted with high quality tamper proof lock. The degree of protection shall be IP55. The following items shall be provided in the FEC.

- a) Nitrogen gas cylinder with regulator and falling pressure electrical contact manometer.
- b) Oil drain pipe with mechanical quick drain valve.

**Technical Specification of 5 MVA and 10 MVA Power Transformer**

- c) Control equipment for draining of oil of pre-determined volume and injecting regulated volume of nitrogen gas.
  - d) Pressure monitoring switch for back-up protection for nitrogen release.
  - e) Limit switches for monitoring of the system.
  - f) Butterfly valve with flanges on the top of panel for connecting oil drain pipe and nitrogen injection pipes for transformer/reactors.
  - g) Panel lighting (CFL Type).
  - h) Oil drainpipe extension of suitable sizes for connecting pipes to oil pit.
- b) Control box :**  
Control box is to be placed in the control room for monitoring system operation, automatic control and remote operation. The following alarms, indications, switches, push buttons, audio signal etc. shall be provided.
- a) System on
  - b) TCIV open
  - c) Oil drain valve closed
  - d) Gas inlet valve closed
  - e) TCIV closed\*
  - f) Fire detector trip\*
  - g) Buchholz relay trip
  - h) Oil drain valve open\*
  - i) Extinction in progress\*
  - j) Cylinder pressure low\*
  - k) Differential relay trip
  - l) PRV / SPR trip
  - m) Transformer/reactor trip
  - n) System out of service \*
  - o) Fault in cable connecting fault fire detector
  - p) Fault in cable connecting differential relay
  - q) Fault in cable connecting Buchholz relay
  - r) Fault in cable connecting PRV / SPR
  - s) Fault in cable connecting Transformer / reactor trip.
  - t) Fault in cable connecting TCIV
  - u) Auto/ Manual/ Off
  - v) Extinction release on/off
  - w) Lamp test
  - x) Visual/ Audio alarm\*
  - y) Visual/ Audio alarm for DC supply fall\*
- \* Suitable provision shall be made in the control box , for monitoring of the system from remote substation using the substation automation system.
- c) Transformer Conservator Isolation Valve :**  
Transformer conservator isolation valve(TCIV) to be fitted in the conservator pipe line, between conservator and Buchholz relay which shall operate for isolating the conservator during abnormal flow of oil due to rupture / explosion of tank or bursting of bushing. The valve shall not isolate conservator during normal flow of oil during

### **Technical Specification of 5 MVA and 10 MVA Power Transformer**

- filtration or filling or refilling, locking plates to be provided with handle for pad locking. It shall have proximity switch for remote alarm, indication with visual position indicator. The TCIV should be of the best quality as malfunctioning of TCIV could lead to serious consequence. The closing of TCIV means stoppage of breathing of transformer / reactor. Locking plates shall be provided for pad locking.
- d) Fire detectors :**  
The system shall be complete with adequate number of fire detectors (quartz bulb) fitted on the top cover of the transformer / reactor oil tank.
- e) Signal box :**  
It shall be mounted away from transformer / reactor main tank, preferably near the transformer marshaling box, for terminating cable connections from TCIV & fire detectors and for further connection to the control box. The degree of protection shall be IP55.
- f) Cables :**  
Fire survival cables (capable to withstand 750 deg. C) of 4 core x 1.5 sq. mm size for connection of fire detectors in parallel shall be used. The fire survival cable shall conform to BS 7629-1, BS 8434-1, BS 7629-1 and BS 5839-1, BS EN 50267-2-1 or relevant Indian standards.  
Fire Retardant Low Smoke( FRLS ) cable of 12 core x 1.5 sq. mm size shall be used for connection of signal box / marshaling box near transformer / reactor and FEC mounted near transformer / reactor with control box mounted in control room.  
Fire Retardant Low Smoke(FRLS) cable of 4 core x 1.5 sq. mm size shall be used for connection between control box to DC and AC supply source, fire extinguishing cubicle to AC supply source, signal box / marshaling to transformer conservator isolation valve connection on transformer.
- g) Pipes :**  
Pipes complete with connections, flanges, bends and tees etc. shall be supplied along with the system. Pipes and welding shall be sufficiently passivated and environment protected.
- 9.0 Others Items :**
- a)** Oil drain and nitrogen injection openings with gate valves on transformer / reactor tank at suitable locations.
- b)** Flanges with dummy piece in conservator pipe between Buchholz relay and conservator tank for fixing TCIV.
- c)** Fire detector brackets on transformer / reactor tank top cover.
- d)** Spare potential free contacts for activating the system i.e differential relay, Buchholz relay, Pressure relief device /RPRR, circuit breaker of transformer / reactor.
- e)** Pipe connections between transformer / reactor and FEC and between FEC and **oil pit** required for collection top oil.
- f)** Cabling for fire detectors mounted on transformer / reactor top cover.
- g)** Inter cabling between signal box , control box and Fire Extinguishing Cubicle(FEC).  
All external cables from / to the system i.e signal box to control box and control box to FEC shall be provided by the purchaser. All internal cables within the system i.e

**Technical Specification of 5 MVA and 10 MVA Power Transformer**

between detectors /signal box /marshaling box/FEC/TCIV shall be in the scope of NIFPS supplier .

- h) Butterfly valves / Gate valves on oil drain pipe and nitrogen injection pipe which should be able to withstand full vacuum.
- i) Supports valves, signal box etc. which are to be painted with enameled paint.

**10.0 Technical Particulars :**

Sr. No.	Particulars	Details
1.	Fire extinction period from commencement of Nitrogen Injection	30Sec(Max)
2.	Fire extinction period from the moment of system activation.	3 minutes.(Max)
3.	Fire detectors heat sensing temperature	Vendor to specify
4.	Heat sensing area per detector	Vendor to specify
5.	Transformer conservator isolation valve setting-min	Vendor to specify
6.	Capacity of nitrogen cylinder	Vendor to specify
7.	Power supply	
	a) For control	30/110 DC, variation -15%,+10 %
	b) For service/lighting	250 V AC , Variation +/- 10 %

The doors, removable covers and panels shall be gasketed all round with neoprene gaskets.

**11.0 Mandatory Spares :**

- a) Cylinder filled with Nitrogen of required capacity per substation :- 1.No.
- b) Fire detectors per transformer :- 3 No.
- c) Regulator assembly per substation :- 1 No.

**12.0 Tests :**

Reports of all type tests conducted as per relevant IS/IEC standards in respect of various bought out items including test reports for degree of protection for FEC/control box/signal box shall be submitted by the supplier.

The supplier should demonstrate the functional test associated with the following

- a) Fire extinguishing cubicle, control box.
- b) Fire detector.
- c) Transformer Conservator Isolation Valve.

The performance test of the complete system shall be carried out after erection of the system with transformer at site.

**13.0 Documentation:**

- a) To be submitted along with offer :
  - General outline of the system.
  - Detailed write-up on operation of the offered protection system including maintenance and testing aspects / schedules.

**Technical Specification of 5 MVA and 10 MVA Power Transformer**

Technical Data Particulars (GTP).

Data regarding previous supplies , date of commissioning, performance feedback etc.

**b)** To be submitted after award of contract :

Detailed dimensional layout drawing of the system with complete bill of materials, clearances from ground and other live points, details of detectors ,equipment layout, drawings ,detailed drawings pertaining to signal box, control box, FEC equipment, wiring and schemes,4 sets of testing, commissioning ,Operation and Maintenance manual along with soft copies (in CDs) shall be submitted by supplier.

**Technical Specification of 5 MVA and 10 MVA Power Transformer**

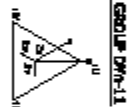
<p><b>NAME OF MANUFACTURE</b> ADDRESS _____</p>		<p><b>MAHARASHTRA ELECTRICITY DISTRIBUTION</b></p>																																																																																																													
<p>COOLING: _____                  RATING: _____                  NO. LINES: _____                  VOLTAGE: _____                  FULL LOAD CURRENT: _____                  SHORT CIRCUIT CURRENT: _____                  SHORT CIRCUIT VOLTAGE: _____                  SHORT CIRCUIT REACTANCE: _____                  SHORT CIRCUIT IMPEDANCE: _____                  SHORT CIRCUIT LOSS: _____                  SHORT CIRCUIT REACTANCE: _____                  SHORT CIRCUIT IMPEDANCE: _____                  SHORT CIRCUIT LOSS: _____</p>	<p>WINDING: _____                  L.V. VOLTAGE: _____                  L.V. AMPERES: _____                  H.V. VOLTAGE: _____                  H.V. AMPERES: _____                  H.V. SHORT CIRCUIT CURRENT: _____                  H.V. SHORT CIRCUIT VOLTAGE: _____                  H.V. SHORT CIRCUIT REACTANCE: _____                  H.V. SHORT CIRCUIT IMPEDANCE: _____                  H.V. SHORT CIRCUIT LOSS: _____</p>	<p>WINDING: _____                  L.V. VOLTAGE: _____                  L.V. AMPERES: _____                  H.V. VOLTAGE: _____                  H.V. AMPERES: _____                  H.V. SHORT CIRCUIT CURRENT: _____                  H.V. SHORT CIRCUIT VOLTAGE: _____                  H.V. SHORT CIRCUIT REACTANCE: _____                  H.V. SHORT CIRCUIT IMPEDANCE: _____                  H.V. SHORT CIRCUIT LOSS: _____</p>	<p>WINDING: _____                  L.V. VOLTAGE: _____                  L.V. AMPERES: _____                  H.V. VOLTAGE: _____                  H.V. AMPERES: _____                  H.V. SHORT CIRCUIT CURRENT: _____                  H.V. SHORT CIRCUIT VOLTAGE: _____                  H.V. SHORT CIRCUIT REACTANCE: _____                  H.V. SHORT CIRCUIT IMPEDANCE: _____                  H.V. SHORT CIRCUIT LOSS: _____</p>																																																																																																												
<p>MATERIAL OF WINDINGS: COPPER</p> <p>PROPERTY OF: M.S.D.CO.LTD.</p>		<p>VECTOR GROUP: DYN-11</p> 																																																																																																													
<p>TABLE</p> <table border="1" style="width:100%; border-collapse: collapse;"> <thead> <tr> <th>TRAP NO.</th> <th>VOLTAGE</th> <th>A.M.P.</th> <th>RESISTANCE CONNECTION O.L.T.C.</th> <th>REACTANCE CONNECTION O.L.T.C.</th> <th>VOLTAGE AMPERES</th> </tr> </thead> <tbody> <tr><td>1</td><td></td><td></td><td></td><td></td><td></td></tr> <tr><td>2</td><td></td><td></td><td></td><td></td><td></td></tr> <tr><td>3</td><td></td><td></td><td></td><td></td><td></td></tr> <tr><td>4</td><td></td><td></td><td></td><td></td><td></td></tr> <tr><td>5</td><td></td><td></td><td></td><td></td><td></td></tr> <tr><td>6</td><td></td><td></td><td></td><td></td><td></td></tr> <tr><td>7</td><td></td><td></td><td></td><td></td><td></td></tr> <tr><td>8</td><td></td><td></td><td></td><td></td><td></td></tr> <tr><td>9</td><td></td><td></td><td></td><td></td><td></td></tr> <tr><td>10</td><td></td><td></td><td></td><td></td><td></td></tr> <tr><td>11</td><td></td><td></td><td></td><td></td><td></td></tr> <tr><td>12</td><td></td><td></td><td></td><td></td><td></td></tr> <tr><td>13</td><td></td><td></td><td></td><td></td><td></td></tr> <tr><td>14</td><td></td><td></td><td></td><td></td><td></td></tr> <tr><td>15</td><td></td><td></td><td></td><td></td><td></td></tr> <tr><td>16</td><td></td><td></td><td></td><td></td><td></td></tr> <tr><td>17</td><td></td><td></td><td></td><td></td><td></td></tr> </tbody> </table>		TRAP NO.	VOLTAGE	A.M.P.	RESISTANCE CONNECTION O.L.T.C.	REACTANCE CONNECTION O.L.T.C.	VOLTAGE AMPERES	1						2						3						4						5						6						7						8						9						10						11						12						13						14						15						16						17						<p>NOTE:-</p> <ol style="list-style-type: none"> <li>ACTUAL DIMENSIONS SHALL BE INDICATED AT THE TIME OF DELIVERY.</li> <li>READ THE DIMENSIONS OF WINDING FROM X-X &amp; Y-Y THE INTERNAL.</li> </ol>	
TRAP NO.	VOLTAGE	A.M.P.	RESISTANCE CONNECTION O.L.T.C.	REACTANCE CONNECTION O.L.T.C.	VOLTAGE AMPERES																																																																																																										
1																																																																																																															
2																																																																																																															
3																																																																																																															
4																																																																																																															
5																																																																																																															
6																																																																																																															
7																																																																																																															
8																																																																																																															
9																																																																																																															
10																																																																																																															
11																																																																																																															
12																																																																																																															
13																																																																																																															
14																																																																																																															
15																																																																																																															
16																																																																																																															
17																																																																																																															
<p>NAME OF MANUFACTURE</p>		<p>ALL DIMENSIONS ARE IN MM.</p>																																																																																																													
<p>RATING &amp; TERMINAL MARKING PLATE FOR _____ KVA _____ KV POWER TRANSFORMER</p>		<p>DATE: _____</p> <p>DESIGNED BY: _____</p> <p>CHECKED BY: _____</p> <p>APPROVED BY: _____</p>																																																																																																													

MAHARASHTRA ELECTRICITY DISTRIBUTION

THIS IS AN INDICATIVE DRAWING

**Technical Specification of 5 MVA and 10 MVA Power Transformer**

**THIS IS AN INDICATIVE DRAWING**

NO.	DESCRIPTION	UNIT
01.	CONTRACTOR EQUIPMENT FOR	NO.
02.	ON-COMMISSIONING	NO.
03.	REPAIRS OF THE TRANSFORMER	NO.
04.	REPAIRS OF THE TRANSFORMER	NO.
05.	REPAIRS OF THE TRANSFORMER	NO.
06.	REPAIRS OF THE TRANSFORMER	NO.
07.	REPAIRS OF THE TRANSFORMER	NO.
08.	REPAIRS OF THE TRANSFORMER	NO.
09.	REPAIRS OF THE TRANSFORMER	NO.
10.	REPAIRS OF THE TRANSFORMER	NO.
11.	REPAIRS OF THE TRANSFORMER	NO.
12.	REPAIRS OF THE TRANSFORMER	NO.
13.	REPAIRS OF THE TRANSFORMER	NO.
14.	REPAIRS OF THE TRANSFORMER	NO.
15.	REPAIRS OF THE TRANSFORMER	NO.
16.	REPAIRS OF THE TRANSFORMER	NO.
17.	REPAIRS OF THE TRANSFORMER	NO.
18.	REPAIRS OF THE TRANSFORMER	NO.
19.	REPAIRS OF THE TRANSFORMER	NO.
20.	REPAIRS OF THE TRANSFORMER	NO.
21.	REPAIRS OF THE TRANSFORMER	NO.
22.	REPAIRS OF THE TRANSFORMER	NO.
23.	REPAIRS OF THE TRANSFORMER	NO.
24.	REPAIRS OF THE TRANSFORMER	NO.
25.	REPAIRS OF THE TRANSFORMER	NO.
26.	REPAIRS OF THE TRANSFORMER	NO.
27.	REPAIRS OF THE TRANSFORMER	NO.

NO.	DESCRIPTION	UNIT
28.	REPAIRS OF THE TRANSFORMER	NO.
29.	REPAIRS OF THE TRANSFORMER	NO.
30.	REPAIRS OF THE TRANSFORMER	NO.
31.	REPAIRS OF THE TRANSFORMER	NO.
32.	REPAIRS OF THE TRANSFORMER	NO.
33.	REPAIRS OF THE TRANSFORMER	NO.
34.	REPAIRS OF THE TRANSFORMER	NO.
35.	REPAIRS OF THE TRANSFORMER	NO.
36.	REPAIRS OF THE TRANSFORMER	NO.
37.	REPAIRS OF THE TRANSFORMER	NO.

**REMARKS:**

1. SPEC ALL DIMENSIONS ARE SUBJECT TO CHECK THE DRAWING.
2. THE CONTRACTOR SHALL BE RESPONSIBLE FOR THE PROTECTION OF THE TRANSFORMER.
3. THE CONTRACTOR SHALL BE RESPONSIBLE FOR THE PROTECTION OF THE TRANSFORMER.
4. THE CONTRACTOR SHALL BE RESPONSIBLE FOR THE PROTECTION OF THE TRANSFORMER.
5. THE CONTRACTOR SHALL BE RESPONSIBLE FOR THE PROTECTION OF THE TRANSFORMER.
6. THE CONTRACTOR SHALL BE RESPONSIBLE FOR THE PROTECTION OF THE TRANSFORMER.
7. THE CONTRACTOR SHALL BE RESPONSIBLE FOR THE PROTECTION OF THE TRANSFORMER.
8. THE CONTRACTOR SHALL BE RESPONSIBLE FOR THE PROTECTION OF THE TRANSFORMER.
9. THE CONTRACTOR SHALL BE RESPONSIBLE FOR THE PROTECTION OF THE TRANSFORMER.
10. THE CONTRACTOR SHALL BE RESPONSIBLE FOR THE PROTECTION OF THE TRANSFORMER.

**NAME OF MANUFACTURE**

\_\_\_\_\_

**DATE** \_\_\_\_\_

**BY** \_\_\_\_\_

**FOR** \_\_\_\_\_



**Technical Specification of 5 MVA and 10 MVA Power Transformer**

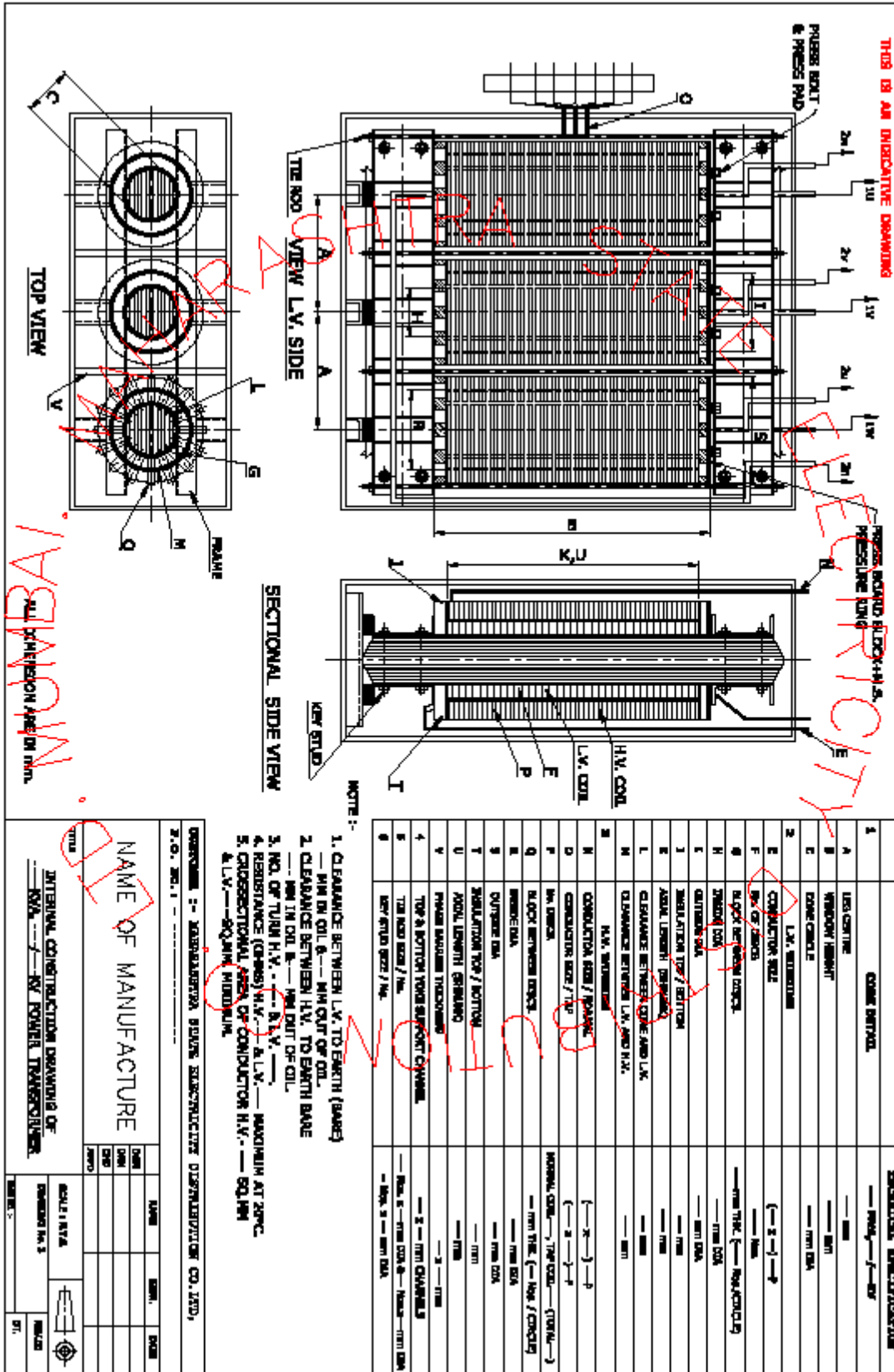

**Technical Specification of 5 MVA and 10 MVA Power Transformer**

TYPE NO.	Q1	Q2	Q3	Q4	Q5	Q6	Q7	Q8	Q9	Q10	Q11	Q12
HEIGHT												
THICK												
WASH												

TOTAL CORE SECTION AREA =  $\text{cm}^2$  \_\_\_\_\_

EFFECTIVE CORE AREA =  $\text{cm}^2$  \_\_\_\_\_

FLUX DENSITY CALCULATION =  $\frac{11000 \times 10^8}{\sqrt{3} \times 6.6 \times 10^3 \times 2} = \text{TESLA}$

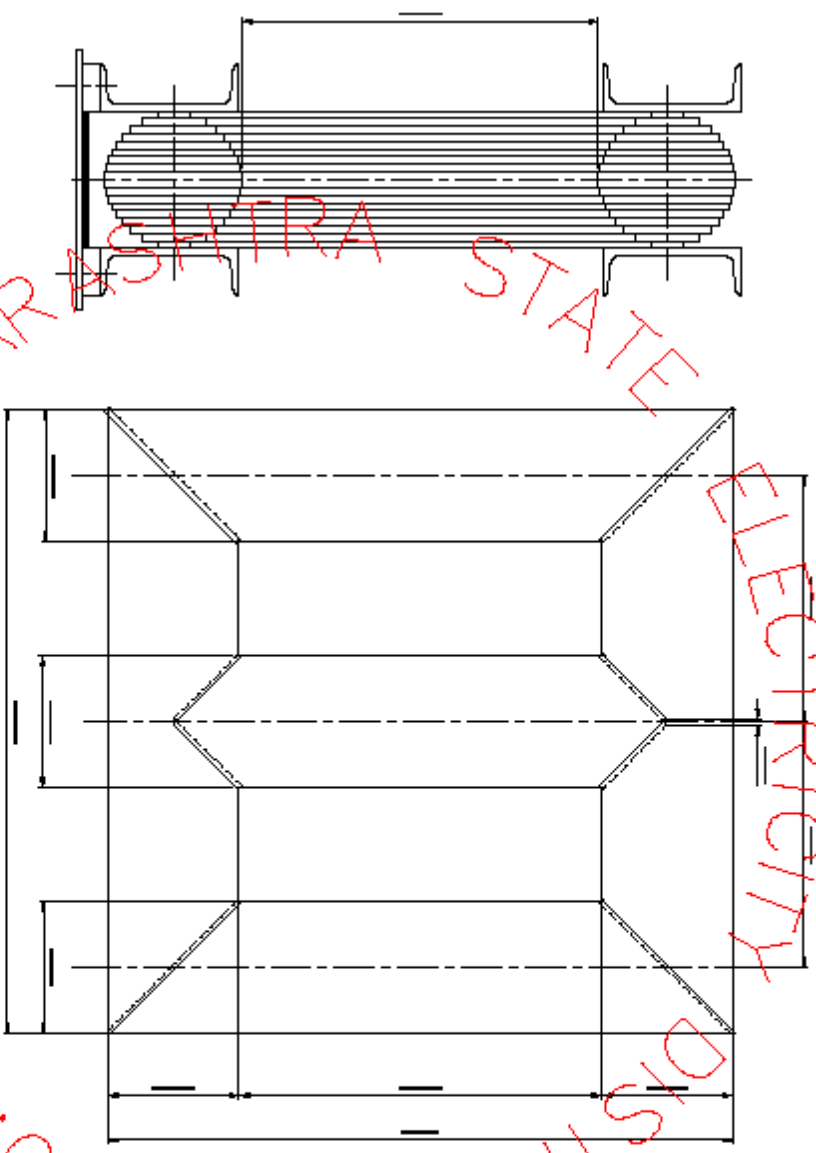

DESIGNER :- MAHARASHTRA STATE ELECTRICITY DISTRIBUTION CO. LTD.,

D.O. NO. 1 - \_\_\_\_\_

NAME OF MANUFACTURE \_\_\_\_\_

DATE \_\_\_\_\_

SCALE \_\_\_\_\_

REVISION No. 4 \_\_\_\_\_

DATE \_\_\_\_\_

ALL DIMENSIONS ARE IN MM.

CORE DIAMETER : ——— MM.  
 WASH, GASKET : ——— MM.  
 L.T. TURNS : ———

**THIS IS AN INDICATIVE DRAWING**

**Technical Specification of 5 MVA and 10 MVA Power Transformer**

Sl. No.	Description	AS SPECIFIED		AS OFFERED EQUIPMENT	
		H.V. Q.L.	L.V. Q.L.	H.V.	L.V.
01	PRIMARY VOLTAGE (KV)	AS SPECIFIED	AS OFFERED		
02	SECONDARY VOLTAGE (KV)				
03	RATING (KVA)				
04	VECTOR GROUP	DYN11	DYN11		
05	PERCENTAGE VOLTAGE REGULATION %	13-2025	13-2025		
06	TEMP. OF TOP OIL (MAX.)°C				
07	TEMP. OF WINDING (MAX.)°C				
08	CORE DETAILS				
09	PROXIMAL SOURCE OF CORE MATERIAL	NOT SPECIFIED			
10	GRADE OF LAMINATION	1.15 MAX.			
11	NO. OF STRIPS	NOT SPECIFIED			
12	% IMPREGNANCE	1-19 VOL.			
13	NO. OF STRIPS	1.15 MAX.			
14	NO. OF STRIPS	NOT SPECIFIED			
15	NO. OF STRIPS	NOT SPECIFIED			
16	NO. OF STRIPS	NOT SPECIFIED			
17	NO. OF STRIPS	NOT SPECIFIED			
18	NO. OF STRIPS	NOT SPECIFIED			
19	NO. OF STRIPS	NOT SPECIFIED			
20	NO. OF STRIPS	NOT SPECIFIED			
21	NO. OF STRIPS	NOT SPECIFIED			
22	NO. OF STRIPS	NOT SPECIFIED			
23	NO. OF STRIPS	NOT SPECIFIED			
24	NO. OF STRIPS	NOT SPECIFIED			
25	NO. OF STRIPS	NOT SPECIFIED			
26	NO. OF STRIPS	NOT SPECIFIED			
27	NO. OF STRIPS	NOT SPECIFIED			
28	NO. OF STRIPS	NOT SPECIFIED			
29	NO. OF STRIPS	NOT SPECIFIED			
30	NO. OF STRIPS	NOT SPECIFIED			
31	NO. OF STRIPS	NOT SPECIFIED			
32	NO. OF STRIPS	NOT SPECIFIED			
33	NO. OF STRIPS	NOT SPECIFIED			
34	NO. OF STRIPS	NOT SPECIFIED			
35	NO. OF STRIPS	NOT SPECIFIED			
36	NO. OF STRIPS	NOT SPECIFIED			
37	NO. OF STRIPS	NOT SPECIFIED			
38	NO. OF STRIPS	NOT SPECIFIED			
39	NO. OF STRIPS	NOT SPECIFIED			
40	NO. OF STRIPS	NOT SPECIFIED			
41	NO. OF STRIPS	NOT SPECIFIED			
42	NO. OF STRIPS	NOT SPECIFIED			
43	NO. OF STRIPS	NOT SPECIFIED			
44	NO. OF STRIPS	NOT SPECIFIED			
45	NO. OF STRIPS	NOT SPECIFIED			
46	NO. OF STRIPS	NOT SPECIFIED			
47	NO. OF STRIPS	NOT SPECIFIED			
48	NO. OF STRIPS	NOT SPECIFIED			
49	NO. OF STRIPS	NOT SPECIFIED			
50	NO. OF STRIPS	NOT SPECIFIED			
51	NO. OF STRIPS	NOT SPECIFIED			
52	NO. OF STRIPS	NOT SPECIFIED			
53	NO. OF STRIPS	NOT SPECIFIED			
54	NO. OF STRIPS	NOT SPECIFIED			
55	NO. OF STRIPS	NOT SPECIFIED			
56	NO. OF STRIPS	NOT SPECIFIED			
57	NO. OF STRIPS	NOT SPECIFIED			
58	NO. OF STRIPS	NOT SPECIFIED			
59	NO. OF STRIPS	NOT SPECIFIED			
60	NO. OF STRIPS	NOT SPECIFIED			
61	NO. OF STRIPS	NOT SPECIFIED			
62	NO. OF STRIPS	NOT SPECIFIED			
63	NO. OF STRIPS	NOT SPECIFIED			
64	NO. OF STRIPS	NOT SPECIFIED			
65	NO. OF STRIPS	NOT SPECIFIED			
66	NO. OF STRIPS	NOT SPECIFIED			
67	NO. OF STRIPS	NOT SPECIFIED			
68	NO. OF STRIPS	NOT SPECIFIED			
69	NO. OF STRIPS	NOT SPECIFIED			
70	NO. OF STRIPS	NOT SPECIFIED			
71	NO. OF STRIPS	NOT SPECIFIED			
72	NO. OF STRIPS	NOT SPECIFIED			
73	NO. OF STRIPS	NOT SPECIFIED			
74	NO. OF STRIPS	NOT SPECIFIED			
75	NO. OF STRIPS	NOT SPECIFIED			
76	NO. OF STRIPS	NOT SPECIFIED			
77	NO. OF STRIPS	NOT SPECIFIED			
78	NO. OF STRIPS	NOT SPECIFIED			
79	NO. OF STRIPS	NOT SPECIFIED			
80	NO. OF STRIPS	NOT SPECIFIED			
81	NO. OF STRIPS	NOT SPECIFIED			
82	NO. OF STRIPS	NOT SPECIFIED			
83	NO. OF STRIPS	NOT SPECIFIED			
84	NO. OF STRIPS	NOT SPECIFIED			
85	NO. OF STRIPS	NOT SPECIFIED			
86	NO. OF STRIPS	NOT SPECIFIED			
87	NO. OF STRIPS	NOT SPECIFIED			
88	NO. OF STRIPS	NOT SPECIFIED			
89	NO. OF STRIPS	NOT SPECIFIED			
90	NO. OF STRIPS	NOT SPECIFIED			
91	NO. OF STRIPS	NOT SPECIFIED			
92	NO. OF STRIPS	NOT SPECIFIED			
93	NO. OF STRIPS	NOT SPECIFIED			
94	NO. OF STRIPS	NOT SPECIFIED			
95	NO. OF STRIPS	NOT SPECIFIED			
96	NO. OF STRIPS	NOT SPECIFIED			
97	NO. OF STRIPS	NOT SPECIFIED			
98	NO. OF STRIPS	NOT SPECIFIED			
99	NO. OF STRIPS	NOT SPECIFIED			
100	NO. OF STRIPS	NOT SPECIFIED			

THIS IS AN INDICATIVE DRAWING

MAHARASHTRA

ELECTRICITY

NOTION

**ALL DIMENSIONS ARE IN MM.**

COMPOUND - 1 - MAHARASHTRA STATE ELECTRICITY DISTRIBUTION CO. LTD.,  
P.O. NO. 1 -

NAME OF MANUFACTURE

TECHNICAL DETAILS OF  
KVA, / /

SCALE: 1:10

DATE

BY

DATE

**Technical Specification of 5 MVA and 10 MVA Power Transformer**

M16x80 BOLT & M-40 HEXNUT & WAS. AT 140mm P.C.D.

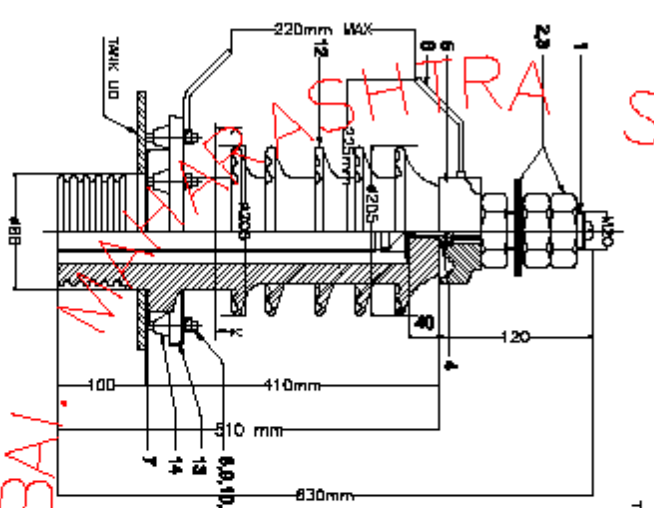

SECTION AT XX

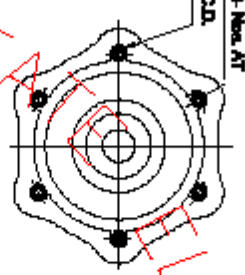

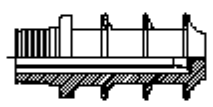

TOTAL CLEARANCE DISTANCE= 500mm

NO.	DESCRIPTION	QTY
1	Hex Nut, M16x80	
2	Hex Bolt, M16x80	
3	Hex Washer, 140mm P.C.D.	
4	Bushing	1
5	Hex Bolt, M16x80	
6	Hex Nut, M16x80	
7	Hex Washer, 140mm P.C.D.	
8	Bushing	1
9	Hex Bolt, M16x80	
10	Hex Nut, M16x80	
11	Hex Washer, 140mm P.C.D.	
12	Bushing	1
13	Hex Bolt, M16x80	
14	Hex Nut, M16x80	
15	Hex Washer, 140mm P.C.D.	
16	Bushing	1

**BUSHING CHARACTERISTICS**  
 Name: \_\_\_\_\_  
 No. Type: \_\_\_\_\_

No. of turns: \_\_\_\_\_  
 No. of layers: \_\_\_\_\_  
 No. of inter-layers: \_\_\_\_\_  
 No. of inter-turns: \_\_\_\_\_  
 No. of layers: \_\_\_\_\_  
 No. of inter-layers: \_\_\_\_\_  
 No. of inter-turns: \_\_\_\_\_  
 No. of layers: \_\_\_\_\_  
 No. of inter-layers: \_\_\_\_\_  
 No. of inter-turns: \_\_\_\_\_

NOTE: ALL DIMENSIONS ARE IN mm.  
 ALL DIMENSIONS ARE IN mm.

ALL DIMENSIONS ARE IN mm.

NAME OF MANUFACTURE: \_\_\_\_\_

DATE	DATE
BY	BY
CHKD	CHKD
APPD	APPD

SCALE: N.T.S.	
DRAWING NO.:	
REVISED	BY:
DT.	

THIS IS AN INDICATIVE DRAWING

MAHAVITARA

MUMBAI

0.0

DISK

MAHAVITARA ELECTRICITY DISTRIBUTION

### Technical Specification of 5 MVA and 10 MVA Power Transformer

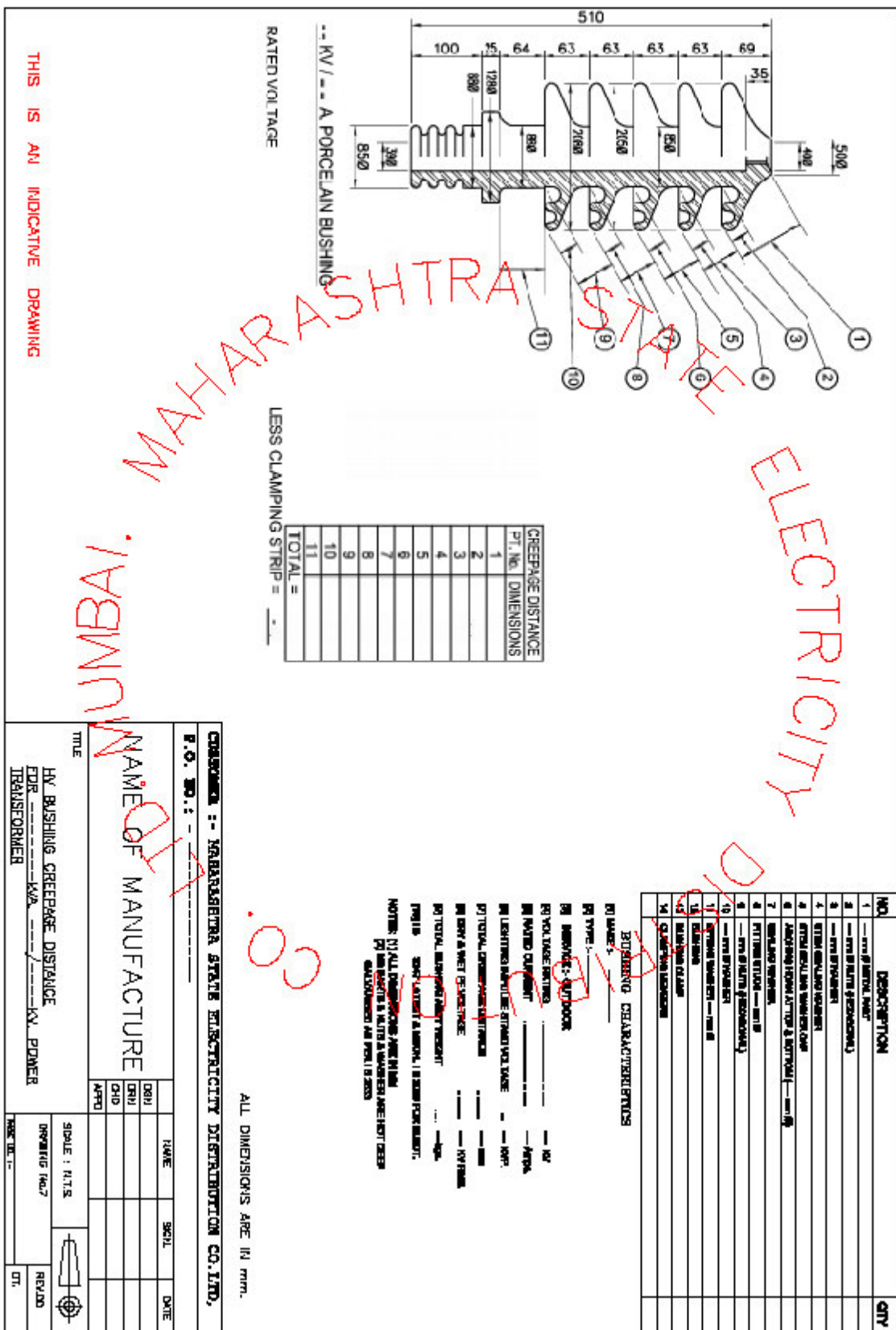



**Technical Specification of 5 MVA and 10 MVA Power Transformer**

THIS IS AN INDICATIVE DRAWING

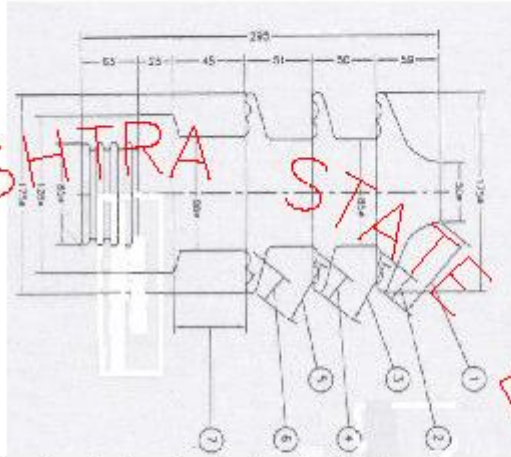

PT. NO.	DIMENSIONS
1	
2	
3	
4	
5	
6	
7	
TOTAL =	-----

MAHARASHTRA STATE ELECTRICITY

NO.	DESCRIPTION	QTY
1	--- mm dia. METAL BUSH	
2	--- mm dia. METAL BUSH	
3	--- mm dia. METAL BUSH	
4	--- mm dia. METAL BUSH	
5	--- mm dia. METAL BUSH	
6	--- mm dia. METAL BUSH	
7	--- mm dia. METAL BUSH	
8	--- mm dia. METAL BUSH	
9	--- mm dia. METAL BUSH	
10	--- mm dia. METAL BUSH	
11	--- mm dia. METAL BUSH	
12	--- mm dia. METAL BUSH	
13	--- mm dia. METAL BUSH	
14	--- mm dia. METAL BUSH	
15	--- mm dia. METAL BUSH	
16	--- mm dia. METAL BUSH	
17	--- mm dia. METAL BUSH	
18	--- mm dia. METAL BUSH	
19	--- mm dia. METAL BUSH	
20	--- mm dia. METAL BUSH	
21	--- mm dia. METAL BUSH	
22	--- mm dia. METAL BUSH	
23	--- mm dia. METAL BUSH	
24	--- mm dia. METAL BUSH	
25	--- mm dia. METAL BUSH	
26	--- mm dia. METAL BUSH	
27	--- mm dia. METAL BUSH	
28	--- mm dia. METAL BUSH	
29	--- mm dia. METAL BUSH	
30	--- mm dia. METAL BUSH	
31	--- mm dia. METAL BUSH	
32	--- mm dia. METAL BUSH	
33	--- mm dia. METAL BUSH	
34	--- mm dia. METAL BUSH	
35	--- mm dia. METAL BUSH	
36	--- mm dia. METAL BUSH	
37	--- mm dia. METAL BUSH	
38	--- mm dia. METAL BUSH	
39	--- mm dia. METAL BUSH	
40	--- mm dia. METAL BUSH	
41	--- mm dia. METAL BUSH	
42	--- mm dia. METAL BUSH	
43	--- mm dia. METAL BUSH	
44	--- mm dia. METAL BUSH	
45	--- mm dia. METAL BUSH	
46	--- mm dia. METAL BUSH	
47	--- mm dia. METAL BUSH	
48	--- mm dia. METAL BUSH	
49	--- mm dia. METAL BUSH	
50	--- mm dia. METAL BUSH	
51	--- mm dia. METAL BUSH	
52	--- mm dia. METAL BUSH	
53	--- mm dia. METAL BUSH	
54	--- mm dia. METAL BUSH	
55	--- mm dia. METAL BUSH	
56	--- mm dia. METAL BUSH	
57	--- mm dia. METAL BUSH	
58	--- mm dia. METAL BUSH	
59	--- mm dia. METAL BUSH	
60	--- mm dia. METAL BUSH	
61	--- mm dia. METAL BUSH	
62	--- mm dia. METAL BUSH	
63	--- mm dia. METAL BUSH	
64	--- mm dia. METAL BUSH	
65	--- mm dia. METAL BUSH	
66	--- mm dia. METAL BUSH	
67	--- mm dia. METAL BUSH	
68	--- mm dia. METAL BUSH	
69	--- mm dia. METAL BUSH	
70	--- mm dia. METAL BUSH	
71	--- mm dia. METAL BUSH	
72	--- mm dia. METAL BUSH	
73	--- mm dia. METAL BUSH	
74	--- mm dia. METAL BUSH	
75	--- mm dia. METAL BUSH	
76	--- mm dia. METAL BUSH	
77	--- mm dia. METAL BUSH	
78	--- mm dia. METAL BUSH	
79	--- mm dia. METAL BUSH	
80	--- mm dia. METAL BUSH	
81	--- mm dia. METAL BUSH	
82	--- mm dia. METAL BUSH	
83	--- mm dia. METAL BUSH	
84	--- mm dia. METAL BUSH	
85	--- mm dia. METAL BUSH	
86	--- mm dia. METAL BUSH	
87	--- mm dia. METAL BUSH	
88	--- mm dia. METAL BUSH	
89	--- mm dia. METAL BUSH	
90	--- mm dia. METAL BUSH	
91	--- mm dia. METAL BUSH	
92	--- mm dia. METAL BUSH	
93	--- mm dia. METAL BUSH	
94	--- mm dia. METAL BUSH	
95	--- mm dia. METAL BUSH	
96	--- mm dia. METAL BUSH	
97	--- mm dia. METAL BUSH	
98	--- mm dia. METAL BUSH	
99	--- mm dia. METAL BUSH	
100	--- mm dia. METAL BUSH	

**BUSBARS - DIMENSIONS**

Material: --- mm dia. METAL BUSH

Finish: --- mm dia. METAL BUSH

Dimensions: --- mm dia. METAL BUSH

Notes: --- mm dia. METAL BUSH

**CONTRACT NO. :- MAHARASHTRA STATE ELECTRICITY DISTRIBUTION CO. LTD,**

**P.O. NO. :-**

**NAME OF MANUFACTURE**

**TITLE**

LV BUSHING CREEPAGE DISTANCE

FOR --- kVA --- KV POWER

TRANSFORMER

DATE	BY	CHKD	APPD

SCALE : 1:1

DRAWING NO. 08

REVISED

DT.

ALL DIMENSIONS ARE IN mm.

**Technical Specification of 5 MVA and 10 MVA Power Transformer**

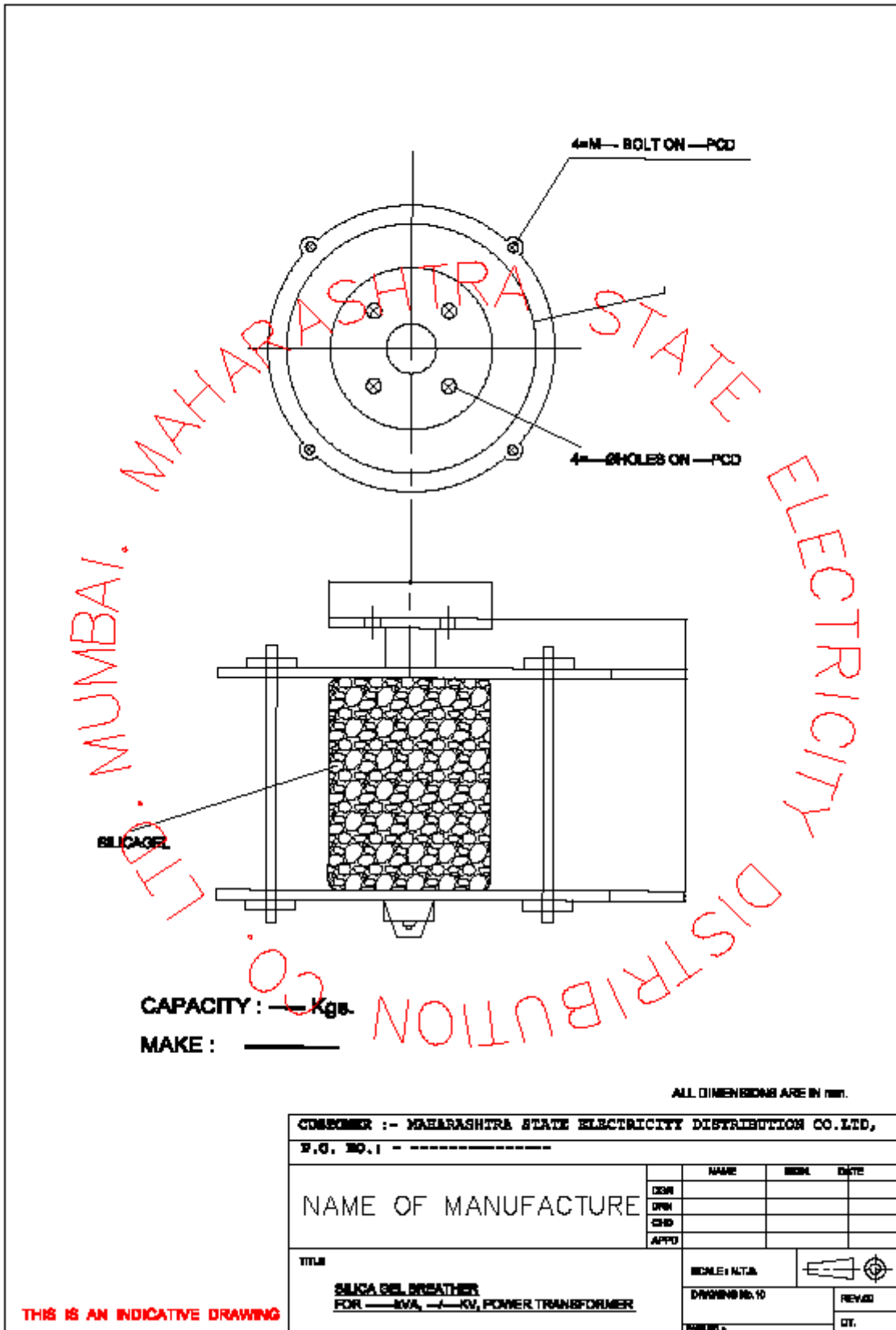



**Technical Specification of 5 MVA and 10 MVA Power Transformer**

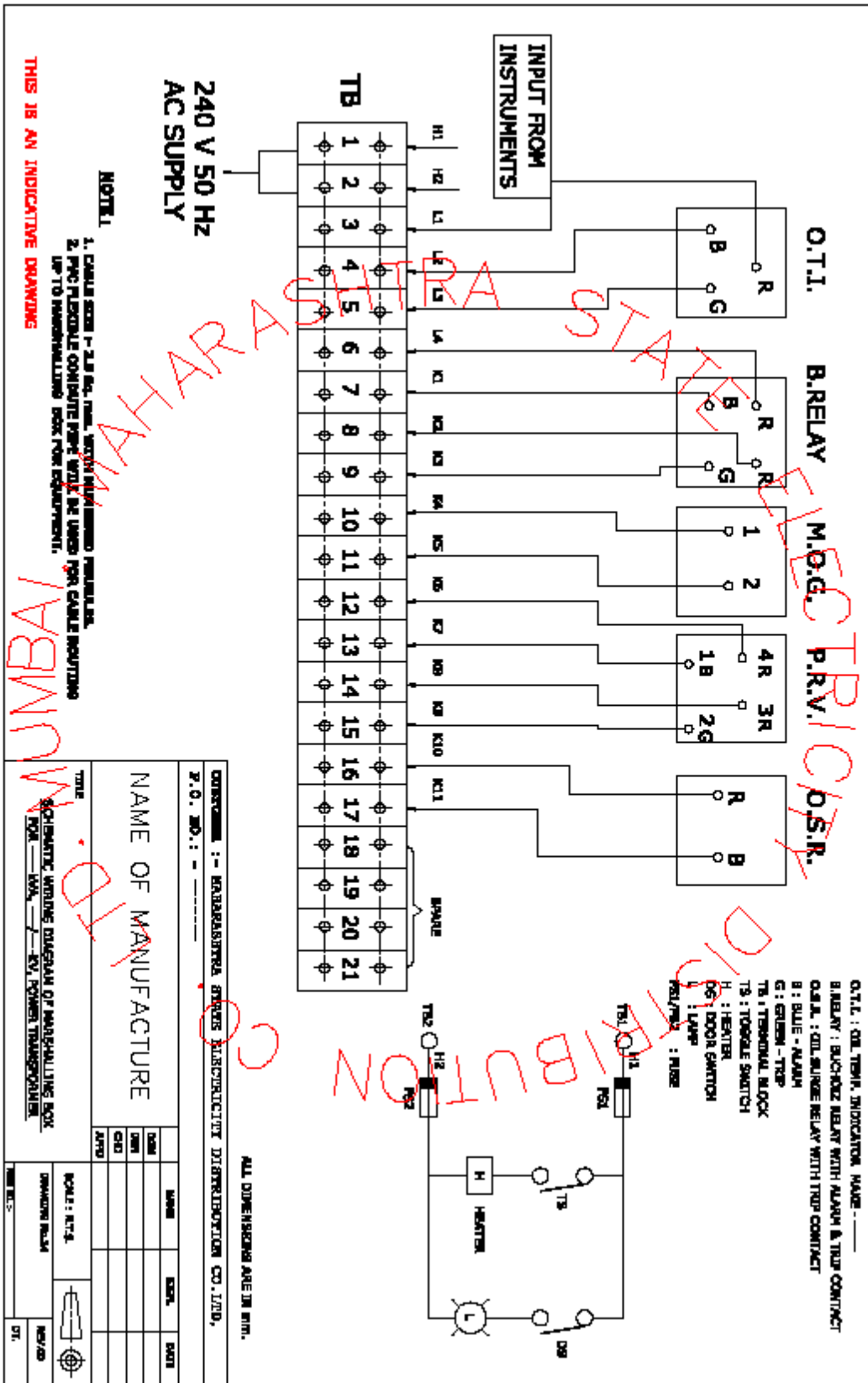

**Technical Specification of 5 MVA and 10 MVA Power Transformer**

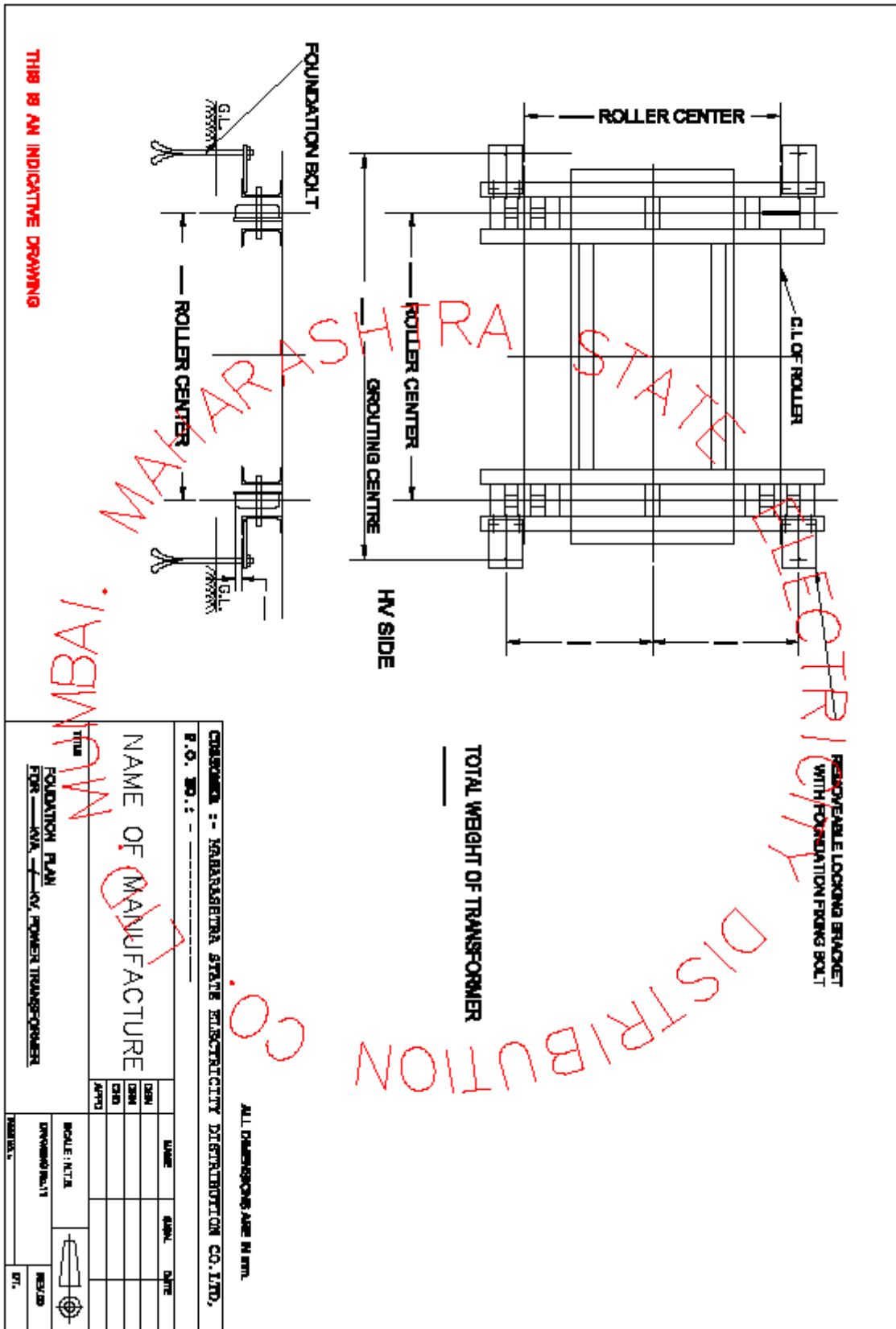

**THIS IS AN INDICATIVE DRAWING**

**Technical Specification of 5 MVA and 10 MVA Power Transformer**

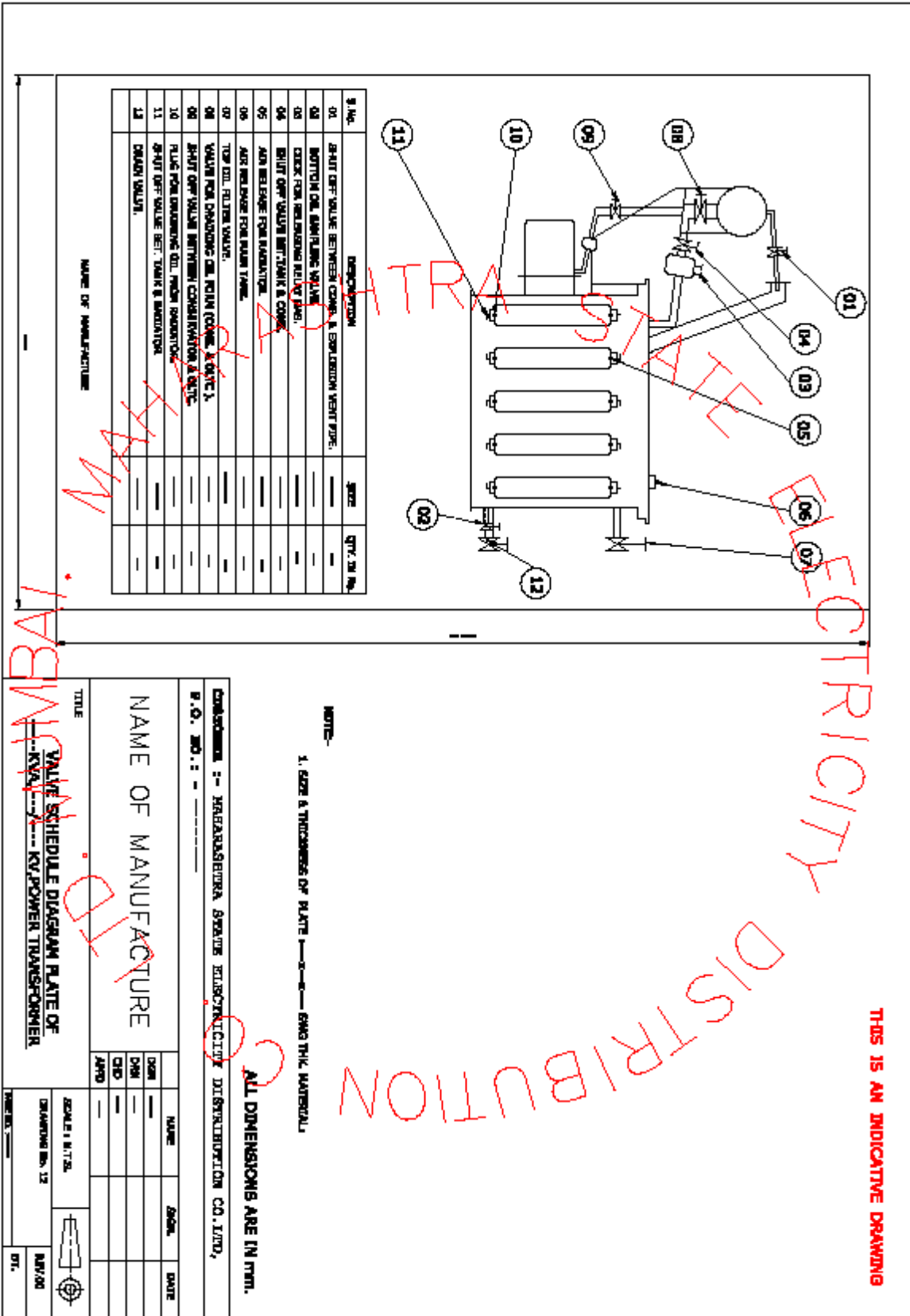

NOTE:-

1. SIZE & THICKNESS OF PLATE ———— 6MM THICK MATERIAL.

ALL DIMENSIONS ARE IN MM.

CONSUMER :- MAHARASHTRA STATE ELECTRICITY DISTRIBUTION CO. LTD.,

P.O. NO. :-

NAME OF MANUFACTURE

NAME	DESIGN	DATE
DESIGNER		
CHECKED		
APPROVED		

TITLE

VALVE SCHEDULE DIAGRAM PLATE OF  
5 MVA / 10 MVA KV POWER TRANSFORMER

SCALE 1:1	DATE
DRAWING NO. 12	REV/00
DATE	DT.

THIS IS AN INDICATIVE DRAWING

**Technical Specification of 5 MVA and 10 MVA Power Transformer**

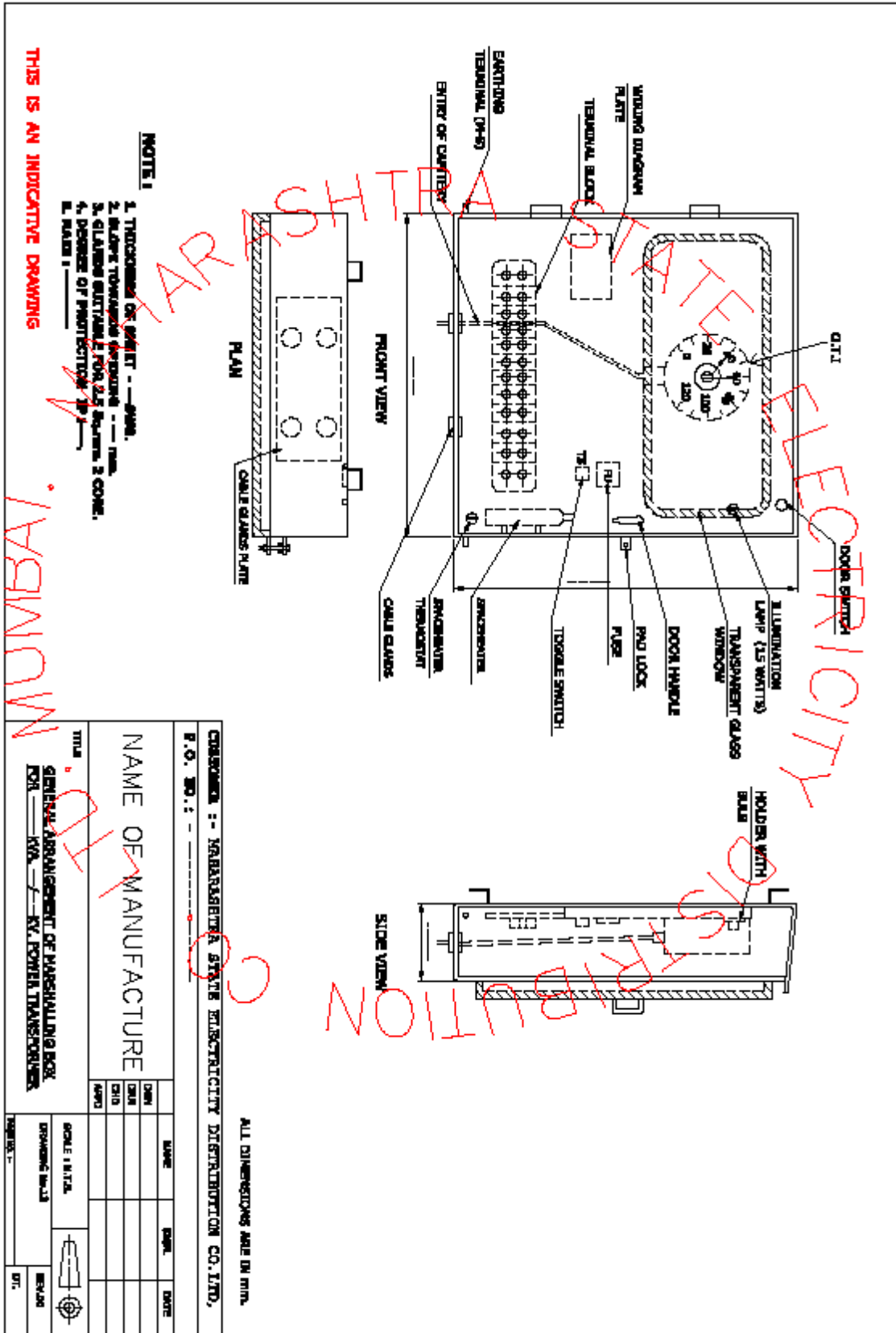

**MAHARASHTRA STATE ELECTRICITY DISTRIBUTION CO. LTD.**

**ALL DIMENSIONS ARE IN MM.**

**CONSUMER :- MAHARASHTRA STATE ELECTRICITY DISTRIBUTION CO. LTD.**

**P. O. NO. :-**

**NAME OF MANUFACTURE**

DATE	NAME	DATE

**TITLE** GENERAL ARRANGEMENT OF MOUNTING BOX FOR 5 MVA AND 10 MVA POWER TRANSFORMER

**SCALE 1:1**

**DRAWING NO. 13**

**DATE**

**BY**

**CHK**

**APP**

**REVISION**

**DT.**

**Technical Specification of 5 MVA and 10 MVA Power Transformer**

CTR

ON LOAD TAPCHANGER

LICENCE: ENGLISH ELECTRIC, ENGLAND.

TYPE  S.N.  YEAR

CTR O.A.N.C.  CUSTOMER W.O.N.C.

MOTOR  V  50 HZ CONTROL  V  50 HZ

SERVICE VOLTAGE  KV NORMAL WORKING CURRENT  A

MAX. RATED THROUGH CURRENT  A

PHASES  3 FREQUENCY  50 HZ STEPS  STEP VOLTAGE  V

WEIGHTS/VOLUME

TAPCHANGER WITHOUT OIL  Kg

OIL  Kg LITRES TOTAL  Kg

THIS TAPCHANGER IS SUITABLE FOR DIRECTION OF POWERFLOW TO THE EXTENT SHOWN BELOW.

HV TO LV  % LV TO HV  %

MAKERS: **EEI** MANUFACTURING INDUSTRIES LIMITED. IS:8468

POONA 411014 INDIA.

DISTRIBUTION CO.

MUMBAI. MAHARASHTRA

CONTRACT :- **MAHARASHTRA STATE ELECTRICITY DISTRIBUTION CO. LTD.**

F.O. NO. :-

NAME OF MANUFACTURE

DATE	SCALE	DATE

SCALE: N.T.S.

DRAWING NO. 13 REVISED

DATE:  DT.

ALL DIMENSIONS ARE IN mm.

THIS IS AN INDICATIVE DRAWING

**Technical Specification of 5 MVA and 10 MVA Power Transformer**

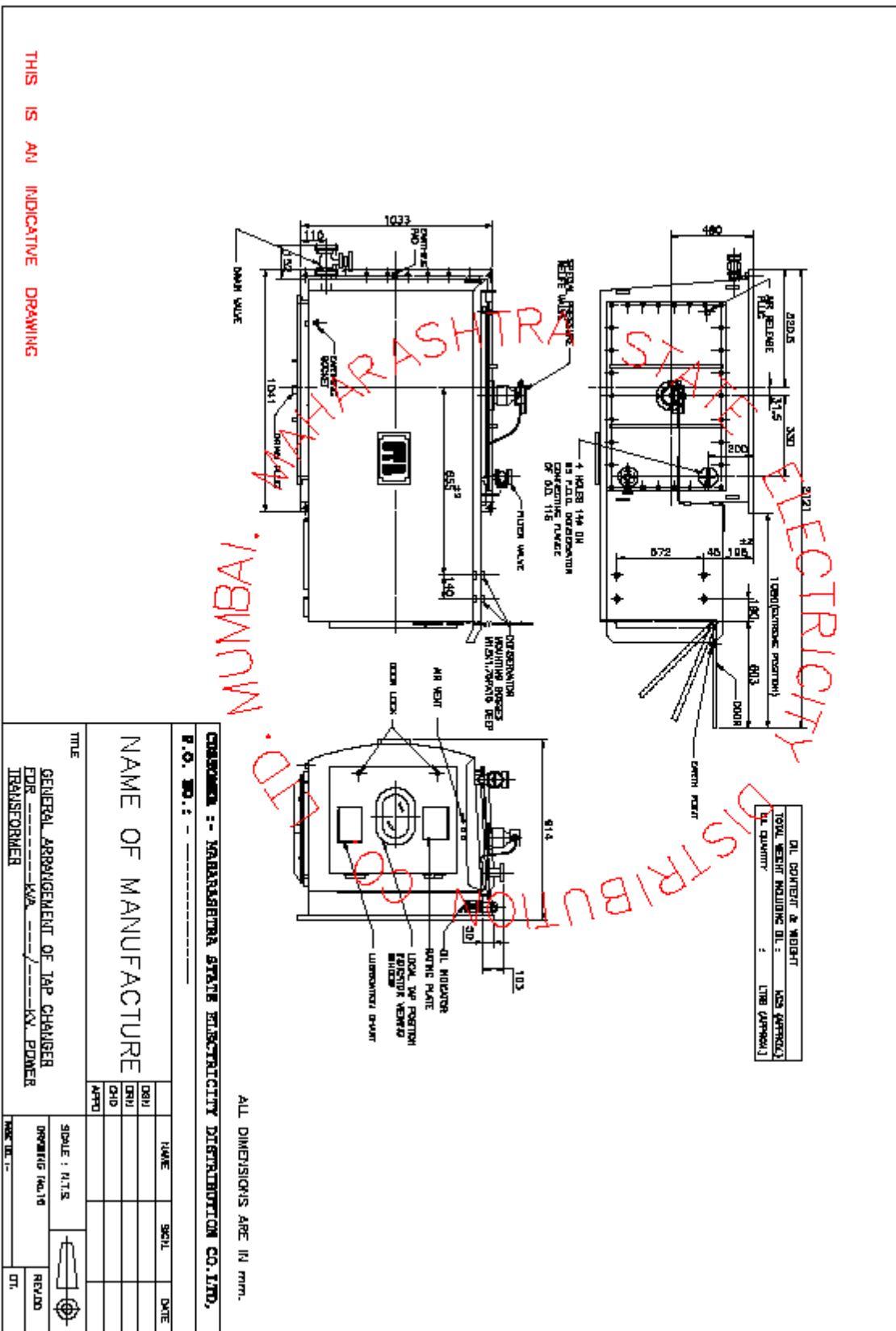

**Oil Content & Weight Table:**

OIL CONTENT & WEIGHT	KG (APPROX)
TOTAL WEIGHT INCLUDING OIL :	178 (APPROX)
Oil Quantity :	

**Title Block:**

**TITLE**  
GENERAL ARRANGEMENT OF TAP CHANGER FOR      KVA      KV POWER TRANSFORMER

**NAME OF MANUFACTURE**

**DESIGNER** \_\_\_\_\_ **DATE** \_\_\_\_\_

**CHECKER** \_\_\_\_\_ **SCALE** \_\_\_\_\_ **DATE** \_\_\_\_\_

**APPROVED** \_\_\_\_\_

**SCALE : N.T.S.**

**DRAWING No. / 10**

**REVISED** \_\_\_\_\_

**DATE** \_\_\_\_\_

THIS IS AN INDICATIVE DRAWING

MUMBAI. MAHARASHTRA. ELECTRICITY DISTRIBUTION CO. LTD.

ALL DIMENSIONS ARE IN mm.

**Technical Specification of 5 MVA and 10 MVA Power Transformer**

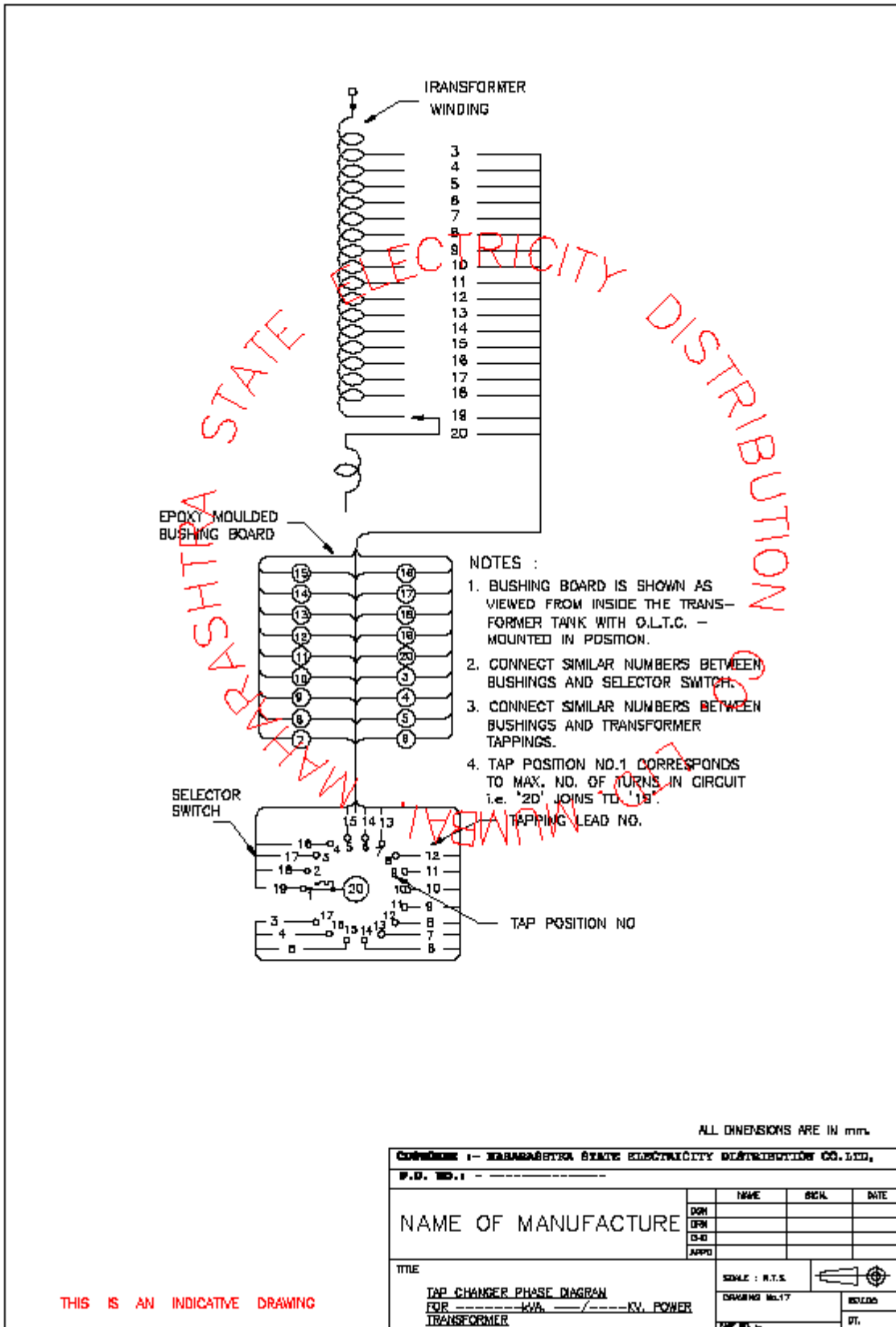

ALL DIMENSIONS ARE IN mm.

Copyright © - MAHARASHTRA STATE ELECTRICITY DISTRIBUTION CO. LTD.,  
 P.O. NO. 1 - - - - -

NAME OF MANUFACTURE	DRN	NAME	SCALE	DATE
	DFM			
	ESD			
	APPO			

TITLE

TAP CHANGER PHASE DIAGRAM  
 FOR -----KVA. /-----KV. POWER  
 TRANSFORMER

SCALE : N.T.S. 

DRAWING No. 17

TAK No. -

ESLDO

DT.

THIS IS AN INDICATIVE DRAWING

**Technical Specification of 5 MVA and 10 MVA Power Transformer**

THIS IS AN INDICATIVE DRAWING

⊗ INDICATES INTER-CONNECTION BETWEEN DLTZ-A & RTOZ  
⊙ INDICATES INTER-CONNECTION BETWEEN TWO DLTZ'S

- NOTES**
1. NAME AND LOWER NUMBER TO THE NUMBERS.
  2. ALL EQUIPMENT IS IN NORMAL CONTROL TAP CHANGERS SCHEME AT THE 10% & 110% TAPS READY FOR ACTIVATED A TAP CHANGE MANUALLY OR ELECTRICALLY.
  3. TAP CHANGERS SHALL BE OF THE SAME TAP POSITION.
  4. CORRECT PHASE SEQUENCE R-Y-B IS ESSENTIAL FOR CONNECTIONS. TERMINALS PHASE SHALL BE IDENTIFIED BY TO INDICATE RITE SEQUENCE TO THE POSITION FOR THE CORRECT CONNECTION. THE POSITION OF THE TAP CHANGER SHALL BE IDENTIFIED BY THE POSITION OF THE TAP CHANGER. THE POSITION OF THE TAP CHANGER SHALL BE IDENTIFIED BY THE POSITION OF THE TAP CHANGER.
  5. WHEN THE TAP CHANGER IS IN THE POSITION OF THE TAP CHANGER, THE POSITION OF THE TAP CHANGER SHALL BE IDENTIFIED BY THE POSITION OF THE TAP CHANGER.
  6. THE POSITION OF THE TAP CHANGER SHALL BE IDENTIFIED BY THE POSITION OF THE TAP CHANGER.
  7. THE POSITION OF THE TAP CHANGER SHALL BE IDENTIFIED BY THE POSITION OF THE TAP CHANGER.
  8. THE POSITION OF THE TAP CHANGER SHALL BE IDENTIFIED BY THE POSITION OF THE TAP CHANGER.

**ELECTRICAL**

**KEY TO DIAGRAM**

NO.	DESCRIPTION
1	GROUP CONTROL OF TAP CHANGER
2	GROUP CONTROL OF TAP CHANGER
3	GROUP CONTROL OF TAP CHANGER
4	GROUP CONTROL OF TAP CHANGER
5	GROUP CONTROL OF TAP CHANGER
6	GROUP CONTROL OF TAP CHANGER
7	GROUP CONTROL OF TAP CHANGER
8	GROUP CONTROL OF TAP CHANGER
9	GROUP CONTROL OF TAP CHANGER
10	GROUP CONTROL OF TAP CHANGER
11	GROUP CONTROL OF TAP CHANGER
12	GROUP CONTROL OF TAP CHANGER
13	GROUP CONTROL OF TAP CHANGER
14	GROUP CONTROL OF TAP CHANGER
15	GROUP CONTROL OF TAP CHANGER
16	GROUP CONTROL OF TAP CHANGER
17	GROUP CONTROL OF TAP CHANGER
18	GROUP CONTROL OF TAP CHANGER
19	GROUP CONTROL OF TAP CHANGER
20	GROUP CONTROL OF TAP CHANGER
21	GROUP CONTROL OF TAP CHANGER
22	GROUP CONTROL OF TAP CHANGER
23	GROUP CONTROL OF TAP CHANGER
24	GROUP CONTROL OF TAP CHANGER
25	GROUP CONTROL OF TAP CHANGER
26	GROUP CONTROL OF TAP CHANGER
27	GROUP CONTROL OF TAP CHANGER
28	GROUP CONTROL OF TAP CHANGER
29	GROUP CONTROL OF TAP CHANGER
30	GROUP CONTROL OF TAP CHANGER
31	GROUP CONTROL OF TAP CHANGER
32	GROUP CONTROL OF TAP CHANGER
33	GROUP CONTROL OF TAP CHANGER
34	GROUP CONTROL OF TAP CHANGER
35	GROUP CONTROL OF TAP CHANGER
36	GROUP CONTROL OF TAP CHANGER
37	GROUP CONTROL OF TAP CHANGER
38	GROUP CONTROL OF TAP CHANGER
39	GROUP CONTROL OF TAP CHANGER
40	GROUP CONTROL OF TAP CHANGER
41	GROUP CONTROL OF TAP CHANGER
42	GROUP CONTROL OF TAP CHANGER
43	GROUP CONTROL OF TAP CHANGER
44	GROUP CONTROL OF TAP CHANGER
45	GROUP CONTROL OF TAP CHANGER
46	GROUP CONTROL OF TAP CHANGER
47	GROUP CONTROL OF TAP CHANGER
48	GROUP CONTROL OF TAP CHANGER
49	GROUP CONTROL OF TAP CHANGER
50	GROUP CONTROL OF TAP CHANGER
51	GROUP CONTROL OF TAP CHANGER
52	GROUP CONTROL OF TAP CHANGER
53	GROUP CONTROL OF TAP CHANGER
54	GROUP CONTROL OF TAP CHANGER
55	GROUP CONTROL OF TAP CHANGER
56	GROUP CONTROL OF TAP CHANGER
57	GROUP CONTROL OF TAP CHANGER
58	GROUP CONTROL OF TAP CHANGER
59	GROUP CONTROL OF TAP CHANGER
60	GROUP CONTROL OF TAP CHANGER
61	GROUP CONTROL OF TAP CHANGER
62	GROUP CONTROL OF TAP CHANGER
63	GROUP CONTROL OF TAP CHANGER
64	GROUP CONTROL OF TAP CHANGER
65	GROUP CONTROL OF TAP CHANGER
66	GROUP CONTROL OF TAP CHANGER
67	GROUP CONTROL OF TAP CHANGER
68	GROUP CONTROL OF TAP CHANGER
69	GROUP CONTROL OF TAP CHANGER
70	GROUP CONTROL OF TAP CHANGER
71	GROUP CONTROL OF TAP CHANGER
72	GROUP CONTROL OF TAP CHANGER
73	GROUP CONTROL OF TAP CHANGER
74	GROUP CONTROL OF TAP CHANGER
75	GROUP CONTROL OF TAP CHANGER
76	GROUP CONTROL OF TAP CHANGER
77	GROUP CONTROL OF TAP CHANGER
78	GROUP CONTROL OF TAP CHANGER
79	GROUP CONTROL OF TAP CHANGER
80	GROUP CONTROL OF TAP CHANGER
81	GROUP CONTROL OF TAP CHANGER
82	GROUP CONTROL OF TAP CHANGER
83	GROUP CONTROL OF TAP CHANGER
84	GROUP CONTROL OF TAP CHANGER
85	GROUP CONTROL OF TAP CHANGER
86	GROUP CONTROL OF TAP CHANGER
87	GROUP CONTROL OF TAP CHANGER
88	GROUP CONTROL OF TAP CHANGER
89	GROUP CONTROL OF TAP CHANGER
90	GROUP CONTROL OF TAP CHANGER
91	GROUP CONTROL OF TAP CHANGER
92	GROUP CONTROL OF TAP CHANGER
93	GROUP CONTROL OF TAP CHANGER
94	GROUP CONTROL OF TAP CHANGER
95	GROUP CONTROL OF TAP CHANGER
96	GROUP CONTROL OF TAP CHANGER
97	GROUP CONTROL OF TAP CHANGER
98	GROUP CONTROL OF TAP CHANGER
99	GROUP CONTROL OF TAP CHANGER
100	GROUP CONTROL OF TAP CHANGER

LOCATION	REMARKS
1	GROUP CONTROL OF TAP CHANGER
2	GROUP CONTROL OF TAP CHANGER
3	GROUP CONTROL OF TAP CHANGER
4	GROUP CONTROL OF TAP CHANGER
5	GROUP CONTROL OF TAP CHANGER
6	GROUP CONTROL OF TAP CHANGER
7	GROUP CONTROL OF TAP CHANGER
8	GROUP CONTROL OF TAP CHANGER
9	GROUP CONTROL OF TAP CHANGER
10	GROUP CONTROL OF TAP CHANGER
11	GROUP CONTROL OF TAP CHANGER
12	GROUP CONTROL OF TAP CHANGER
13	GROUP CONTROL OF TAP CHANGER
14	GROUP CONTROL OF TAP CHANGER
15	GROUP CONTROL OF TAP CHANGER
16	GROUP CONTROL OF TAP CHANGER
17	GROUP CONTROL OF TAP CHANGER
18	GROUP CONTROL OF TAP CHANGER
19	GROUP CONTROL OF TAP CHANGER
20	GROUP CONTROL OF TAP CHANGER
21	GROUP CONTROL OF TAP CHANGER
22	GROUP CONTROL OF TAP CHANGER
23	GROUP CONTROL OF TAP CHANGER
24	GROUP CONTROL OF TAP CHANGER
25	GROUP CONTROL OF TAP CHANGER
26	GROUP CONTROL OF TAP CHANGER
27	GROUP CONTROL OF TAP CHANGER
28	GROUP CONTROL OF TAP CHANGER
29	GROUP CONTROL OF TAP CHANGER
30	GROUP CONTROL OF TAP CHANGER
31	GROUP CONTROL OF TAP CHANGER
32	GROUP CONTROL OF TAP CHANGER
33	GROUP CONTROL OF TAP CHANGER
34	GROUP CONTROL OF TAP CHANGER
35	GROUP CONTROL OF TAP CHANGER
36	GROUP CONTROL OF TAP CHANGER
37	GROUP CONTROL OF TAP CHANGER
38	GROUP CONTROL OF TAP CHANGER
39	GROUP CONTROL OF TAP CHANGER
40	GROUP CONTROL OF TAP CHANGER
41	GROUP CONTROL OF TAP CHANGER
42	GROUP CONTROL OF TAP CHANGER
43	GROUP CONTROL OF TAP CHANGER
44	GROUP CONTROL OF TAP CHANGER
45	GROUP CONTROL OF TAP CHANGER
46	GROUP CONTROL OF TAP CHANGER
47	GROUP CONTROL OF TAP CHANGER
48	GROUP CONTROL OF TAP CHANGER
49	GROUP CONTROL OF TAP CHANGER
50	GROUP CONTROL OF TAP CHANGER
51	GROUP CONTROL OF TAP CHANGER
52	GROUP CONTROL OF TAP CHANGER
53	GROUP CONTROL OF TAP CHANGER
54	GROUP CONTROL OF TAP CHANGER
55	GROUP CONTROL OF TAP CHANGER
56	GROUP CONTROL OF TAP CHANGER
57	GROUP CONTROL OF TAP CHANGER
58	GROUP CONTROL OF TAP CHANGER
59	GROUP CONTROL OF TAP CHANGER
60	GROUP CONTROL OF TAP CHANGER
61	GROUP CONTROL OF TAP CHANGER
62	GROUP CONTROL OF TAP CHANGER
63	GROUP CONTROL OF TAP CHANGER
64	GROUP CONTROL OF TAP CHANGER
65	GROUP CONTROL OF TAP CHANGER
66	GROUP CONTROL OF TAP CHANGER
67	GROUP CONTROL OF TAP CHANGER
68	GROUP CONTROL OF TAP CHANGER
69	GROUP CONTROL OF TAP CHANGER
70	GROUP CONTROL OF TAP CHANGER
71	GROUP CONTROL OF TAP CHANGER
72	GROUP CONTROL OF TAP CHANGER
73	GROUP CONTROL OF TAP CHANGER
74	GROUP CONTROL OF TAP CHANGER
75	GROUP CONTROL OF TAP CHANGER
76	GROUP CONTROL OF TAP CHANGER
77	GROUP CONTROL OF TAP CHANGER
78	GROUP CONTROL OF TAP CHANGER
79	GROUP CONTROL OF TAP CHANGER
80	GROUP CONTROL OF TAP CHANGER
81	GROUP CONTROL OF TAP CHANGER
82	GROUP CONTROL OF TAP CHANGER
83	GROUP CONTROL OF TAP CHANGER
84	GROUP CONTROL OF TAP CHANGER
85	GROUP CONTROL OF TAP CHANGER
86	GROUP CONTROL OF TAP CHANGER
87	GROUP CONTROL OF TAP CHANGER
88	GROUP CONTROL OF TAP CHANGER
89	GROUP CONTROL OF TAP CHANGER
90	GROUP CONTROL OF TAP CHANGER
91	GROUP CONTROL OF TAP CHANGER
92	GROUP CONTROL OF TAP CHANGER
93	GROUP CONTROL OF TAP CHANGER
94	GROUP CONTROL OF TAP CHANGER
95	GROUP CONTROL OF TAP CHANGER
96	GROUP CONTROL OF TAP CHANGER
97	GROUP CONTROL OF TAP CHANGER
98	GROUP CONTROL OF TAP CHANGER
99	GROUP CONTROL OF TAP CHANGER
100	GROUP CONTROL OF TAP CHANGER

**MAHARASHTRA**  
**MUMBAI.**

ALL DIMENSIONS ARE IN mm.

**CONSUMER :- MAHARASHTRA STATE ELECTRICITY DISTRIBUTION CO. LTD,**

**P.O. NO. :-**

**NAME OF MANUFACTURE**

DATE	SCALE	DATE
DRN		
CRN		
CND		
APPD		

**TITLE**

**GROUP CONTROL OF TAP CHARGE GEAR FOR ---KV---KV POWER TRANSFORMER**

**SCALE : R.T.S**

**DRAWING NO. 18**

**REVISED**

**DT.**



**Technical Specification of 5 MVA and 10 MVA Power Transformer**

THIS IS AN INDICATIVE DRAWING

UNIT B  
SHOWN SET AS FOLLOWS

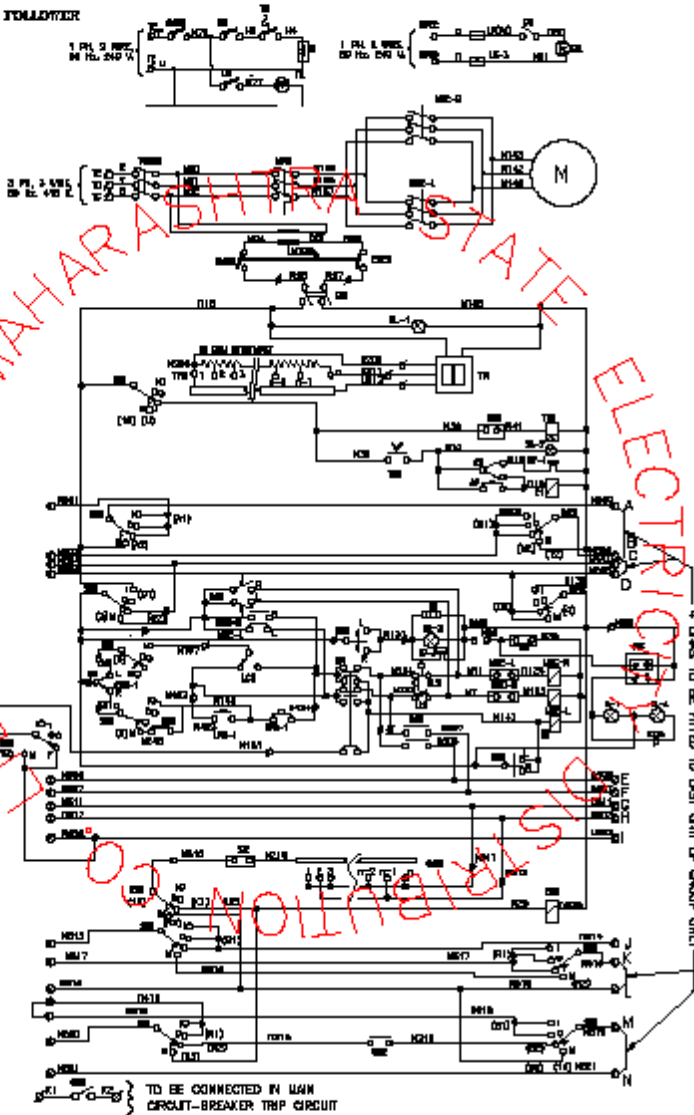

ALL DIMENSIONS ARE IN mm.

<p><b>CHANGING :- MAHARASHTRA STATE ELECTRICITY DISTRIBUTION CO. LTD.</b></p> <p><b>P. O. NO. :-</b></p>		
<p><b>NAME OF MANUFACTURE</b></p>		
<p>DATE</p>	<p>SCALE</p>	<p>DATE</p>
<p>APPD</p>	<p>SCALE : N.T.S.</p>	<p>REVISED</p>
<p>GROUP CONTROL OF TAP CHANGE GEAR FOR ---KVA ---KV POWER TRANSFORMER</p>	<p>DRAWING NO./19</p>	<p>DT.</p>

**Technical Specification of 5 MVA and 10 MVA Power Transformer**

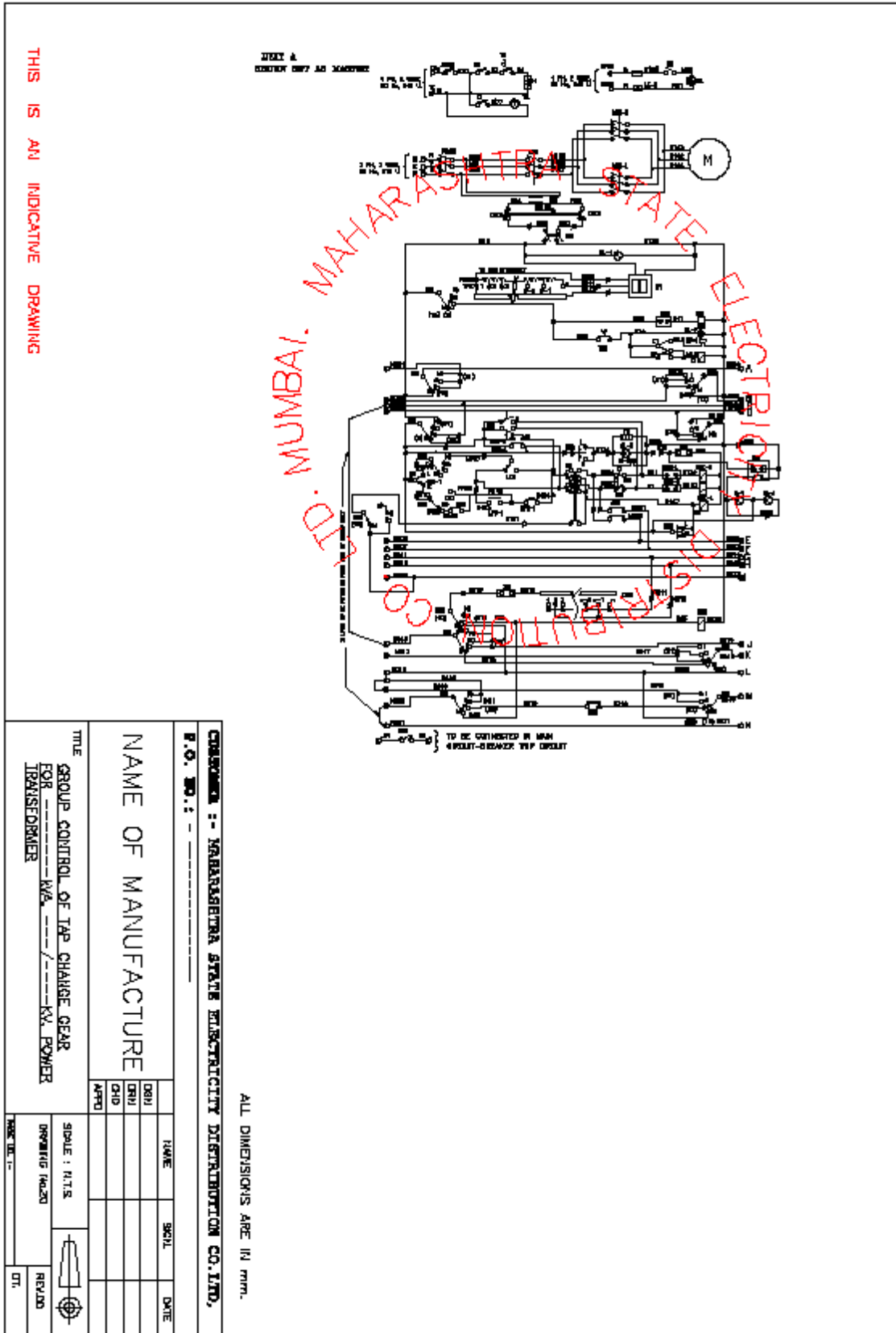

THIS IS AN INDICATIVE DRAWING

**CONTRACT :- MAHARASHTRA STATE ELECTRICITY DISTRIBUTION CO. LTD.**

**P. O. NO. :-** \_\_\_\_\_

**NAME OF MANUFACTURE**

DRN	DATE	SCALE : N.T.S.	
CRN	DATE	DRAWING FILE NO	
APD	DATE	REVISED	

TITLE: GROUP CONTROL OF TAP CHANGE GEAR FOR \_\_\_\_\_ MVA, \_\_\_\_\_ KV. POWER TRANSFORMER  
 DRAWN BY: \_\_\_\_\_  
 CHECKED BY: \_\_\_\_\_  
 DATE: \_\_\_\_\_

ALL DIMENSIONS ARE IN mm.

**Technical Specification of 5 MVA and 10 MVA Power Transformer**

THIS IS AN INDICATIVE DRAWING

MUMBAI. MAHARASHTRA STATE ELECTRICITY

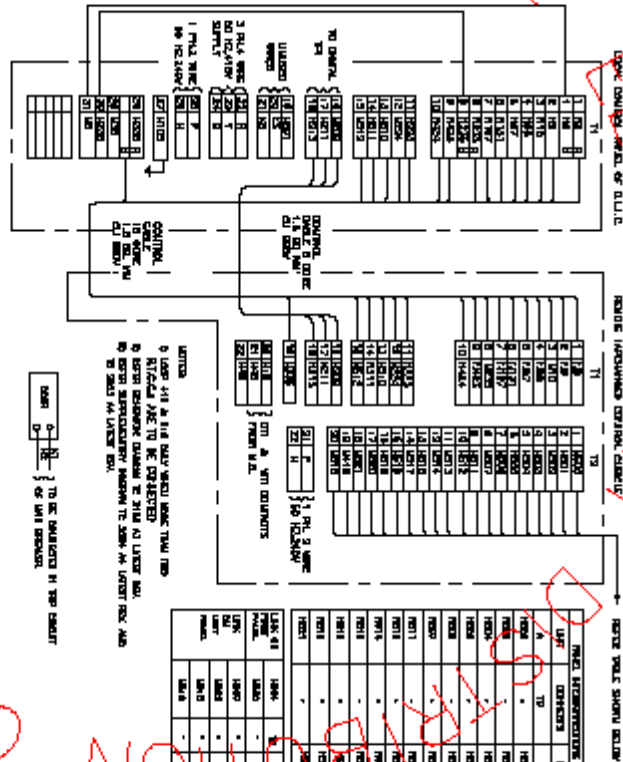

**CONTRACT NO. :-** MAHARASHTRA STATE ELECTRICITY DISTRIBUTION CO. LTD.

**P. O. NO. :-**

**NAME OF MANUFACTURE**

**GROUP CONTROL OF TAP CHANGE GEAR FOR ---KV. POWER TRANSFORMER**

**SCALE : 1:1**

**DATE**

**REVISED**

**DT.**

**Technical Specification of 5 MVA and 10 MVA Power Transformer**

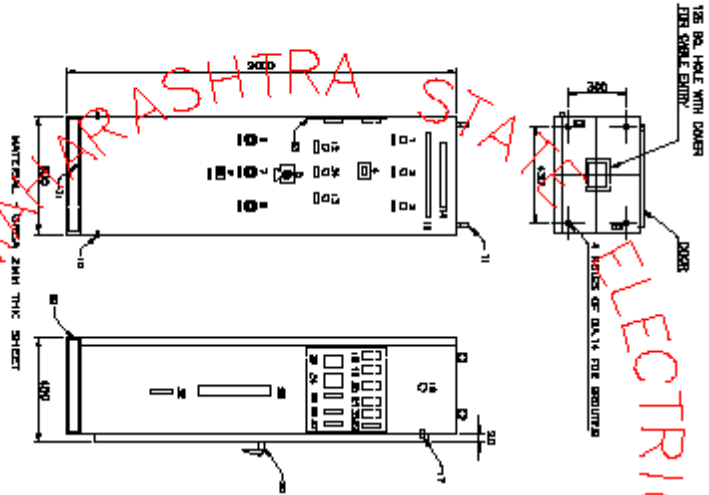

S/N	DESCRIPTION	QTY
1	INDICATING LAMP - PROGRESSIVE RT PROGRESS	SL-3
2	INDICATING LAMP - SUPPLY ON	SL-1
3	INDICATING LAMP - OIL OR STOP	SL-2
4	TEMPERATURE INDICATOR - CENTRAL TUBE	TH1
5	TEMPERATURE INDICATOR - LOWER TUBE	TH2
6	PUSH BUTT (ON) - BLACK	MP-1
7	PUSH BUTT (OFF) - RED	MP-2
8	CONTROL SWITCH - ISOLATION SWITCH	CS-1
9	EARTHING BOLTS (4x2 x 26) 2 NOS.	CS-2
10	LEADING LINES (2 NOS.)	CS-3
11	INDICATING LAMP FOR OIL TEMP. HIGH	SL-4
12	INDICATING LAMP FOR PROGRESSIVE RT	SL-5
13	INDICATING LAMP FOR SUPPLY ON	SL-6
14	INDICATING LAMP FOR OIL OR STOP	SL-7
15	INDICATING LAMP FOR TEMPERATURE HIGH	SL-8
16	ALARM INDICATOR RELAY	AR
17	DOOR SWITCH	DS
18	ALARM INDICATOR RELAY	AR
19	DOOR SWITCH	DS
20	TEMPERATURE INDICATOR	TH
21	TEMPERATURE INDICATOR	TH
22	TEMPERATURE INDICATOR	TH
23	TEMPERATURE INDICATOR	TH
24	TEMPERATURE INDICATOR	TH
25	TEMPERATURE INDICATOR	TH
26	TEMPERATURE INDICATOR	TH
27	TEMPERATURE INDICATOR	TH
28	TEMPERATURE INDICATOR	TH
29	TEMPERATURE INDICATOR	TH
30	TEMPERATURE INDICATOR	TH
31	TEMPERATURE INDICATOR	TH
32	TEMPERATURE INDICATOR	TH
33	TEMPERATURE INDICATOR	TH
34	TEMPERATURE INDICATOR	TH
35	TEMPERATURE INDICATOR	TH

MAHARASHTRA STATE ELECTRICITY DISTRIBUTION CO. LTD. MUMBAI.

THIS IS AN INDICATIVE DRAWING

**CONSUMER :- MAHARASHTRA STATE ELECTRICITY DISTRIBUTION CO. LTD.**

**P. O. NO. :-**

**NAME OF MANUFACTURE**

**TITLE**  
GENERAL ARRANGEMENT OF TAP CHANGER CONTROL PANEL FOR ---KV / ---KV POWER TRANSFORMER

DATE	SCALE : N.T.S.	DATE
DATE	DRAWING NO.	DATE
DATE	REVISED	DATE
DATE	BY	DATE

ALL DIMENSIONS ARE IN MM.

**Technical Specification of 5 MVA and 10 MVA Power Transformer**

**THIS IS AN INDICATIVE DRAWING**

33	GRABET		
32	INSULATION		
31	TRANSFORMER OIL		
30	COPPER		
29	CORE		
28	AN RELEASE PLUG		
27	OIL LEVEL GAUGE INDICATING 3 POS. OF OIL MARKED		
26	CONSERVATOR DRAIN VALVE		
25	L.V. OUTDOOR BUSHING 12 KV 630A		
24	H.V. OUTDOOR BUSHING 33 KV 630A		
23	POCKET FOR DRY		
22	DRAL TYPE OIL MINH. A/T CONTACT		
21	WASHING BOX		
20	THERMOMETRIC FOOTLET		
19	RESPECTION HOLE WITH COVER		
18	PRESURE RELIEF VALVE		
17	SHUT OFF VALVE BTWL. COHV. & TOP COVER		
16	DOUBLE FLOAT BUZHOLD RELAY WITH A/T CONTACT		
15	RAIDITOR SWIK WITH TOP & BOTTOM SHUT OFF VALVE		
14	CR. LOAD TAP CHANGING GEAR WITH OIL SINGCE RELAY		
13	EXPLOSION YEAT WITH EQUALIZER PIPE		
12	DEHYDRATING SUDAGER BREAKER		
11	OIL CONSERVATOR WITH OIL FILLING HOLE & LIFTING LUGS		
10	COVER		
9	JACKING LUG		
8	HALLING EYE		
7	LIFTING LUG		
6	WAVE RITING & MAGRYAL PLATE		
5	OIL SAMPUNG VALVE WITH FLANGE (TOP & BOTTOM)		
4	OIL FILTER VALVE WITH FLANGE (TOP & BOTTOM)		
3	OIL DRAIN VALVE WITH FLANGE		
2	UNDER BASE CHAIRIED WITH B-DIR. FLANGED ROLLERS		
1	EARTHING TERMINALS WITH DRIMPING LUG		
	LIST OF FITTINGS		

**ELECTRICITY DISTRIBUTION CO.**

**ORDER NO. :-** MAHARASHTRA STATE ELECTRICITY DISTRIBUTION CO. LTD,  
P. O. NO. :-

**NAME OF MANUFACTURE**

**SCALE : 1:12.5**

**BILL OF MATERIAL FOR 5 MVA / 10 MVA POWER TRANSFORMER**

DATE	DATE	DATE	DATE
DATE	DATE	DATE	DATE
DATE	DATE	DATE	DATE
DATE	DATE	DATE	DATE

REVISION

**Technical Specification of 5 MVA and 10 MVA Power Transformer**

THIS IS AN INDICATIVE DRAWING

N <sup>o</sup> .	DESCRIPTION	QTY

**CONSUMER :-** MAHARASHTRA STATE ELECTRICITY DISTRIBUTION CO. LTD.

**P.O. No. :-** \_\_\_\_\_

**NAME OF MANUFACTURE**

**TITLE**

PACKING LIST  
FOR \_\_\_\_\_ KVA \_\_\_\_\_ KV POWER  
TRANSFORMER

NO.	NAME	SCALE	DATE
DBH			
DNH			
CHD			
APD			

SCALE : N.T.S.

DRAWING No. 24

REVISED

DATE

MUMBAI. MAHARASHTRA STATE ELECTRICITY DISTRIBUTION CO.

ALL DIMENSIONS ARE IN mm.