



Maharashtra State Electricity Distribution Company Limited

SPECIFICATION NO. MMC: MSC-II/Multi Meter box/SMC/2018/10

TECHNICAL SPECIFICATION

FOR

FOR MULTI-METER BOX SUITABLE FOR HOUSING 4/8/12/18 NOS.OF SINGLE PHASE METERS OR THREE PHASE METERS MADE OUT OF GLASS REINFORCED POLYESTER SHEET MOULDING COMPOUND (S₃ GRADE)/ POLYCARBONATE/ CRCA MS DEEP DRAWN OR FABRICATION FOR

DISTRIBUTION SYSTEM

IN

MSEDCL

INDEX

Clause No.	Contents
	MULTI-METER BOX SUITABEL FOR HOUSING 4/8/12/18 NOS. SINGLE PHASE METERS OR THREE PHASE METERS MADE OUT OF GLASS REINFORCED POLYESTER SHEET MOULDING COMPOUND (S3 GRADE)/POLYCARBONATE MATERIAL/ CRCA MS DEEP DRAWN OR FABRICATION
1.	SCOPE
2.	SERVICE CONDITIONS
3.	SYSTEM DETAILS
4.	APPLICABLE STANDARDS
5.	DESIGN & CONSTRUCTION OF BOXES
6.	TESTS
7.	TESTING AND MANUFACTURING FACILITIES
8.	DRAWING /SAMPLE
9.	MARKING/EMBOSSING
10.	PACKING
11.	GUARANTEED TECHNICAL PARTICULARS
12.	DRAWING

MAHARASHTRA STATE ELECTRICITY DISTRIBUTION COMPANY

Technical Specifications for

FOR MULTI-METER BOX SUITABLE FOR HOUSING 4/8/12/18 NOS. OF SINGLE PHASE METERS OR THREE PHASE METERS MADE OUT OF SHEET MOULDING COMPOUND(S3 GRADE) (SMC)/POLYCARBONATE/CRCA MS DEEP DRAWN OR FABRICATION.

SPECIFICATION NO. MMC: MSC-II/Multi Meter box/SMC/2018/10

1.00 SCOPE:

Specification covers the design, manufacture, testing at works and supply of Multi-meter box made out of **glass reinforced polyester sheet moulding compound (S₃ grade)/ Polycarbonate/ CRCA MS Deep Drawn or Fabrication** for housing 4/8/12/18 nos. of Single Phase meters or Three Phase meters. The system shall be A.C. Single phase 250 V or three phase, four wires, 433 V, 50 Hz with effectively grounded neutral. Multi-meter box made out of **glass reinforced polyester sheet moulding compound (S₃ grade)/ Polycarbonate** shall preferably be used in coastal areas to avoid corrosion problems.

2.00 SERVICE CONDITION

The equipment to be supplied against this specification shall be suitable for satisfactory continuous operation under the following tropical conditions.

2.1	Maximum ambient temperature (Degree C)	50
2.2	Maximum temperature in shade (Degree C)	45
2.3	Minimum Temperature (Degree C)	3.5
2.4	Relative Humidity (percent)	10 to 95
2.5	Maximum Annual rain fall (mm)	1450
2.6	Maximum wind pressure (kg/sq.m)	150
2.7	Maximum altitude above mean sea level (Meter)	1000
2.8	Isoceranic level (days per year)	50
2.9	Siesmic level (Horizontal Acceleration)	0.3 g

Moderately hot and humid tropical climate conducive to rust and fungus growth..

3.00 SYSTEM DETAILS

Multi-meter boxes are meant for housing multiple Single Phase meters or Three Phase meters with relevant system parameters as under:-

S.N.	Particulars	Details
1.	Voltage	250 V, 1Ph 433 V, 3 Ph, ($\sqrt{3} \times 250$ V)
2.	Frequency	50 HZ
3.	Phases	1 phase, solidly grounded neutral 3 phase, solidly grounded neutral

4.00 APPLICABLE STANDARDS

- a. Glass reinforced polyester sheet moulding compound (S3 grade)- IS:13410-1992
- b. Polycarbonate- IS: 14434-1998
- c. For enclosure- IS 14772:2000

5.00 DESIGN & CONSTRUCTION OF BOXES:

5.01 The Multi-Meter Box shall be made from Thermosetting Plastic i.e. Glass reinforced polyester sheet moulding compound (S3 grade) conforming IS:13410-1992/ Polycarbonate conforming IS: 14434-1998/ CRCA MS Deep Drawn or Fabrication and as per requirement of this specification. The base and cover of Multi-meter box shall be individually in one piece except for fixing of accessories like hinges, clamp, handles etc, CRCA MS Fabrication and all metal part shall be Zinc –Passivated.

5.02 In case of Deep drawn type Multi-meter boxes, the rounding of corners and slope on Top shall be as shown in the drawing. No joints in the body of the Box are permitted in Deep Drawn Process.

In case of fabricated box sharp corners & one side slope will be acceptable. The fabrication boxes, involving welding, shall not have more than two joints

5.03

- a. For Multi-Meter Box made from Glass reinforced polyester sheet moulding compound (S3 grade)- The wall thickness of Multi-Meter box shall not be less than 3 mm on load bearing side and 2 mm for all other sides including door.
- b. For Multi-Meter Box made from Polycarbonate material -The wall thickness of Multi-Meter box shall not be less than 3 mm on load bearing side and 2 mm for all other sides including door.
- c. For Multi-Meter Box made from CRCA MS Deep Drawn or Fabrication - The thickness of Multi-Meter box shall not be less than 2 mm all sides including door.

5.04 Multi-Meter box shall be so constructed so as to have roof tapering down for easy flow of rain water.

5.05 It shall be anti corrosive, dust proof, vermin and water proof, Ultra violet ageing test stabilized and flame-retardant property

5.06 The internal dimensions of Multi-Meter box shall be as under

Sr. No.	Description	Internal Dimensions (Min) Ht x Width x Depth (mm)
1	Multi-Meter Box for Housing 4 Nos. Single Phase Meter	530 x 450 x 150 mm
2	Multi-Meter Box for Housing 8 Nos. Single Phase Meter	750 x 690 x 150 mm
3	Multi-Meter Box for Housing 12 Nos. Single Phase Meter	1000 x 690 x 150 mm

4	Multi-Meter Box for Housing 18 Nos. Single Phase Meter	1100 x 1100 x 150 mm
---	--	----------------------

- 5.07** The Multi-Meter Box should have viewing window as shown in the drawing.
- 5.08** The viewing window shall be provided with toughened glass of 5 mm thickness and Minimum 5 mm over lapping of glass with viewing window. The glass shall be fixed from inside of the cover of Multi-meter box with stainless steel frame (glass holder)with suitable rubber gasket from inside the cover, so that it can withstand weather effect.
- 5.09** The multi meter box should not change in color, shape, size, dimension when subjected to 200 hours on Ultra violet ageing test for SMC and polycarbonate material. Also it shall be capable of withstanding temperature of boiling water for five minutes continuously without distortion or softening.
- 5.10** The Multi Meter box shall be fixed by stainless steel concealed hinges on one side with hardware from insides in such a manner that it can't be manipulated from outside. It should have locking arrangement by way of sealing and can be opened without breaking.
- 5.11** Locking arrangement shall be such that MS Chrome Plated Triangular Lock with Key for locking of Multi-Meter Box to be provided.
- 5.12** The door in closed position should be overlapped on base such that direct entry of screwdriver, tool or film is not possible.
- 5.13** Multi-Meter Box shall confirm to IP-51.
- 5.14** The dimensions of bus bar shall be as under

Sr. No.	Description	Dimensions (Min) Ht x Width x Depth (mm) of Phase busbar	Dimensions (Min) Ht x Width x Depth (mm) of neutral busbar
1	Multi-Meter Box for Housing 4 Nos. Single Phase Meter	160 x 20 x 5 mm	160 x 20 x 5 mm
2	Multi-Meter Box for Housing 8 Nos. Single Phase Meter	300 x 25 x 6 mm 3 no.	300 x 40 x 6 mm
3	Multi-Meter Box for Housing 12 Nos. Single Phase Meter	300 x 25 x 6 mm 3no.	300 x 40 x 6 mm
4	Multi-Meter Box for Housing 18 Nos. Single Phase Meter	390 x 25 x 8 mm 3no.	390 x 50 x 6 mm

- 5.15** Phase busbars shall be placed in bottom right of multi meter box and neutral busbar shall be placed in bottom left of multi meter box as indicated in drawing.
- 5.16** The mounting arrangement of the meter shall be on 10 mm thick Particle Board as per drawing
- 5.17** For fixing on wall mounting, flat is to be provided along with nut bolts with the Multi-Meter box as shown in the drawing.

For pole mounting, necessary M.S. Clamp arrangement to be made for mounting the Multi-Meter Box on pole

5.18 Incoming and Outgoing cable entry holes shall be as under

Sr. No.	Description	Incoming Cable entry hole	Outgoing Cable Entry hole
1	Multi-Meter Box for Housing 4 Nos. Single Phase Meter	1 No. Dia. 32 mm Incoming Cable entry hole with Gland should be provided at base as shown in the drawing.	4 Nos. Dia. 16 mm Outgoing cable entry holes with Gland as shown in the drawing.
2	Multi-Meter Box for Housing 8 Nos. Single Phase Meter	2 Nos. Dia. 32 mm Incoming Cable entry hole with Gland should be provided at base as shown in the drawing.	8 Nos. Dia. 16 mm Outgoing cable entry holes with Gland as shown in the drawing.
3	Multi-Meter Box for Housing 12 Nos. Single Phase Meter		12 Nos. Dia. 16 mm Outgoing cable entry holes with Gland as shown in the drawing.
4	Multi-Meter Box for Housing 18 Nos. Single Phase Meter		18 Nos. Dia. 16 mm Outgoing cable entry holes with Gland as shown in the drawing.

5.19 The surface appearance of part must be smooth, non porous and homogeneous, free of ripples, defects and marks. No fillers or fibers should be visible at any place

6.00 TESTS

6.01 TYPE TESTS

The multi meter box shall have been successfully type tested as per IS: 14772 / 2000 from NABL Accredited independent testing laboratories such as CPRI/ERDA. The type test report shall clearly indicate the constructional features of the type tested multi meter box. The tenderer shall also furnish certificate from laboratories where type test carried out. The requisite test facility available in house for that particular test shall be approved by NABL. The type tests conducted in manufacturer's own laboratory and certified by testing institute shall not be acceptable. The tenderer shall also furnish the particulars giving specific required details of multi meter box in schedule 'A' attached (As per Guaranteed Technical Particulars uploaded on e - Tendering site). The offers without the details in schedule 'A' and Type Test reports stands rejected.

A. Type Test, Acceptance Tests and Routine tests for Sheet Moulding Compound

(SMC) Multi Meter Box

The Enclosure Sheet Moulding Compound (SMC) conforming IS: 13410-1992 should have following properties:

I. Type tests

Sr.no	Test Details	Requirement for S3 electrical Grade	Reference standard
1.	Glass Content , % by mass, minimum	20	Annexure –A of IS : 13411: 1992
2.	Flexural Strength, MPa	170	Annex. F of IS 13411:1992.
3.	Modulus of Elasticity, 103 MPa	12 to 15	IS 8543 (Part 4/Sec 1) : 1984
4.	Tracking Resistance CTI, Min	1000	IS2824:1975
5.	Dielectric Strength at 90°C In Oil KV/Min	11	IS 6262:1971
6.	Dissipation factor (4 days at 80% RH & 1 KHz)	0.01	IS4486:1967
7.	Heat Distortion Temperature, C, Min	150	Annex. H of 13411:1992
8.	Oxygen Index, % Min	24	IS 13360 (Part6/Sec6):1992
9.	Flammability (Vo)	-	UL 94 or IS : 11731 (Pt.II)
10.	Glow wire test	-	IEC – 695 –2-1 or IS :11000(Pt 2/sec.1)
11.	Ball pressure test	-	IEC : 335
12.	Mechanical Strength	-	IS : 14772
13.	Spirit burner test (Self Extinguishing)	-	IS : 4249
14.	Melting point (to test up to 400°C) should not melt		IS :13360

II. Acceptance tests

Sr.no	Test Details	Requirement for S3 electrical Grade	Reference standard
1.	Flow, mm, Min	170	Annexure – C of IS : 13411: 1992
2.	Mould shrinkage , linear percent, Max	0.25	Annexure – B of IS : 13411: 1992
3.	Water Absorption, % Max.	0.01	Annex. D of of IS : 13411: 1992
4.	Izod Impact Strength (Notched), KJ/m ² , Min	55	Annex.E of IS : 13411: 1992
5.	Tensile Strength , MPa, Min	70	IS:8543 (part 4/1984)
6.	Power Arc Resistance, sec, Min	180	Annex. G of IS 13411:1992

III. Routine tests

Sr.no	Test Details	Requirement for S3 electrical Grade	Reference standard
-------	--------------	-------------------------------------	--------------------

1.	Density of Moulding , g/ml	1.8 to 2.1	IS:8543 (part 1/Sec2:1970)
2.	Surface Resistivity (24H in Water), Ohm, Min	1×10^{13}	IS3396:1979
3.	Volume Resistivity , Ohm-cm, Min	1×10^{14}	IS3396:1979
4.	Marking, Dimensions and construction	-	IS : 14772

B. Type Test & Acceptance Tests for Polycarbonate Material Meter Box

I. The tests for properties of polycarbonate material confirming to IS:14434:1998 are mentioned below:

- a) Specific gravity
- b) Flexural Modulus
- c) Impact strength
- d) Temperature Deflection under load
- e) Volume resistivity
- f) Dielectric strength
- g) Dielectric constant
- h) Dissipation factor
- i) Flammability test

Following tests shall be conducted on meter cover confirming to IS:14772/2000 and IS:14434/1998 as mentioned below:

Sr. No.	Test	Reference Standard
1.	Material Identification of Cover (poly carbonate)	IS:14434/1998
2.	Marking, Dimension & Construction	IS:14772 / 2000
3.	Protection against electric shock	IS:14772 / 2000
4.	Provision for earthing	IS:14772 / 2000
5.	Resistance to ageing, humid conditions, Ingress of solid objects and to harmful ingress of water	IS:14772 / 2000
6.	Mechanical strength	IS:14772 / 2000
7.	Resistance to heat/ Ball Pressure Test	IS:14772 / 2000
8.	Resistance of insulating material to abnormal heat and fire	IS:14772 / 2000
9.	Resistance to Tracking	IS:14772 / 2000
10.	Flammability (V2)	UL 94 or IS: 11731 (Part. II)
11.	Self extinguishing	IS: 4249/1967
12.	Heat deflection temperature	ISO 75
13.	Glow Wire Test	IS: 11000 (Part 2/ Sec-1) or IEC -60695-2-12
14.	Ball Pressure Test	IEC: 335 or IEC-60695-10-2
15.	Water Absorption	IS:5133 (Part-II)-1969
16.	Light Transmission (Transparency) for Cover	ASTM D 1003
17.	UV Ageing Test for 200 Hours	ASTM G53 (9.3)

6.02 ACCEPTANCE AND ROUTINE TESTS

The following Tests shall constitute the Acceptance & Routine Tests. All Acceptance & Routine Tests shall be carried out by supplier in presence of Purchaser's Representative.

Immediately after finalization of the program of Type/Acceptance/Routine testing, the supplier shall give three weeks advance intimation to purchaser, to enable him to depute his representative for witnessing the tests

Sr. No.	Test	Reference Standard
1	Marking	IS 14772:2000
2	Dimensions	IS 14772:2000
3	Protection against Electric Shock	IS 14772:2000
4	Provision for Earthing	IS 14772:2000
5	Construction	IS 14772:2000
6	Resistance to Ageing, to humid condition, to ingress of solid objects and to harmful ingress of water	IS 14772:2000
7	Mechanical Strength	IS 14772:2000
8	Density of Moulding, g/ml	IS:13410-1992
9	Surface Resistivity (24 hrs in water), Ohm	IS:13410-1992
10	Volume Resistivity, Ohm-cm	IS:13410-1992
11	Impact Strength, KJ/m ²	IS:13410-1992
12	Tensile Strength, MPa	IS:13410-1992
13	Power Arc Resistance, sec	IS:13410-1992
14	Heat Distortion Temperature, Deg. C	IS:13410-1992

7.00 TESTING AND MANUFACTURING FACILITIES

7.01 The manufacturer shall have necessary machinery for production of SMC/Polycarbonate/CRCA MS Deep Drawn or Fabrication Multi meter box

7.02 The manufacturer shall have in house testing facilities for carrying out following tests:

Sr. No.	Test Details	Reference standard
1.	Flammability (V2)	UL 94 or IS: 11731 (Pt. II)
2.	Heat deflection temp. at (min. 150 ^o C) 0.45 SUB MPA Load	ISO 75
3.	Glow wire test	IEC-695-2-1 or IS: 11000 (Pt 2/sec.1)
4.	Ball pressure test	IEC: 335
5.	Water absorption	IS: 14772
6.	Mechanical Strength	IS: 14772

7.	Marking Dimensions and construction	IS: 14772
8.	Spirit burner test	IS: 4249

8.00 DRAWING /SAMPLE:

Enclosed drawings are only for general guidelines, however, the detailed dimensional drawing showing clearly the dimensions and material of Multi-Meter Box and its constructional features should invariably furnished with the offer.

9.00 MARKING / EMBOSSING

The following information shall be clearly and indelibly embossed (not printed) on the cover of the Multi-meter box except Sr. No. which may be **indelibly printed with inkjet** printing on the base and cover of the Multi- meter box.

- (i) Purchase order number and date.
- (ii) Year and month of manufacture.
- (iii) Purchaser's name: MSEDCL
- (iv) Guarantee: **1 Year.**
- (v) Sign of danger.
- (vi) Code name of manufacturer

10.00 PACKING

The Multi-meter box shall be suitably packed in corrugated boxes in order to avoid damage during transit or handling

**GURANTEED TECHNICAL PARTICULARS OF MULTI-METER BOXES SUITABLE FOR
HOUSING 4 NOS. OF METERS**

Sr. No.	Particulars	Required	Offered
1	Material	Glass reinforced polyester sheet Moulding compound (SMC)/Polycarbonate/ CRCA MS Deep Drawn or Fabrication	
2	Grade of Material	As per IS:13410-1992/ IS: 14434-1998	
3	<u>Properties of Material of Construction of Multi-Meter Box</u>		
A	Flammability (Ref. Std: UL-94 / IS-11731)	V0	
b	Heat Deflection Temperature (Ref. Std. IS:13411)	150 Deg. C (Minimum)	
C	Exposure to Flame (Ref. Std. IS – 4249)	Self Extinguishing	
D	Melting Point (Ref. Std. IS-13360)	Does not Melt	
4	<u>Constructional features of the Multi-Meter Box:</u>		
4(a)	Clear inside dimensions		
i.	Height	530 mm	
ii.	Width	450 mm	
iii.	Depth	150 mm	
iv.	Thickness	3 mm on load bearing side and 2mm all other sides including door	
4(b)	<u>Window on front door:</u>		
i.	Material of Viewing Window	Toughened Glass	
ii.	No. of Viewing Window	2 Nos.	
iii.	Thickness of Toughened Glass	5 mm	
iv.	Size of opening (Min)	366 x 120 mm (+ 5 mm)	
v.	Fixing method	Fixed from inside with stainless steel frame and gasket	
5	Hinges	Stainless Steel Continuous Strip Hinge	
6	Locking Arrangement	2 Nos. MS Chrome Plated Triangular Lock with Common Key	
7	Pad Locking Arrangement	Hole for pad locking to be provided	
8	Sealing Arrangement	Holes for Wire Seal in SS Door Closing Clamp	
9	Earthing Bolt	2 Nos. Earthing bolt of MS zinc Passivated of size M6 x 25 mm long with two nuts and two washer.	
10	Wire Entry Incoming Cables	1 No. Dia. 32 mm Incoming Cable entry hole with Gland at the base	
11	Wire Entry Outgoing Cables	4 Nos. Dia. 16 mm Outgoing cable entry holes with Gland	
12	Meter Mounting Arrangement	10 mm thick particle board	
13	Ingress Protection (IP)	IP-51	

GUARANTEED TECHNICAL PARTICULARS OF MULTI-METER BOXES SUITABLE FOR HOUSING 8 NOS. OF METERS

Sr. No.	Particulars	Required	Offered
1	Material	Glass reinforced polyester sheet Moulding compound (SMC) /Polycarbonate/CRCA MS Deep Drawn or Fabrication	
2	Grade of Material	As per IS:13410-1992 /IS: 14434-1998	
3	<u>Properties of Material of Construction of Multi-Meter Box</u>		
a	Flammability (Ref. Std: UL-94 / IS-11731)	V0	
b	Heat Deflection Temperature (Ref. Std. IS:13411)	150 Deg. C (Minimum)	
C	Exposure to Flame (Ref. Std. IS – 4249)	Self Extinguishing	
D	Melting Point (Ref. Std. IS-13360)	Does not Melt	
4	<u>Constructional features of the Multi-Meter Box:</u>		
4(a)	Clear inside dimensions		
i.	Height	750 mm	
ii.	Width	690 mm	
iii.	Depth	150 mm	
iv.	Thickness	3 mm on load bearing side and 2mm all other sides including door	
4(b)	<u>Window on front door:</u>		
i.	Material of Viewing Window	Toughened Glass	
ii.	No. of Viewing Window	2 Nos.	
iii.	Thickness of Toughened Glass	5 mm	
iv.	Size of opening (Min)	570 x 120 mm (+ 5 mm)	
v.	Fixing method	Fixed from inside with stainless steel frame and gasket	
5	Hinges	Stainless Steel Continuous Strip Hinge	
6	Handle	1 Nos. Stainless Steel Handle	
7	Locking Arrangement	2 Nos. MS Chrome Plated Triangular Lock with Common Key	
8	Pad Locking Arrangement	Hole for padlocking to be provided	
9	Sealing Arrangement	Holes for Wire Seal in SS Door Closing Clamp	
10	Earthing Bolt	2 Nos. Earthing bolt of MS zinc Passivated of size M6 x 25 mm long with two nuts and two washer.	
11	Wire Entry Incoming Cables	2 Nos. Dia. 32 mm Incoming Cable entry hole with Gland at the base	
12	Wire Entry Outgoing Cables	8 Nos. Dia. 16 mm Outgoing cable entry holes with Gland	
13	Louvers	1 Nos. FRP Louver on each side wall	

Sr. No.	Particulars	Required	Offered
14	Meter Mounting Arrangement	10 mm thick particle board	
15	PVC Wire Alley for wiring	2 Nos.	
16	Ingress Protection (IP)	IP-51	
17	Bus Bar for Phase (R,Y,B)	Aluminum Bus Bar of size 25 x 8 mm with Insulation tape having M6 x 20 mm bolts	
18	Bus Bar for Neutral	Aluminum Bus Bar of size 40 x 6 mm with Insulation tape having M6 x 20 mm bolts	
19	Bus Bar	SMC Step for Bus Bar mounting	
20	Colour of Meter Box	Off White	

GURANTEED TECHNICAL PARTICULARS OF MULTI-METER BOXES SUITABLE FOR HOUSING 12 NOS. OF METERS

Sr. No.	Particulars	Required	Offered
1	Material	Glass reinforced polyester sheet Moulding compound (SMC) /Polycarbonate/CRCA MS Deep Drawn or Fabrication	
2	Grade of Material	As per IS:13410-1992/ IS: 14434-1998	
3	<u>Properties of Material of Construction of Multi-Meter Box</u>		
a	Flammability (Ref. Std: UL-94 / IS-11731)	V0	
b	Heat Deflection Temperature (Ref. Std. IS:13411)	150 Deg. C (Minimum)	
C	Exposure to Flame (Ref. Std. IS – 4249)	Self Extinguishing	
D	Melting Point (Ref. Std. IS-13360)	Does not Melt	
4	<u>Constructional features of the Multi-Meter Box:</u>		
4(a)	Clear inside dimensions		
i.	Height	1000 mm	
ii.	Width	690 mm	
iii.	Depth	150 mm	
iv.	Thickness	3 mm on load bearing side and 2mm all other sides including door	
4(b)	<u>Window on front door:</u>		
i.	Material of Viewing Window	Toughened Glass	
ii.	No. of Viewing Window	3 Nos.	
iii.	Thickness of Toughened Glass	5 mm	
iv.	Size of opening (Min)	570 x 120 mm (± 5 mm)	
v.	Fixing method	Fixed from inside with stainless steel frame and gasket	
5	Hinges	Stainless Steel Continuous Strip Hinge	
6	Handle	2 Nos. Stainless Steel Handle	
7	Locking Arrangement	2 Nos. MS Chrome Plated Triangular Lock with Common Key	
8	Pad Locking Arrangement	1 Nos. Padlocking arrangement of 2 mm thick SS-304	
9	Sealing Arrangement	Holes for Wire Seal in SS Door Closing Clamp	
10	Earthing Bolt	2 Nos. Earthing bolt of MS zinc Passivated of size M6 x 25 mm long with two nuts and two washer.	
11	Wire Entry Incoming Cables	Dia. 32 mm Incoming Cable entry hole with Gland at the base	
12	Wire Entry Outgoing Cables	12 Nos. Dia. 16 mm Outgoing cable entry holes with Gland	
13	Louvers	1 Nos. FRP Louver on each side wall	

Sr. No.	Particulars	Required	Offered
14	Meter Mounting Arrangement	10 mm thick particle board	
15	PVC Wire Alley for wiring	3 Nos.	
16	Ingress Protection (IP)	IP-51	
17	Bus Bar for Phase (R,Y,B)	Aluminum Bus Bar of size 25 x 8 mm with Insulation tape having M6 x 20 mm bolts	
18	Bus Bar for Neutral	Aluminum Bus Bar of size 40 x 6 mm with Insulation tape having M6 x 20 mm bolts	
19	Bus Bar	SMC Step for Bus Bar mounting	
20	Colour of Meter Box	Off White	

**GURANTEED TECHNICAL PARTICULARS OF MULTI-METER BOXES SUITABLE FOR
HOUSING 18 NOS. OF METERS**

Sr. No.	Particulars	Required	Offered
1	Material	Glass reinforced polyester sheet Moulding compound (SMC) /Polycarbonate/CRCA MS Deep Drawn or Fabrication	
2	Grade of Material	As per IS:13410-1992 /IS: 14434-1998	
3	<u>Properties of Material of Construction of Multi-Meter Box</u>		
a	Flammability (Ref. Std: UL-94 / IS-11731	V0	
b	Heat Deflection Temperature (Ref. Std. IS:13411)	150 Deg. C (Minimum)	
C	Exposure to Flame (Ref. Std. IS – 4249	Self Extinguishing	
D	Melting Point (Ref. Std. IS-13360	Does not Melt	
4	<u>Constructional features of the Multi-Meter Box:</u>		
4(a)	Clear inside dimensions		
i.	Height	1100 mm	
ii.	Width	1100 mm	
iii.	Depth	150 mm	
iv.	Thickness	3 mm load bearing side and 2mm all other sides including door	
4(b)	<u>Window on front door:</u>		
i.	Material of Viewing Window	Toughened Glass	
ii.	No. of Viewing Window	6 Nos.	
iii.	Thickness of Toughened Glass	5 mm	
iv.	Size of opening (Min)	425 x 120 mm (+ 5 mm)	
v.	Fixing method	Fixed from inside with stainless steel frame and gasket	
5	Hinges	Stainless Steel Continuous Strip Hinge	
6	Handle	2 Nos. Stainless Steel Handle	
7	Locking Arrangement	2 Nos. MS Chrome Plated Triangular Lock with Common Key	
8	Pad Locking Arrangement	1 Nos. Padlocking arrangement of 2 mm thick SS-304	
9	Earthing Bolt	2 Nos. Earthing bolt of MS zinc Passivated of size M6 x 25 mm long with two nuts and two washer.	
10	Wire Entry Incoming Cables	2 Nos. Dia. 32 mm Incoming Cable entry hole with Gland at the base	
11	Wire Entry Outgoing Cables	18 Nos. Dia. 16 mm Outgoing cable entry holes with Gland	
12	Louvers	2 Nos. FRP Louver on each side wall	

Sr. No.	Particulars	Required	Offered
13	Meter Mounting Arrangement	10 mm thick particle board	
14	PVC Wire Alley for wiring	3 Nos.	
15	Ingress Protection (IP)	IP-51	
16	Bus Bar for Phase (R,Y,B)	Aluminum Bus Bar of size 25 x 8 mm with Insulation tape having M6 x 20 mm bolts	
17	Bus Bar for Neutral	Aluminum Bus Bar of size 40 x 6 mm with Insulation tape having M6 x 20 mm bolts	
18	Bus Bar	SMC Step for Bus Bar mounting	
19	Colour of Meter Box	Off White	

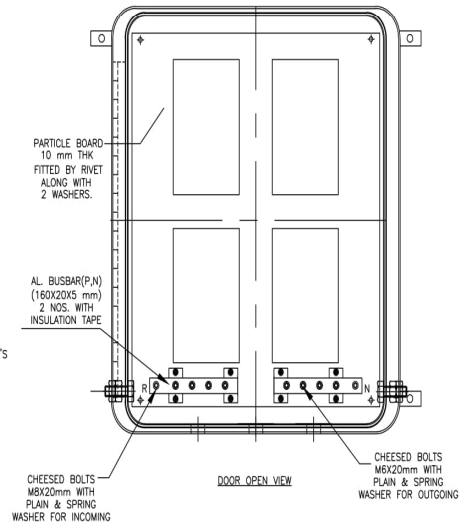
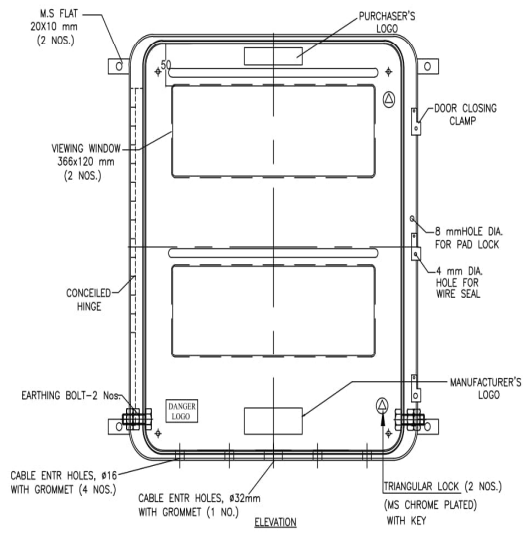
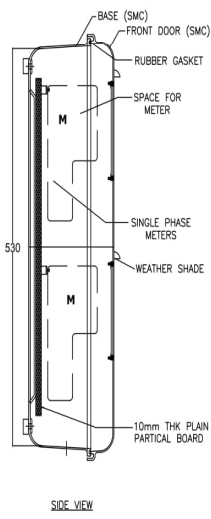
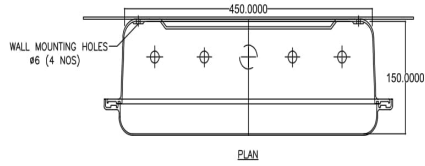

ALL DIMENSIONS IN MM

M.S.E.D.C.L

DISTRIBUTION SECTION

	DESIGNATION	SIGN	DATE
DRAWN BY			
CHECKED BY			
RECOMMENDED BY			
APPROVED BY			

TITLE : MULTI METER BOX FOR 4 NOS.SINGLE PHASE METER

SCALE- N.T.S

THIRD ANGLE PROJECTION



DRG NO.MSEDCL/DIST/MSC-08
REV 0

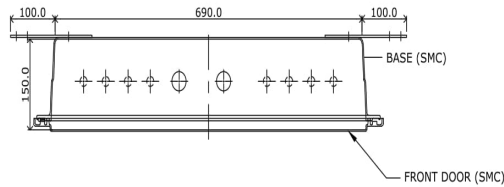

PLAN

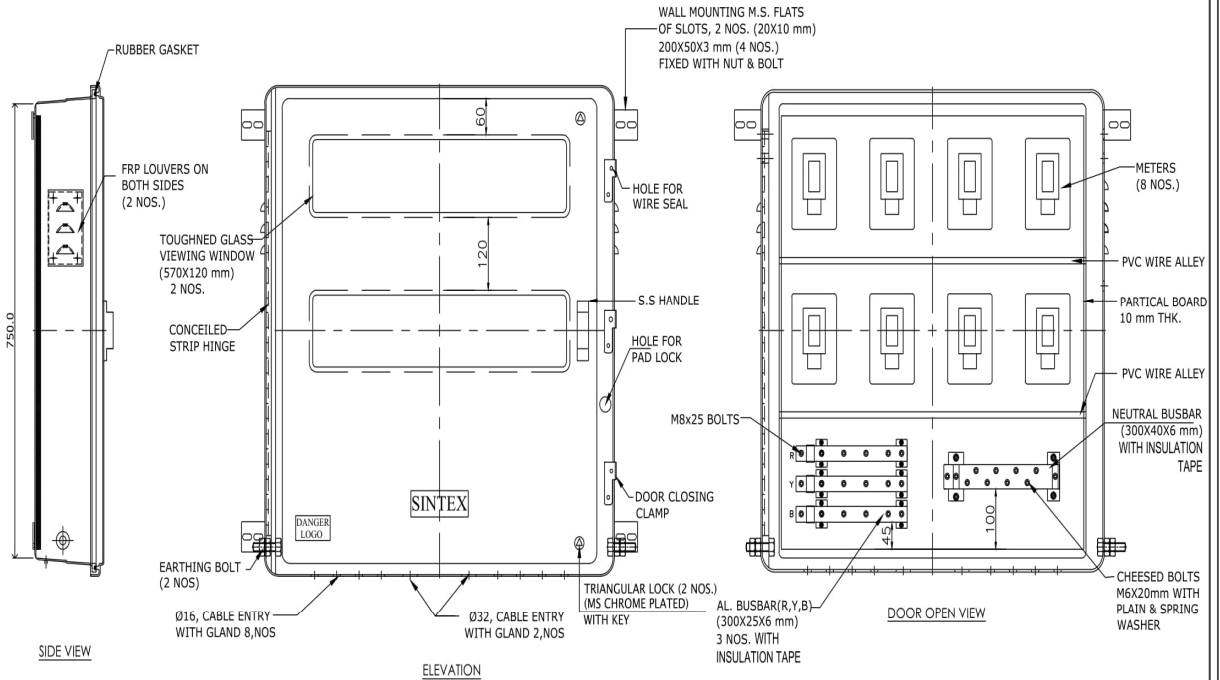

SIDE VIEW

ELEVATION

DOOR OPEN VIEW

ALL DIMENSIONS IN MM				M.S.E.D.C.L	
				DISTRIBUTION SECTION	
DESIGNATION	SIGN	DATE	TITLE : MULTI METER BOX FOR 8 NOS.SINGLE PHASE METER		
DRAWN BY			SCALE- N.T.S		
CHECKED BY			DRG NO.MSEDCL/DIST/MSC-08		
RECOMMENDED BY			REV 0		
APPROVED BY					
THIRD ANGLE PROJECTION					

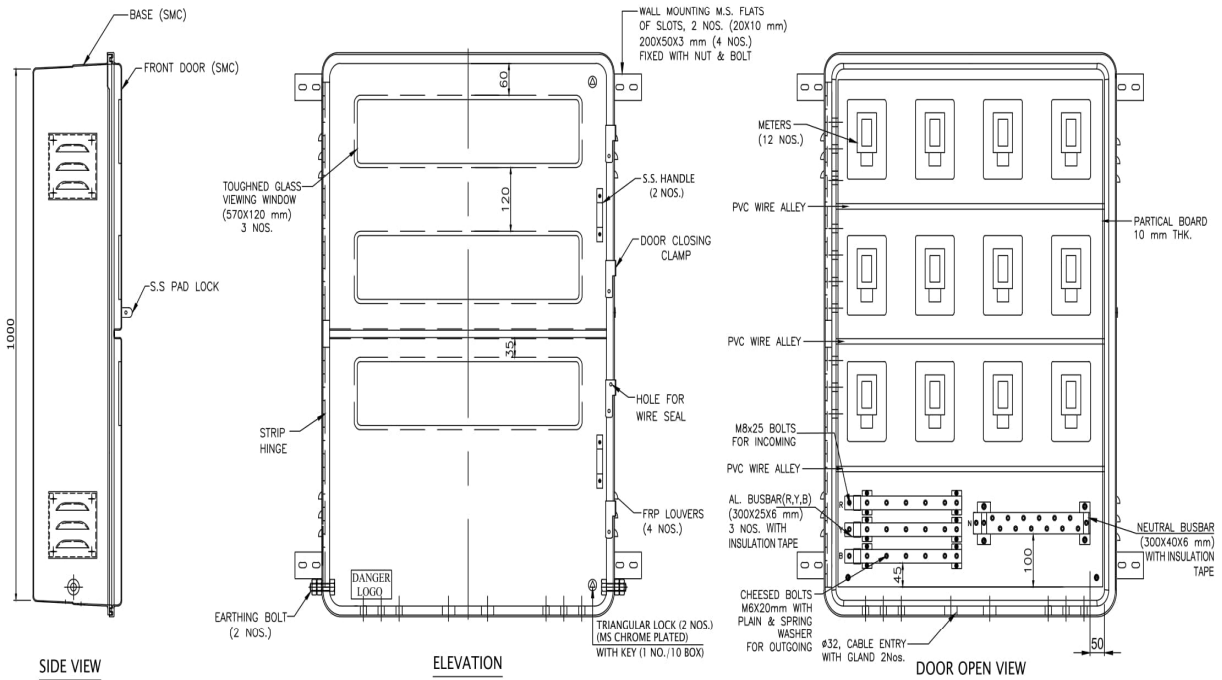
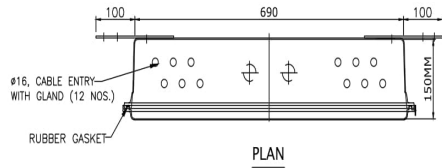

SIDE VIEW

ELEVATION

DOOR OPEN VIEW

THIS IS AN INDICATIVE DRAWING

ALL DIMENSIONS IN MM				M.S.E.D.C.L
				DISTRIBUTION SECTION
DRAWN BY	DESIGNATION	SIGN	DATE	TITLE : MULTI METER BOX FOR 12 NOS.SINGLE PHASE METER
CHECKED BY				
RECOMMENDED BY				
APPROVED BY				SCALE - N.T.S
THIRD ANGLE PROJECTION				DRG NO.MSEDCL/DIST/MSC-08 REV 0

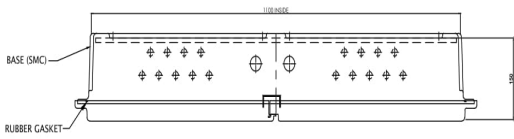

PLAN

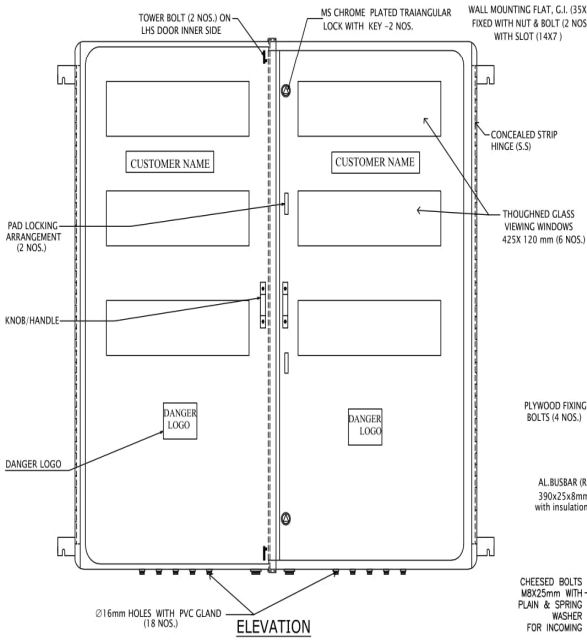

ELEVATION

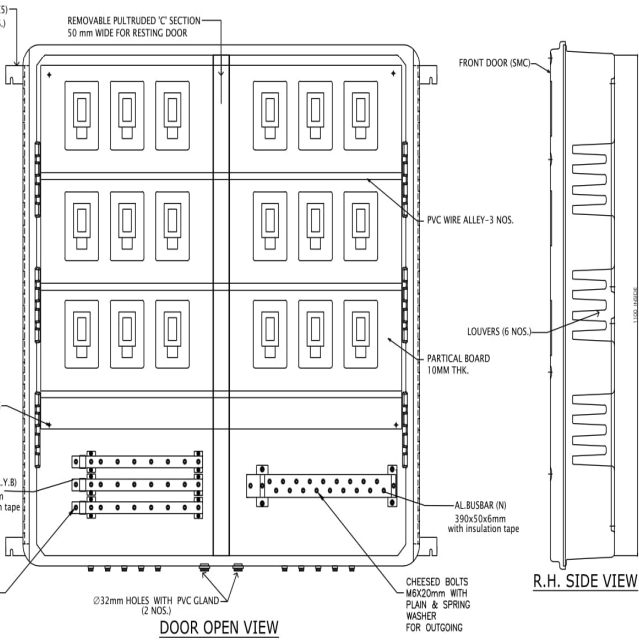

DOOR OPEN VIEW

R.H. SIDE VIEW

THIS IS AN INDICATIVE DRAWING

ALL DIMENSIONS IN MM				M.S.E.D.C.L
				DISTRIBUTION SECTION
	DESIGNATION	SIGN	DATE	TITLE : MULTI METER BOX FOR 18 NOS.SINGLE PHASE METER
DRAWN BY				
CHECKED BY				
RECOMMENDED BY				
APPROVED BY				SCALE - N.T.S
THIRD ANGLE PROJECTION				DRG NO.MSEDCL/DIST/MSC-09