



Maharashtra State Electricity Distribution Co. Ltd.

SPEC. NO. STORES:MSC-II/33kV Isolator/2011

TECHINCAL SPECIFICATION

FOR

33 kV Isolator

FOR

VARIOUS 33/11 kV SUBSTATIONS

IN

MAHARASHTRA

I N D E X

CLAUSE NO.	CONTENTS
1.	Scope
2.	Service Conditions
3.	Standards
4.	Principal Technical Parameters
5.	General Technical Requirements
6.	Tests
7.	Inspection
8.	Quality Assurance Plan
9.	Performance Guarantee
10.	Documentation
11.	Spares
12.	Packing and Forwarding
13.	Qualifying Requirement
14.	Schedules
15	Information to be furnished by the tenderer
Annexure I	List of Standards
Annexure II	Principal Technical Parameters
Annexure III	List of special tests to be conducted
Schedule B	Guaranteed Technical Particulars
Schedule C	Deviations from specifications
Schedule D	Tenderer's experience
Schedule E	Deviations from specified standards
Schedule F	Deviations from test requirements specified in relevant standards
Annexure IV	General arrangement of Isolators

TECHNICAL SPECIFICATION FOR 36KV
AIR BREAK DISCONNECTS (ISOLATORS)

SPEC. NO. STORES:MSC-II/33kV Isolator/2011

1.0 SCOPE:

1.1. This specification covers design, manufacture, testing at manufacturer's works, inspection, packing and delivery of the 36kV outdoor type air break disconnects(isolators) with accessories and auxiliary equipment for installation in various substations in Maharashtra state (India).

1.2. It is not the intent to specify completely herein all details of the design and construction of equipment. However, the equipment shall conform in all respects to high standards of engineering mentioned in clause No. 3.0, design and workmanship and shall be capable of performing in continuous commercial operation upto the supplier's guarantee in a manner acceptable to the purchaser, who will interpret the meanings of drawings and specification and shall have the powers to reject any work or material which, in his judgment, is not in accordance therewith.

1.3. The equipment offered shall be complete with all components necessary for its effective and trouble free operation alongwith associated equipment, interlocks, protection schemes etc. Such components shall be deemed to be within the scope of supplier's supply, irrespective of whether those are specifically brought out in this specification and/or the commercial order or not. All similar parts particularly removable ones shall be interchangeable.

2.0 SERVICE CONDITIONS:

2.1. Equipment to be supplied against this specification shall be suitable for satisfactory continuous operation under the following tropical conditions.

2.1.1.	Maximum ambient temperature	(° C)	50
2.1.2.	Minimum ambient temperature	(°C)	3.5
2.1.3.	Relative humidity	(%)	10 to 100
2.1.4.	Maximum annual rainfall	(mm)	1450
2.1.5.	Maximum wind pressure	(Kg/m ²)	150
2.1.6.	Maximum altitude above mean sea level	(Meters)	1000
2.1.7.	Isoceraunic level	(days/year)	50
2.1.8.	Seismic level (Horizontal acceleration)	(g)	0.3
2.1.8.1.	Climate :	Moderately hot and humid tropical climate, conducive to rust and fungus growth.	

3.0 STANDARDS:

- 3.1. Unless otherwise specified elsewhere in this specification, the rating as well as performance and testing of the Disconnect shall conform to the latest revisions of all the relevant standards available at the time of placement of order as listed in Annexure-I. Copies of Indian Standard Specifications can be obtained from Bureau of Indian Standards, Manak Bhawan, Bahadur Shah Zafar Marg, New Delhi-110 002 on payment of applicable charges.
- 3.2. Equipments meeting with the stipulations of equivalent IEC, ANSI, CSA, DIN Standards, which ensure equal or better quality than the standards listed in Annexure-I, shall also be acceptable. In such case the tenderer should submit alongwith his offer, two copies of such standards, in authentic English translation, if the language of the standard is other than English. In case of dispute, the stipulations in the English translation, submitted by the tenderer, shall prevail. Further, in the event of conflict between the stipulations of the standard adopted by the tenderer and the corresponding Indian Standard Specification the latter shall prevail.

4.0 PRINCIPAL TECHNICAL PARAMETERS:

The equipment covered in this specification shall meet the technical requirements listed in Annexure II.

5.0 GENERAL TECHNICAL REQUIREMENTS:

5.1. Type of disconnects:

- 5.1.1. The disconnect shall be three phase gang operated horizontal double break type with rotating type moving blades and with or without gang operated vertical break earth blades.

5.2. Current carrying parts:

- 5.2.1. Material of earthing blades and contacts shall be the same as those of main switch moving blades and contacts respectively. Cross sectional area of earthing blades and contacts shall not be less than 50% of cross sectional area of main blades and contacts. The earthing blades shall have the same short time current rating (thermal and dynamic) as that of main switch.

5.3. Current density:

Current density, to be adopted, for all the parts of isolator and terminal connector shall not exceed the following limits:

- | | | | |
|----|----------------------|-------------|---------------|
| a. | Hollow tube sections | - Copper | - 2.0 A/Sq.mm |
| b. | Flat sections | - Copper | - 1.6 A/Sq.mm |
| c. | Terminal connectors | - Aluminium | - 1.0 A/Sq.mm |

5.4. Insulators:

- 5.4.1. The isolators shall be solid core insulators. Polycone insulators shall not be acceptable.
- 5.4.2. The insulators shall be provided with a completely galvanized steel base design for mounting on the support. The base and mounting arrangement shall be such that

the insulator shall be rigid and self supporting and no guying or cross bracings between phase shall be necessary.

- 5.4.3. The insulator shall be made of homogeneous and vitreous porcelain of high mechanical and dielectric strength. It shall have sufficient mechanical strength to sustain electrical and mechanical loading on account of wind load, short circuit stresses etc. Glazing of the porcelain shall be of uniform brown or dark brown colour with a smooth surface arranged to shed away rainwater. The porcelain shall be free from lamination and other flaws or imperfections that might affect the mechanical or di-electrical quality. It shall be thoroughly vitrified, tough and impervious to moisture. The porcelain and metal parts shall be assembled in such a manner and with such material that any thermal differential expansion between the metal and porcelain through the range of temperature specified in this specification shall not loosen the parts or create undue internal stresses which may affect the mechanical or electrical strength or rigidity. The assembly shall not have excessive concentration of electrical stresses in any section or across leakage surfaces. The cement used shall not give rise to chemical reaction with metal fittings. The insulator shall be suitable for water washing by rain or artificial means in service condition.
- 5.4.4. Cap to be provided on top of the insulator shall be of high grade cast iron/malleable steel casting or Aluminium alloy. It shall be machine faced and hot dip galvanized. The cap shall have four nos. of tapped holes spaced on a pitch circle diameter of 76 mm. to accommodate the terminal clamp for supporting the purchaser's busbars. The holes shall be suitable for bolts with threads having anticorrosive protection. The effective depth of threads shall not be less than the nominal diameter of the bolt.
- 5.4.5. The casting shall be free from blow holes, cracks and such other defects.
- 5.4.6. All the ferrous metal parts shall be hot dip galvanized smoothly as per IS 3638 (as amended upto date), IS 2623 or any other equivalent authoritative standard. The material shall be galvanized only after shop operations upon it have been completed. The metal parts before galvanization should be thoroughly cleaned of any paint, grease, rust, scales or alkalis or any foreign deposits which are likely to come in the way of galvanization process. The metal parts coating shall withstand minimum four one minute dips in copper sulphate solution as per IEC-168.
- 5.4.7. The insulator unit shall be assembled in a suitable jig to ensure correct positioning of the top and bottom metal fittings relative to one another. The faces of the metal fittings shall be parallel and at right angle to the axis of the insulator and corresponding holes in the top and bottom metal fittings shall be in a vertical plane containing the axis of the insulator.
- 5.4.8. It shall be the sole responsibility of the supplier to carry out thorough inspection and quality checks on the insulators at the insulator supplier works, before offering the insulators for purchaser's inspection.
- 5.5. Operating mechanism:
 - a. Manual operating mechanism gang operated through Lever/Hand shall be provided for main switch.

b. Manual operating mechanism gang operated through a lever/hand on the operating shaft shall be provided for earth switch.

5.5.1. The operating mechanism shall provide quick, simple and effective operation. The design shall be such that one man shall be able to operate the isolator without undue effort. The earth switch shall close or open by rotation of lever/hand through 90 degrees. The operating mechanism shall be suitable to hold the main switch or earth switch in closed or opened position to prevent operation by gravity, wind, short circuit, seismic acceleration, vibration, shock, accidental touching etc.

5.5.2. Control cabinet:

5.5.2.1. The control cabinet of each operating mechanism shall be made out of 12 SWG (2.64 mm thick) sheet steel in the form of plate or casting. Control cabinet shall be provided with hinged doors alongwith pad locking arrangement. Sloping rain hood shall be provided to cover all sides. 15 mm thick neoprene or better type of gaskets shall be provided to ensure degree of protection of at least **IP55 as per IS: 2147**. The cabinet shall be suitable for fixing on support structure with adjustment for vertical, horizontal and longitudinal alignment. Details of the arrangement provided for such adjustment as well as for sealing shall be furnished alongwith the tender.

5.5.3. Gland plate and glands:

A removable gland plate with double compression type brass cable glands shall be provided with each operating mechanism for terminating all cables.

5.5.4. Auxiliary switch:

5.5.4.1. Main switch operating mechanism shall be equipped with reliable auxiliary switch (with 4 NO & 4 NC contacts) exclusively for purchaser's interlocking and protection scheme. The purchaser shall use this switch either directly or through contact multiplication relays for various protection schemes.

5.5.4.2. The auxiliary switch and auxiliary circuits shall be capable of carrying a current of atleast 10 Amps continuously.

5.5.4.3. Quick make and break (QMB) type auxiliary switch shall have snap action built in within the switch.

5.5.4.4. The auxiliary switches shall be actuated by a cam or similar arrangement directly mounted on the isolator shaft without any intermediate levers, linkages etc. to ensure fool-proof operation.

5.5.4.5. The auxiliary switch is required for main operating mechanism only.

5.5.5. Terminal block and wiring:

Main switch operating mechanism shall be provided with 1100V grade stud type terminal block. Auxiliary switch shall be wired upto the terminal block. The terminal block shall have at least 20 percent extra terminals. All wiring shall be carried out with 1100V grade PVC (Poly Vinyle Chloride) insulated 2.5 sq.mm copper conductor . Maximum conductor temperature shall be as per IS:3961.

5.5.6. Interlocking:

Mechanical interlocking between main switch and earth switch shall be provided.

5.6. Accessories:

The accessories to be provided on the isolator shall include but not to be limited to the following:

5.6.1. Position Indicator:

A position indicator to show whether the isolator is in ON or OFF position.

5.6.2. Counter Balance Springs:

Counter balance springs, cushions etc. shall be provided to prevent impact at the end of travel both on opening and closing of the isolator. The springs shall be made of durable and non-rusting type alloy.

5.6.3. Name Plates:

The disconnect shall be provided with a name plate. The name plate shall be weather proof and corrosion-proof. It shall be mounted in such a position that it shall be visible in the position of normal service and installation. It shall carry the following information duly punched or engraved on it.

5.6.3.1. Isolators base:

MSEDCL:

Name of manufacturer:

A/T No.:

Type, Designation:

Serial number :

Rated voltage (in KiloVolt):

Rated normal current (in Amp) :

Rated short time current (kArms and duration in sec.):

Rated short time peak current in (kAp) :

Weight:

5.6.3.2. Operating mechanism:

MSEDCL

Name of manufacturer:

A/T No.:

Type, Designation:

Auxiliary contacts quantity and rating

Terminal blocks quantity and rating

5.6.4. Padlocking device:

The isolator and earthing switch shall be provided with padlocking device to permit locking of the isolator and earthing switch in both fully open and fully closed positions.

5.7. Signaling:

5.7.1. Signaling of the close position shall not take place unless the movable contact has set in a position in which the rated normal current, the peak withstand current and the short time withstand current can be carried safely.

5.7.2. Signaling of open position shall not take place unless the movable contact has reached the position such that the clearance between the contacts is at least 80% of the isolating distance.

5.8. Earthing:

5.8.1. Flexible copper connections shall be provided between rotating earth blades and the frame which shall have a cross section of at least 50 sq mm and shall be tinned or suitably treated against corrosion.

5.8.2. The frame of each disconnect and earthing switch shall be provided with two reliable earthing terminals for connection to the purchaser's earthing conductor/flat so also clamping screw suitable for carrying specified short time current. Flexible ground connectors shall be provided for connecting operating handle to the earthing flat. The diameter of clamping screw shall be atleast 12 mm. The connecting point shall be marked with earth symbol.

5.9. Design and construction:

5.9.1. The tenderer shall have experience of minimum five years in the design, manufacture and supply of equipment similar to that offered. Full particulars of design, manufacture, jig, template and quality control devices developed for manufacture of the equipments offered in respect of the following items shall be furnished with drawings and descriptions alongwith the tender.

- i. Contacts, material, current density etc.
- ii. Design of contact pressure
- iii. Contact support and fixing arrangement on insulators.
- iv. Bearings, housing of bearings, bushes etc.
- v. Balancing of heights
- vi. Coupling pipes, joints, connection adjustments
- vii. Base plates
- viii. Down pipe, guides joints
- ix. Brass bushes and bearings at various joints
- x. Operating mechanism, type of gear, auxiliary switch, size and thickness of box, degree of protection, gland plate, plate, gland etc.
- xi. Nuts, bolts and fasteners
- xii. Interlocking devices

Offers without the above information or with incomplete information may be rejected.

5.9.2. All live parts shall be designed to have smooth surfaces without any sharp points, edges and other corona producing surfaces so as to eliminate corona at specified extinction voltage or at 1.1 x rated voltage if extinction voltage is not specified.

5.9.3. Fasteners:

Nuts, bolts and washers of 5/8" and higher size shall be hot dip galvanized. The bolts used on tapped holes of insulator cap shall be galvanized by centrifuge process to avoid excess deposition of zinc on threads. Nuts, bolts and washers of less than 5/8" size shall be of stainless steel when used on live parts and nickel plated brass in other parts.

5.9.4. Contacts:

Contacts shall be made out of hard drawn electrolytic grade copper. Arcing contacts wherever provided shall close first and open last. The contact surface shall be silver plated (10 to 15 microns). Fabrication shall be made with suitable jig to avoid deviations during production. Details of size and shape of contacts, springs, backplate, fixing arrangements, design of contact pressure, life of contacts, limit of temperature rise etc shall be furnished alongwith the tender.

5.9.5. Terminal pad:

It shall be made out of electrolytic copper heavily silver plated (10 to 15 microns). The terminal pad shall be suitable for connection to Long barrel bimetallic Lugs. Dimensions of the terminal pad shall be furnished with the tender.

5.9.6. Mounting of contacts:

Fixed contacts shall be mounted on a block or channel welded to 10 mm thick M.S. plate with holes for fixing on insulators. Slots shall be provided for marginal adjustment of height of contacts. The contacts shall rest on a brass block and with initial tension. Suitable device shall be provided to prevent dashing. Fabrication, welding etc. shall be done in suitable jig to avoid deviations during production.

5.9.7. Moving blades:

Contact surface of moving blades shall be heavily silver plated about 10 to 15 microns thick. The surface shall be wiped during closing and opening operations to remove any film, oxide coating etc. Wiping action shall not cause scouring or abrasion of surfaces.

5.9.8. Bearings:

Rotating insulator shall be mounted on a housing with bearings. The housing shall be made of gravity die cast metal with smooth surfaces and suitably machined for seating the bearings. Two nos of bearings with adequate shaft diameter and distance between the bearings shall be provided to avoid wobbling during operations. The bearings shall be of at least 75 mm internal diameter. The bearings shall be of reputed make and lubricated for life. All other friction locations shall be provided with suitable bearings or stainless or brass bushes. The bearings bushes, joints, springs etc. shall be so designed that no lubrication shall be required during the service. Complete details of bearings bushes, housing, greasing etc. shall be furnished with the tender.

5.9.9. Tandom pipe:

Tandom pipes shall be of at least 25 mm ID and class B. One tandom pipe shall be used for phase coupling of double break isolators. Base plate of insulators for connection of tandom pipe shall be made out of one piece of at least 10 mm thick M.S.plate. Bolt and shackle device shall be used to connect tandom pipe to the base plate. Wherever unavoidable sliding clamps may be used. These clamps shall be made out of at least 10 mm thick M.S.flat with four nos. of nuts and bolts. A grubscrew shall be provided for securing connection on tandom pipes. The tandom pipes shall be suitable to connect the isolator in any position.

5.9.10. Down pipe:

50 mm ID class B pipe shall be provided for operating disconnects. The pipe shall be terminated into a suitable swivel or universal type joint between the insulator bottom bearing and the operating mechanism to take care of marginal angular misalignment at site. All brackets, guides etc. shall be mounted on the base of the isolator. Arrangement of mounting any guide, bracket, part etc. on support structure except the operating mechanism and the base shall not be accepted.

5.9.11. Base:

Each phase of isolator shall be provided with a rigid base fabricated from steel sections. The base shall be suitable for mounting on support structures. Fabrication, welding etc shall be done by suitable jig, power press, templates to avoid deviations during production. Details and dimensions of sections, jig, templates and device used for production of the base shall be furnished with the tender.

5.10. Supporting structure:

5.10.1. The tenderer shall quote unit prices for support structure for the isolators offered. These support structures shall be fabricated out of galvanised ERW pipe conforming to IS:1239 or tube fabricated out of M.S. plates.

5.10.2. The support structure shall be suitable for mounting operating mechanism and guides. It shall be designed to withstand short circuit forces, wind pressure, seismic forces etc. along with the operating forces, vibration, shocks etc. at actual site conditions with adequate factor of safety. The tenderer shall furnish detailed design, calculations, etc. for support structures. These details shall also include loading data.

5.10.3. The masonry or concrete in foundations shall be arranged and constructed by the purchaser. The tenderer shall furnish complete data for design of foundations. The foundation bolts for the structures shall be in the scope of supplier of structures. The foundation bolts shall be supplied well in advance for grouting.

5.10.4. The purchaser reserves the right to purchase the support structure with foundation bolts from the tenderer or make his own separate arrangements for any type/quantity of isolators.

5.11. Terminal connectors:

5.11.1. The tenderer shall quote unit rates for the following type of terminal connectors:

It should be made of EC Grade Aluminium alongwith suitable bimetallic plate of minimum 1 mm thickness. It should be crimping type and suitable for 0.2 sq.inch single ACSR conductor.

5.11.2. 6 numbers of the terminal connectors are required per set of Isolator. The purchaser reserves the right to procure terminal connectors from the tenderer in part or full quantity or make his own arrangement for the balance or full quantity.

5.12. Assembly:

The disconnect shall be fully assembled at the works of the tenderer. Typical operations shall be carried out on each type of fully assembled disconnect to ascertain that all parts fit correctly and function satisfactorily.

5.13. Painting, galvanizing and climate proofing:

5.13.1. All interiors and exteriors of enclosures, cabinets and other metal parts shall be thoroughly cleaned to remove all rust, scales, corrosion, grease and other adhering foreign matter and the surfaces treated by recognized phosphating (e.g. seven tank phosphating sequenced). After such preparation of surfaces, two coats of zinc oxide primer shall be given by suitable storing and air drying etc. before final painting. Colour of the final paint shall be of shade no.631 of IS:5 i.e. epoxy light gray. The final painted cubical shall present esthetically pleasing appearance free from any dent or uneven surface.

5.13.2. Paint inside the metallic housing shall be of ant condensation type and the paint on outside surfaces shall be suitable for outdoor installation.

5.13.3. All ferrous parts not suitable for painting such as structural steel, pipes rods, levers, linkages, nuts and bolts used in other than current path etc. shall be hot dip galvanised. Galvanisation shall be done after completion of fabrication which shall be capable to prevent corrosion in view of the severe climatic conditions. Thickness of zinc coating shall not be less than 610 gm of zinc per sq. meter of surface. Zinc coating shall be smooth clean and of uniform thickness and free from defect. Preparation of galvanising and the galvanising itself shall not adversely affect the mechanical properties of the coated material. The quality shall be established by tests as per IS2633. Galvanising of nuts and bolts shall be carried out by centrifugal or suitable process so that the bolts will easily fit into the tapped holes/nuts.

5.13.4. All components shall be given adequate treatment of climate proofing so as to withstand corrosion and severe service conditions.

5.13.5. Complete details of painting, galvanising and climate proofing of the equipments shall be furnished in the tender.

6.0 TESTS:

6.1. Type Tests:

6.1.1. The equipment offered, shall be fully type tested as per the relevant standards. The tenderer shall furnish one set of the type test reports alongwith the offer. The purchaser reserves the right to demand repetition of some or all the type tests in the

presence of purchaser's representative. For this purpose the tenderer may quote unit rates for carrying out each type test.

6.1.2. If type tests are carried out beyond 5 years, then the offer may be considered for placement of order however, successful bidders have to carry out the said type tests before commencement of the supply at their own expense.

6.1.3. During the type test the disconnect shall be mounted on its own support structure or equivalent support structure and installed with its own operating mechanism to make the type tests representative. Drawing of equivalent support structure if any and mounting arrangements made for type tests shall be furnished for purchaser's approval before conducting the type tests.

6.1.4. The type tests shall be conducted on the disconnect alongwith approved insulators and terminal connectors.

6.1.5. Mechanical endurance test shall be conducted on the main switch as well as earth switch on one disconnect of each type.

6.1.6. Successful tenderer shall submit all type test reports of offered design of isolator as per relevant IS /IEC standards to office of the Chief Engineer (Stores) and get approved it before commencement of the supply. The original type test reports should be made available for verification.

6.2. Acceptance and Routine Tests:

6.2.1. All acceptance and routine tests as stipulated in the relevant standards shall be carried out by the supplier in presence of purchaser's representative.

6.2.2. Mechanical operation test (routine test) shall be conducted on the complete disconnect (Main switch and Earthswitch) at supplier's works and a certified test report be furnished to the purchaser. Alternatively the tenderer may offer to conduct this test at purchaser's substation in which case the purchaser shall make necessary arrangement to erect the disconnect at his substation site under supervision of tenderer's representatives (if necessary) in case this test is offered to be conducted at site. Expenses of the tenderer's representatives for supervision shall not be borne by the purchaser.

6.2.3. The test report of power frequency voltage withstand test conducted on the insulator shall be furnished for purchaser's acceptance in lieu of conducting the power frequency(dry) test on main circuit(routine test).

6.3. Immediately after finalisation of the programme of type/acceptance/routine testing, the supplier shall give three weeks' advance intimation to the purchaser, to enable him to depute his representative for witnessing the tests.

6.4. Special Tests:

Special tests listed in Annexure III shall be carried out in presence of purchaser's representative.

6.5. Test certificates and documents of the following items shall be furnished at the time of routine tests.

a. Chemical analysis of copper alongwith a copy of central excise certificate/gatepass indicating genuine source of procurement of electrolytic grade copper

- b. Bearings
- c. Fasteners
- d. Universal/swivel joint coupling
- e. Insulators
- f. Auxiliary switch
- g. Interlocking devices
- h. Terminal block

The purchaser may at his discretion request additional test certificates for other items as reasonably required to substantiate the quality of the same.

7.0 INSPECTION:

The inspection may be carried out by the purchaser at any stage of manufacture. The successful Tenderer shall grant free access to the purchaser's representative at a reasonable time when the work is in progress. Inspection and acceptance of any equipment under this specification by the purchaser, shall not relieve the supplier of his obligation of furnishing equipment in accordance with the specification and shall not prevent subsequent rejection if the equipment is found to be defective. The supplier shall keep the purchaser informed in advance, about the manufacturing programme so that arrangement can be made for inspection.

The purchaser reserves the right to insist for witnessing the acceptance/routine testing of the bought out items.

8.0 QUALITY ASSURANCE PLAN:

8.1. The tenderer shall invariably furnish following information alongwith his offer, failing which his offer shall be liable for rejection. Information shall be separately given for individual type of the disconnect.

- i. Statement giving list of important raw materials, including but not limited to :
 - a. Copper
 - b. Steel
 - c. Springs
 - d. Bearings
 - e. Nuts & Bolts
 - f. Operating mechanism and its components such as aux. switch, terminal block, etc.
- ii. Names of sub suppliers for the raw materials, list of standards according to which the raw materials are tested, list of tests normally carried out on raw materials in presence of tenderer's representative, copies of test certificates etc.
- iii. Information and copies of test certificates as in (i) above in respect of bought out accessories.

- iv. List of manufacturing facilities available.
- v. Level of automation achieved and list of areas where manual processing still exists.
- vi. List of areas in manufacturing process, where stage in inspections are normally carried out for quality control and details of such tests and inspections.
- vii. Special features provided in the equipment to make it maintenance free.
- viii. List of testing equipments available with the tenderer for final testing of equipment and test plant limitation, if any, vis-a-vis the type, special, acceptance and routine tests specified in the relevant standards. These limitations shall be very clearly brought out in **Schedule-F, i.e. schedule of deviations from specified test requirements.**

8.2. The tenderer shall submit following information alongwith offer.

- i. List of raw materials as well as bought out accessories, and the names of subsuppliers selected from the list furnished alongwith offer.
- ii. Type test certificates of the raw material and bought out accessories.
- iii. Quality Assurance Plan (QAP) with hold points for purchaser's inspection. The quality assurance plan and purchaser's hold points shall be discussed between the purchaser and supplier before the QAP is finalised.

8.3. The successful tenderer shall submit the routine test certificates of bought out accessories at the time of routine testing of the fully assembled disconnect. The Indian bidder shall also submit copies of central excise gate passes for the raw materials.

9.0 PERFORMANCE GUARANTEE:

The equipment shall be guaranteed for satisfactory performance for a period of **66 months** from the date of receipt at site in good condition or **60 months** from the date of commissioning, whichever is earlier. In case of failure within this period the supplier will make good the faulty equipment at no extra cost to the purchaser.

10.0 DOCUMENTATION:

10.1. All drawings shall conform to international standards. All drawings shall be "A3" size only. All dimensions and data shall be in System International units.

10.2. List of drawings and documents:

The tenderer shall furnish four sets of following drawings alongwith his offer:

- a. General outline and assembly drawings of the disconnect, operating mechanism, structure, insulator and terminal connector.
- b. Sectional views and descriptive details of items such as moving blades, contacts, arms, contact, pressure, contact support, bearing, housing of bearings, bushes, balancing of heights, phase coupling pipes, base plate, operating shaft, guides, swivel joint operating mechanism and its components etc.
- c. Drawings with structure for the purpose of type tests.

- d. Name plate.
- e. Schematic drawing
- f. Type test reports in case the equipment has already been type tested.
- g. Test reports, literature, pamphlets of the bought out items, and raw material.

10.3. The successful tenderer shall, within 10 days from date of LOA get approval of above said drawings from office of CE (Stores), MSEDCL, Mumbai.

10.4. Six sets of the type test reports, duly approved by the purchaser, shall be submitted by the supplier for distribution, before commencement of supply. Adequate copies of acceptance and routine test certificates, duly approved by the purchaser, shall accompany the dispatched consignment.

10.5. The manufacturing of the equipments shall be strictly in accordance with the approved drawings and no deviation shall be permitted without the written approval of the purchaser. All manufacturing and fabrication work in connection with the equipment prior to the approval of the drawing shall be at the supplier's risk.

10.6. Approval of drawings/work by purchaser shall not relieve the supplier of his responsibility and liability for ensuring correctness and correct interpretation of the latest revision of applicable standards, rules and codes of practices.

10.7. INSTRUCTION MANUALS:

Twenty five copies of the erection, operation and maintenance manuals in English shall be supplied for each type of the disconnect one month prior to dispatch of the equipment. The manual shall be bound volume and shall contain all drawings and information required for erection, operation and maintenance of the disconnect including but not limited to the following particulars:

- a. Marked erection prints identifying the component parts of the disconnect as shipped with assembly drawings.
- b. Detailed dimensions and description of all auxiliaries.
- c. Detailed views of the insulator stacks, metallics, operating mechanism, structure, interlocks, spare parts etc.

11.0 Spares :

The tenderer shall furnish in his offer, a list of spares with unit rates for disconnect that may be necessary for maintenance of the disconnect for a period of five years. The purchaser reserves the right for selection of items and quantities of these spares to be ordered.

The cost of following spares shall be quoted separately.

- a. Insulators
- b. Contacts
- c. Moving blades
- d. Springs
- e. Bearings

In addition list of optional spares may be enclosed.

12.0 PACKING AND FORWARDING:

- 12.1. The equipment shall be packed in crates suitable for vertical/horizontal transport, as the case may be, and suitable to withstand handling during transport and outdoor storage during transit. The supplier shall be responsible for any damage to the equipment during transit, due to improper and inadequate packing. The easily damageable material shall be carefully packed and marked with the appropriate caution symbols. Wherever necessary, proper arrangement for lifting, such as lifting hooks etc. shall be provided, Any material found short inside the packing cases shall be supplied by supplier without any extra cost.
- 12.2. Each consignment shall be accompanied by a detailed packing list containing the following information.
- a. Name of the consignee
 - b. Details of consignment
 - c. Destination
 - d. Total weight of consignment
 - e. Sign showing upper/lower side of the crate.
 - f. Handling and unpacking instructions
 - g. Bill of material indicating contains of each package.
- 12.3. The supplier shall ensure that the packing list and bill of material are approved by the purchaser before dispatch.

13.0 QUALIFYING REQUIREMENTS: As per Tender .

14.0 SCHEDULES:

- 14.1. The tenderer shall fill in the following schedule which form part of the tender specification and offer. If the schedules are not submitted duly filled in with the offer, the offer shall be liable for rejection.
- Schedule - 'D' - Tenderer's Experience.
- Schedule - 'E' - Deviations from specified standards.
- Schedule - 'F' - Deviations from specified test requirements
- 14.2. Unless otherwise brought out separately by the tenderers in the schedules of deviations (schedules `C', `E' & ``F') the disconnect offered shall be deem to conform to the specification, scrupulously. All deviations from the specification shall be brought out in the schedules of deviation (Schedule 'C'). The discrepancies between the specification and the catalogues or literature submitted as part of the offer shall not be considered as valid deviations unless specifically brought out in the schedules of deviations.
- 14.3. For any deviation from the specification, which is not specifically brought out in the schedule of deviation, the offer may be liable for rejection. The deviations brought

out in the schedule shall be supported by authentic documents, standards and clarifications. Otherwise the offer may be liable for rejection.

- 14.4. The tenderer shall submit the list of orders for similar type of equipments, executed or under execution during the last five years, with full details in the schedule of Tenderer's experience (Schedule 'D') to enable the purchaser to evaluate the tender. In case the equipment are being designed and manufactured in collaboration with other manufacturers the following additional information shall be submitted by the tenderer alongwith his offer.
- i. Copy of the collaboration agreement executed between the tenderer and the collaborator.
 - ii. List of orders for suitable equipments, executed/being executed by the collaborator during the last 8 years.

15.0 INFORMATION TO BE FURNISHED BY THE TENDERER:

A) Following Documents have to be submitted with offer in electronic format

- 15.1. Detailed design, calculations, etc. for support structures.
- 15.2. Complete data for design of foundations
- 15.3. Names of sub suppliers for the raw materials.
- 15.4. List of manufacturing facilities available.
- 15.5. List of testing equipments available with the tenderer
- 15.6. a list of spares with unit rates for disconnect that may be necessary for maintenance of the disconnect for a period of five years.

B) Following Documents have to be submitted physically with offer.

- 15.7. Type test certificates of the raw material and bought out accessories.
- 15.8. General outline and assembly drawings of the disconnect, operating mechanism, structure, insulator and terminal connector.
- 15.9. Sectional views and descriptive details of items such as moving blades, contacts, arms, contact, pressure, contact support, bearing, housing of bearings, bushes, balancing of heights, phase coupling pipes, base plate, operating shaft, guides, swivel joint operating mechanism and its components etc.
- 15.10. Drawings with structure for the purpose of type tests.
- 15.11. Name plate.
- 15.12. Schematic drawing
- 15.13. Type test reports
- 15.14. Documentary evidence to prove not less than 5 years experience in design manufacture & testing at work for 36KV Isolator.
- 15.15. For ready reference of the tenderer, the items of information required to be invariably furnished by the tenderer in his offer, are listed below.

- i. One copy of the authentic English translation of each of the standards to which the offered equipment conforms in case those are other than the standards specified in this specification as per clause no.3.0.
- ii. Details of design and construction, operating mechanism, jig fixture and devices used by the tenderer for quality control etc as per cl.No 5.9.
- iii. Details of painting, galvanising and climate proofing of equipments as per cl.No. 5.13.
- iv. Drawing as per cl. 10.0.
- v. **Schedule B to F as per cl. 14.0.**

15.16. The tenderer shall also arrange to demonstrate various devices, components etc., depute his representatives for discussion/clarifications and/or furnish additional information as required by the purchaser. Failure to furnish such information/clarification/ demonstration may render the offer to be summarily rejected.

ANNEXURE-I
LIST OF STANDARDS
(REF CLAUSE NO.3.1)

Sr.No.	Standard No.	Title
1	IS:1818	Alternating current isolators (disconnectors) and earthing switches
2	IS:9921	-do-
3	IEC:129	-do-
4	IS:2544	Insulators
5	IS 2147	Degree of protection provided by enclosures
6	IS:4691	-do-
7	IS:4722	Rotating Electrical Machines
8	IS:2629	Recommended practice for hot dip galvanising of iron and steel
9	IS:4759	Hop dip galvanization coating on Structural Steel.
10	IS:2633	Method of testing weight thickness and uniformity of coating on fasteners
11	IS:1573	Electro plated coating of zinc on Iron & Steel.
12	IS:3033	Spring Washers
13	IS:2016	Plain washers
14	IE Rules 1956	Indian Electricity Rules
15	IEC:168	Tests on Indoor and Outdoor post Insulator
16	IS:3961	Recommended current rating for PVC Insulated and PVC Sheeted heavy Duty Cables.
17	IS: 5561	Power Connectors
18	IS:1554	PVC Cables
19	IS:5578	Guide for marking of Insulated conductors and arrangement for switchgear bus bar main connectors & Auxiliary wirings.
20	IS:11353	Guide for Uniform system of marking and identification of conductors and apparatus terminals.

ANNEXURE-II
PRINCIPAL TECHNICAL PARAMETERS
(REF.CLAUSE NO.4.0)

Sr.No	Technical parameter	Units	Requirement
1	Rated Freq.	Hz	50
2	System Neutral Earthing		Effectively earthed.
3	No.of phases(Poles)	No.	3
4	Temperature rise	°C	As per relevant IS/IEC
5	Safe duration of overload	Minutes	
	a) 150% of rated current		5 minutes
	b) 120% of rated current		30 minutes
6	Rated voltage	KVrms	36
7	Type of disconnect (AB)		DBCR
8	Rated normal current	Arms	800
9	Rated short time withstand current of MS. and EB for 3 seconds.	KArms	25
10	Rated Peak current of MS and EB	KA peak	62.5
11	Rated short circuit making current of E.B.	KA peak	62.5
13	Basic insulation level		
	i) Lightning impulse withstand voltage	KVpeak	
	a) To earth and between poles		170
	b) Across isolating distance.		195
	ii) Rated power frequency withstand voltage	kVrms	
	a) To earth and between poles		70
	b) Across isolating distance		80
14	Minimum creepage	mm	900
15	Center to Center spacing for installation	mm	1500
16	Minimum clearances	mm	
	i) Phase to earth		430
	ii)Between the rotating post and fixed post on one phase		485
17	Height of centre line of terminal pad above ground level	mm	3885
12	Special requirements a. Earthing blades shall be capable to discharge the trapped charge of the line. b. Isolator Main switch shall be required to make or break the line charging current when no significant change in voltage occurs across the isolating distance on account of make or break c. The Isolator required is not with turn and twist mechanism, it is rotating type		

NOTES :-

DBCR - DOUBLE BREAK CENTRE POLE ROTATING ISOLATOR

AB - AIR BREAK

MS - MAIN SWITCH

EB - EARTH BLADE

APP - APPROXIMATE

ANNEXURE-III
LIST OF SPECIAL TESTS TO BE CARRIED OUT
(REF.CLNO.6.4)

Sr.No.	Name of the Test	Standard to which it conforms
1	Tests on Insulators	IS : 2544
	-----do-----	IEC : 168
2	Tests on terminal connectors	IS : 5561
3	Tests on Galvanised components	IS : 2623
4	Operation tests on operating mechanism and interlock	
5	Endurance tests on auxiliary switches	

SCHEDULE 'D'

Schedule of Tenderer's Experience

(REF. CL. NO. 13.0)

Tenderer shall furnish here a list of similar orders executed under execution by him during the last five years and the name/s and address/es of person/s to whom a reference may be made by Purchaser in case he considers such a reference necessary.

Sr. No.	Name and description of order	Value of order	Period of supply & commissioning	Name and address of person to whom reference may be made
1	2	3	4	5

Name of the firm_____

Signature of tenderer_____

Designation-----

Date _____

SCHEDULE `E'

Schedule of Deviations from Specified Standards

(REF. CL. NO. 13.0)

Sr. No.	Parameters	Stipulation of specified standards		Stipulation of specified standards specified by tenderer		Remarks
		Standard Reference	Stipulation	Standard Reference	Stipulation	

Name of the firm_____

Signature of tenderer_____

Designation-----

Date _____

SCHEDULE-F

DEVIATIONS FROM TEST REQUIREMENTS SPECIFIED IN RELEVANT STANDARDS

(REF.CL.NO.13.0)

Sr. No.	Name of Test	Standard Ref. No. & Clause No.	Requirements of standard	Proposed deviation	Reasons for deviation
---------	--------------	--------------------------------	--------------------------	--------------------	-----------------------

- 1 Type Tests
- 2 Special Tests
- 3 Acceptance Tests
- 4 Routine Tests

Name of the firm_____

Signature of tenderer_____

Designation-----

Date _____

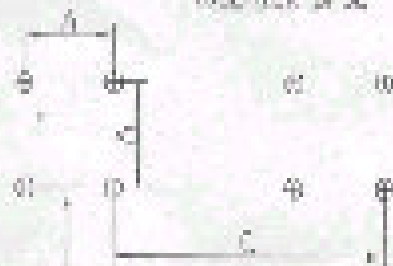
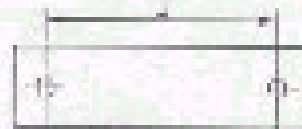
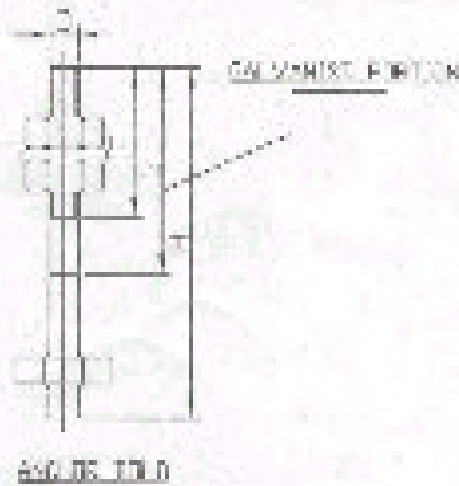

WATER VOLTAGE (KV)	
A	211
B	2000
C	650
D	50
E	50
F	50
G	50
H	400
J	100

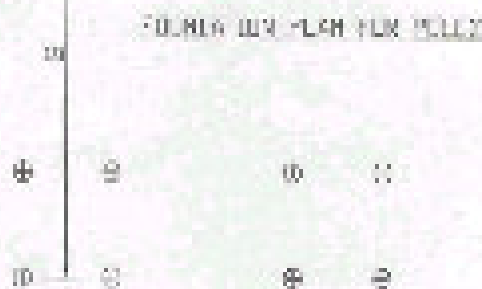

ALL DIMENSIONS ARE IN MM

SCALE : 1:10

GENERAL ARRANGEMENT OF 36KV INSULATOR

MSEDCL

DRAWN

DESIGNED

SUBMITTED

APPROVED

DESIGN

MSEDCL/EST/STAFF

DISTRIBUTION SECT.
(M.F. CELL)

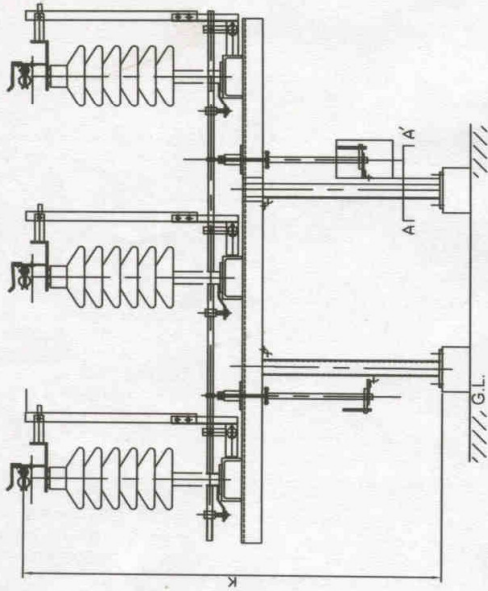

ELEVATION

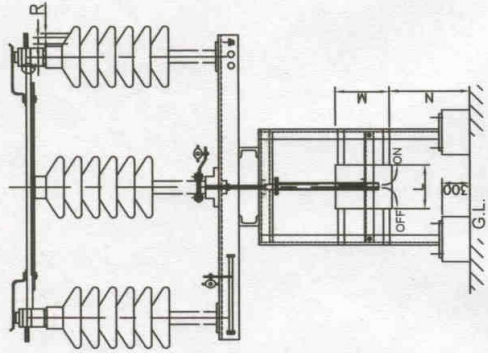

END VIEW

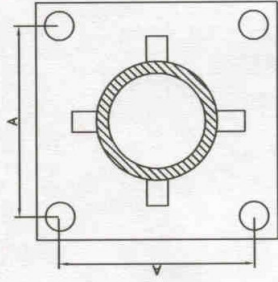

SECTION A A

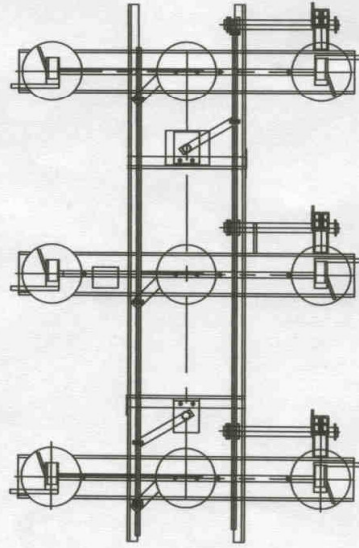

PLAN

DIMENSION TABLE				
A	K	L	M	N
200	3885	500	350	800

ALL DIMENSIONS ARE IN MM

SCALE : NTS

MSEDCL
DISTRIBUTION SECTION
(M.M CELL)

DEPT



WEIGHT(kg)

REF. TO ASSY. DRG.

TITLE
GENERAL ARRANGEMENTS OF
36 KV ISOLATOR

DRG. NO.
MM/36KV/ISO/GA/02

SHEET NO. 1 | REV. 01

DRN.	NAME	SIGN.	DATE
	A K P	(Signature)	31/05/06
	P.R. Hajar	(Signature)	31/05/06
	K.K. Sanyal	(Signature)	31/05/06
	S.H. (Signature)	(Signature)	31/05/06

GUARANTEED TECHNICAL PARTICULARS FOR 36 kV ISOLATORS

Name of manufacturer	Text
Manufacturer's type	Text
The equipment shall be conformed to IS:9921 : Yes/No	Boolean
Type of disconnecter: outdoor type air break disconnects three phase gang operated horizontal double break type with rotating type moving blades : Yes/No	Boolean
Offered Isolator shall be suitable for System frequency 50 HZ $\pm 3\%$: Yes/No	Boolean
Rated voltage of Isolator shall be 36 kV : Yes/No	Boolean
Max. current that can be safely interrupted by the isolator in Amps	Text
Nominal Continuous current rating : min 800 Amp	Text
Rated short time current For 3 seconds : min 25 kArms	Text
Rated peak short time current : min 62.5 kApeak	Text
Current density at the minimum cross section of Moving blade : max. 2 A/sq. mm	Text
Current density at the minimum cross section of Terminal pad : max 1.6 A/sq. mm	Text
Current density at the minimum cross section of Contacts : Max 1.6 A/sq. mm	Text
Current density at the minimum cross section of Terminal connector Max. 1 A/sq. mm	Text
Max. temperature rise of current carrying parts when carrying rated current continuously ($^{\circ}\text{C}$) as limit indicated in the IS : 9921 : Yes/No	Boolean
Derating factor for Normal Site Conditions	Text
Derating factor for heavily polluted area	Text
Derating factor for costal area (i.e. for high humidity)	Text
Phase to Earth Dry impulse withstand voltage : (min 170 kVpeak)	Text
Isolating distance Dry impulse withstand voltage : (min 195 kVpeak)	Text
Phase to Earth Wet power frequency withstand voltage : (min 70 kVrms)	Text
Isolating distance Wet power frequency withstand voltage : (min 80 kVrms)	Text
Minimum center to center clearance Between two poles shall be 1500 mm	Text
Minimum clearance in air Between Phase and earth i.e Bird clearance : (min 430 mm)	Text

Minimum clearance in air Between rotating post and fixed post on one phase: (min 485 mm)	Text
No.of insulators per pole shall be 3 nos. : Yes/No	Boolean
No. of breaks per pole shall be Two : Yes/No	Boolean
Type of closing/opening mechanism shall be gang operated through Hand : Yes/No	Boolean
Material and grade of Contacts shall be hard drawn electrolytic grade copper :	Text
Cross sectional area of fixed Contacts : min 500 sq. mm.	Text
No. of operations the isolator can make without deterioration of contacts.	Text
Thickness of silver plating provided on the contact surface. (10 to 15 microns)	Text
Material and grade of Moving blades shall be hard drawn electrolytic grade copper	Text
Cross sectional area of Moving blades : Min 400 sq. mm for hollow tube and 500 for solid plate.	Text
Thickness of silver plating provided on Contact surface of moving blades. (10 to 15 microns).	Text
Material of contact support shall be galvanized M. S. : Yes/No	Boolean
Size of contact support i.e. either channel or block	Text
Material of plate on which a block or channel welded shall be galvanized M.S.	Text
Size of plate on which a block or channel welded : Min 10 mm	Text
Thick steel sheet shall be used for rain hood : Yes/No	Boolean
Thickness of steel sheet used for Rain hood : min 12 SWG i.e. 2.64 mm	Text
Material of 5/8" and higher size Nuts and Bolts used in live part shall be hot dip galvanized.	Text
Material of less than 5/8" size Nuts and Bolts used in live part shall be of stainless steel	Text
Size of Nuts and Bolts used in live part	Text
Material of 5/8" and higher size Nuts and Bolts used in other part shall be hot dip galvanized.	Text
Material of less than 5/8" size Nuts and Bolts used in other part shall be of nickel plated brass	Text
Size of Nuts and Bolts used in other part	Text

Material of Insulator base plate below fixed insulator shall be M.S.	Text
Size of Insulator base plate below fixed insulator	Text
Thickness of Insulator base plate below fixed insulator : min 10 mm.	Text
Material and size of stud and bolts used for fixing of Insulator on base plate	Text
Material of Insulator base plate below rotating insulator	Text
Size of Insulator base plate below rotating insulator	Text
Thickness of Insulator base plate below rotating insulator : min 10 mm.	Text
Material of Bearing housing	Text
Size of Bearing housing (atleast 75 mm inner dia)	Text
Method of casting of Bearing housing shall be gravity die cast : Yes/No	Boolean
No. of bearings min 2 Nos	Text
Location of bearings	Text
Size of bearings	Text
No. of bushes	Text
joints of bushes	Text
location of bushes	Text
Bushes shall be made of Brass	Text
Size of bushes	Text
Size of Tandem pipe (at least 25 mm ID)	Text
Length of Tandem pipe (in mm)	Text
Class of Tandem pipe shall be class B	Text
Single Tandem pipe shall be used	Text
Size of shackle and screw to fix the tandem pipe	Text
No of clamps (in nos.)	Text
Clamps shall be made of M. S. Flat	Text

Thickness of clamps shall be min 10 mm	Text
Type of interlock (Mechanical interlock)	Text
Size of Down pipe (50 mm ID)	Text
Length of Down pipe in mm	Text
Class of Down pipe (Class B)	Text
Type of joint between bearing and down pipe (swivel type)	Text
Type of joint between down pipe and operating mechanism (universal/swivel type)	Text
Material of Control Cabinet shall be Sheet Steel	Text
Thickness of Control Cabinet shall be min. 12 SWG i.e.2.64 mm thick sheet steel	Text
Degree of protection of Control Cabinet (at least IP55 as per IS 13947)	Text
Type of cable gland of Control Cabinet (double compression type brass cable glands)	Text
Size of cable gland of Control Cabinet	Text
No. of cable gland of Control Cabinet	Text
Removable gland plate shall be provided for Control Cabinet : Yes/No	Boolean
Make of Insulated Wires	Text
Type of Insulated Wires (2.5 sq. mm PVC insulated copper wire)	Text
Rating of Insulated Wires (1100 V grade)	Text
Quantity of Insulated Wires	Text
Type of Insulators (Solid core insulators)	Text
No. of units per insulator	Text
Height of each insulator stack (in mm)	Text
No. of holes of Insulators (4 nos of Tapped holes)	Text
Pitch circle diameter of Insulator(76 mm)	Text
Tensile strength of Insulator in kg	Text
Compressive strength of Insulator in kg	Text

Torsion strength of Insulator in kg cm	Text
Cantilever strength upright of Insulators in kg	Text
Rated Voltage of Insulators (36 kVrms)	Text
Dry – 1 min Power frequency withstand test voltage of Insulators shall be 75 kV rms : Yes/No	Boolean
Wet – 1 min Power frequency withstand test voltage of Insulators shall be 75 kV rms : Yes/No	Boolean
Impulse withstand voltage of Insulators shall be 170 kVp : Yes/No	Boolean
Power frequency puncture voltage of Insulators in kVrms	Text
Visual discharge voltage level of Insulators shall be 27 kVrms	Text
Creepage distance of Insulators shall be min 900 mm	Text
Size of steel sections used for Base structure	Text
Size of steel sections used for supporting structure	Text
Overall size of Base and supporting structure	Text
Total weight of Base and supporting structure	Text
Materials of braids (Flexible tinned copper)	Text
Cross section of braids shall be at least 50 sq. mm	Text